

ZETEC
THE INSPECTION ADVANTAGE

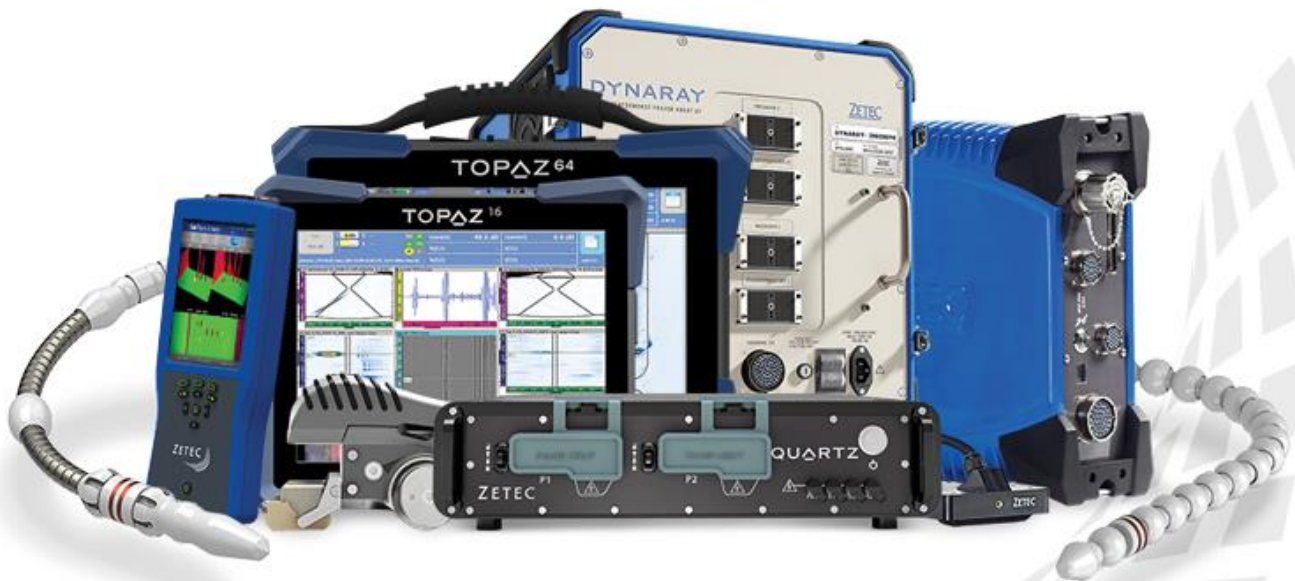

2019 PRODUCT CATALOG

INNOVATION THAT DELIVERS
RESULTS



© 2019 Zetec Inc. All rights reserved.
All the information herein is subject to change without prior notification.

www.zetec.com

Table of Contents

- Introduction to Zetec..... 3
- Industries We Serve..... 5
- Complete Solutions by Industry 6
- Links for More Information 7
- Ultrasound Product Portfolio 8
- Eddy Current Product Portfolio 76

Introduction to Zetec

Zetec is a global leader in nondestructive testing (NDT) solutions for the critical inspection needs of industries the world counts on every day— including power generation, oil and gas, transportation, heavy industry and manufacturing. We serve as a single source for high-performance solutions in both eddy current and ultrasonic technologies.

For over 50 years, we've advanced NDT standards and science, providing new insight and control through inspection solutions that protect our customers' most important assets and ensure the quality of their products.

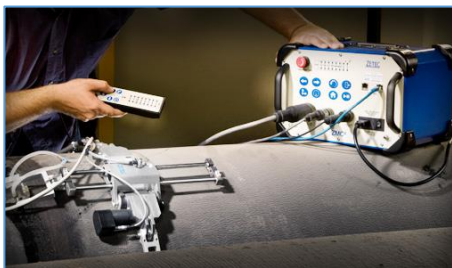

By integrating design and engineering with our own manufacturing, Zetec delivers solutions that optimize productivity, safety and total cost of ownership.

Zetec is a subsidiary of Roper Technologies, Inc., with global engineering and manufacturing centers in Quebec City and at our corporate



headquarters in Snoqualmie, Washington. Zetec support spans the globe, with Centers of Excellence in Houston, Paris, Seoul, Shanghai and Tokyo.

For more information about Zetec®

visit: www.zetec.com and follow us on [LinkedIn](#).

Industries We Serve



Power Generation

Zetec is the choice leading power generation companies make to reduce overall inspection costs, improve safety margins and minimize downtime



Oil & Gas

Zetec is instrumental in helping oil and gas companies conduct fast, complete NDT inspections that save time and avoid unwanted surprises. Zetec delivers well-engineered and field-tested solutions that meet the requirements necessary to solve the challenges oil & gas companies face everyday



Transportation

Zetec understands the key to success for the transportation industry is the assurance that assets are available, operational, safe and reliable. Our range of innovative solutions are designed to meet the requirements of the aerospace, automotive and railway segments



Heavy Industry & Manufacturing

Zetec solutions improve safety, productivity and uptime throughout the manufacturing process meanwhile ensuring high-quality end products. Our extensive line of eddy current and ultrasound solutions gives us tremendous ability to meet the most demanding environments

Complete Solutions by Industry

TECHNOLOGY	CATEGORY	PRODUCT	HEAVY INDUSTRY & MANUFACTURING	POWER GENERATION	OIL & GAS	TRANSPORTATION
Eddy Current	Instruments	MIZ-200	●	●	●	●
		MIZ-80iD	●	●		
		MIZ-85jD	●	●		
		MIZ-28		●	●	
		MIZ-21C/21B	●			●
		INSITE	●			●
	Software	●	●	●	●	
Probes	●	●	●	●		
Ultrasound	Instruments	Topaz	●	●	●	●
		DYNARAY & Lite	●	●	●	●
		QuartZ	●	●	●	●
		Zircon	●	●	●	●
		Z-Scan UT	●	●	●	●
	Software	●	●	●	●	
Probes & Wedges	●	●	●	●		
Mechanical Systems	Scanners	NDT Paintbrush	●	●	●	●
		WELD Crawler	●	●	●	
		Motor Controllers	●	●	●	
		MPS Series		●	●	
	Probe Delivery	ZR-100	●	●		
		10D Pusher	●	●		
HS3D Pusher		●	●			

Links for More Information

Company Information	www.zetec.com/about-zetec
Contact Us	www.zetec.com/contact-us
Customer Service	www.zetec.com/customer-support/customer-service
News and Events	http://www.zetec.com/news-events
Pricing	www.zetec.com/customer-support/customer-service
Products	www.zetec.com/products
Product Training	http://www.zetec.com/services/training/product-training
Probe Order Worksheet	www.zetec.com/customer-support/customer-service
Standardized probes	www.zetec.com/customer-support/customer-service
Instrument to Probe Adapters	www.zetec.com/customer-support/customer-service
Quality	http://www.zetec.com/contact-us/quality-compliance
Return Policy	www.zetec.com/customer-support/customer-service
Technical Support	www.zetec.com/customer-support/customer-service
Warranty	www.zetec.com/customer-support/customer-service

Ultrasound Product Portfolio

Ultrasonic Instruments	9
UltraVision Software.....	42
Ultrasonic Scanners	49
Probes & Wedges	61

Ultrasonic Instruments

TOPAZ¹⁶



Characteristics

TOPAZ16 can handle all steps in an inspection process:

- **Preparation:** Specimen editor and focal law calculator for easy setup
- **Acquisition:** Intuitive and highly efficient data acquisition process
- **Analysis:** Full suite of basic and advanced analysis tools onboard
- **Reporting:** Ready to print standard or custom reports in a touch

Compact and lightweight in a robust aluminum casing with no air intake. The full metallic housing improves robustness, thermal transfer efficiency and weighs only 4.5 kg (10 lb).

Dedicated UT Channel: One separated conventional UT channel offers 200V (at 50Ω) pulser and works in P/E or P/C configurations for TOFD examinations and allows combining PA and UT probes on the same inspection configuration.

Two batteries with Hot Swap Battery Capability: Designed to accommodate two batteries in a hot swappable sequential discharge configuration.

Fast and Safe Data Transfer: TOPAZ¹⁶ features an internal solid state drive (SSD) for quick, reliable data transfer and storage during operation.

16-bit amplitude resolution: Signals can be digitized using an 800% FSH scale reducing the chances of re-scan due to signal saturation during the acquisition.

Seamless integration with Zetec Probes and Scanners: Connect any Zetec scanner or probe to TOPAZ¹⁶, and it will automatically recognize and preconfigure accordingly. Probes can be tracked throughout the inspection process, ensuring data integrity and traceability. Also works with other scanners and probes.

Flexible scanning configurations: sector, linear and compound.

Connectivity Options:

- 1 USB 3.0 (10x faster than 2.0), 2 USB 2.0 and gigabyte LAN, HDMI
- UT channel: 1 high-quality UT channels for conventional UT (pulse echo, pitch-and-catch or TOFD)
- Quality PA UT connector with a solid probe latch

Specifications

Feature	TOPAZ 16
Size (H x W x D)	221 x 271 x 120mm (8.7 x 10.6 x 4.7 in)
Weight	4.54 kg (10.0lb) *
Multi-Touch Display	10.4 in. - 1024 x 728 pixels
Air Intake	No
Battery Operation	Yes
Phased Array Connector	ZPAC connector (custom ZIF with latch)
Phased Array Channels	16/64 or 16/128
UT Channels	1 P/E or 1 P/C
Digitizing Frequency	up to 100 MHz
Amplitude Resolution	16 bits
Measurement Gates	4 gates + 1 synchronization gate
Data Interfaces	Ethernet 1000 Base-T 1 x USB 3.0 2 x USB 2.0
Maximum PRF	12 kHz
Max. Pulser Voltage (Open Circuit)	105V PA UT / 215V UT
Max. Applied Voltage (50 ohms)	75V PA UT / 200V UT
Bandwidth (-3 dB)	from 0.5 to 18 MHz
Rectification	Digital
Filtering	Analog/digital (FIR)
Smoothing (Video Filter)	Digital
Self-Check	Yes
Automated Probe Detection	Yes (with Zetec probe ID chip)
Automated Scanner Detection	Yes (with Zetec probe ID chip)
# Focal Laws	256
Maximum Number of Samples	8,192
Maximum Data File Size	700 MB for 16/128 version 300 MB for 16/64 version
Encoder Interfaces	2 quadrature-type
Onboard software	UltraVision Touch™ embedded
Serves as Protection Key	License for UltraVision Touch™
Data Acquisition & Analysis	UltraVision Touch™ UltraVision® 3
Embedded Hard Drive	128 GB SSD
Video Output	HDMI

Feature	TOPAZ¹⁶
Instrument Calibration	Compliant with ISO 18563-1 / EN 12668-1
*Using one battery	

Ordering information

Part Number	Short Description	Description
10053724	ZPA-IUT-TOPAZ-16/64P-KIT	Fully integrated portable Phased Array system featuring up to 16 active channels on up to 64 element probes. Phased Array probes are connected on a solid Zero Insertion Force secured connector whereas 2 Lemo 00 connectors can be used for pulse echo or TOFD inspections. Kit includes 2 batteries, 1 carrying case, 1 power cable NA, 1 power cable Europe, 1 Ethernet cable, 1 AC adapter & 1 USB Flash drive.
10053725	ZPA-IUT-TOPAZ-16/128P-KIT	Fully integrated portable Phased Array system featuring up to 16 active channels on up to 128 element probes for enhanced inspection capabilities. Phased Array probes are connected on a solid Zero Insertion Force secured connector whereas 2 Lemo 00 connectors can be used simultaneously for pulse echo or TOFD inspections. Kit includes 2 batteries, 1 carrying case, 1 power cable NA, 1 power cable Europe, 1 Ethernet cable, 1 AC adapter & 1 USB Flash drive.
10053783	ZPA-IUT-TOPAZ16-16/64P-UPG to 16/128P	TOPAZ16 upgrade from 16/64P to 16/128P configuration. This upgrade does not require any hardware modification.

Note: Details about TOPAZ¹⁶ accessories are presented in [Accessories for TOPAZ³², TOPAZ¹⁶, ZIRCON and QUARTZ](#) section.

TOPAZ³²



Characteristics

Onboard focal law calculator: The advanced calculator enables inspections on complex specimens like axial or circumferential welds, including different weld profiles. It also supports 2D matrix array probes without any additional external software.

High performance in acquisition: TOPAZ³²'s 2-GB data file size improves the efficiency of the inspection of large components. Up to 1024 focal laws allow the creation of as many inspection groups as needed.

Onboard processing performance: Multiple data files can be merged together using the "File Merger" tool. C-Scan data from different files can be consolidated with the "Data Stitching" tool.

Phased Array and Conventional UT combined: TOPAZ³² features a 32:128PR Phased Array section. Two separated conventional UT channels offers 200V (at 50Ω) pulser and works in P/E or P/C configurations for TOFD examinations and allow combining PA and UT probes on the same inspection configuration.

16-bit amplitude resolution: Signals can be digitized using an 800% FSH scale reducing the chances of re-scan due to signal saturation during the acquisition.

Improved data acquisition speed: 64-bit computing power combined with an onboard SSD (solid-state drive) allow users to perform challenging inspections with large data files without compromising acquisition speed.

Fast analysis: TOPAZ³² capability allows for 2 times faster data processing and analysis compared with previous versions. Regardless of size, data files can be stored for quick access, reducing processing time.

UltraVision® touch software embedded: The embedded advanced focal law calculator with visual feedback allows for easy setup preparation. Onboard volumetric merge and measurement tools enable powerful data analysis and inspection report generation. Leverage one single software platform across the entire family of UT products.

2D matrix arrays: UltraVision Calculator supports 2D matrix array probes without using any external software. Unlock the power of matrix array probes with TOPAZ³² tools.

Compound scanning: Sectorial and linear scanning combine to increase the covered inspection area while reducing scanning time.

Seamless integration with Zetec Probes and Scanners: Connect any Zetec scanner or probe to TOPAZ³², and it will automatically recognize and preconfigure accordingly. Probes can be tracked throughout the inspection process, ensuring data integrity and traceability. Also works with other scanners and probes.

Specifications

Feature	TOPAZ ³²
Size (H × W × D)	132 × 260 × 326 mm 5.2 × 10.3 × 12.8 in
Weight*	6.3 kg 13.9 lb
Multi-Touch Display	10.4 in - 1024 x 728 pixels
Air Intake	No
Battery Operation	Yes
Phased Array Connector	ZPAC connector (custom ZIF with latch)
Phased Array Channels	32/128 P or 32/128 PR
UT Channels	2 P/E or 2 P&C
Digitizing Frequency	up to 100 MHz
Amplitude Resolution	16 bits
Measurement Gates	4 gates + 1 synchronization gate
Data Interfaces	Ethernet 1000 Base-T 1 x USB 2.0 3 x USB 2.0
Maximum PRF	12 kHz
Global Data Throughput	up to 10 MB/sec
Max. Pulsar Voltage (Open Circuit)	105V PA UT / 215V UT
Max. Applied Voltage (50 ohms)	75V PA UT / 200V UT
Bandwidth (-3 dB)	from 0.5 to 18 MHz
Real-time Data Compression	Yes
Rectification	Digital
Filtering	Analog/digital (FIR)
Smoothing (Video Filter)	Digital
Self-Check	Yes
Automated Probe Detection	Yes
Dynamic Depth Focusing (DDF)	Yes
Parallel Firing	No
# Focal Laws	1024
Maximum Number of Samples	8,192 (onboard) 16,384 (remote - UltraVision [®] 3)
Maximum Data File Size	2 GB onboard 20 GB (remote using UltraVision [®] 3)
Encoder Interfaces	2 quadrature-type
PC Software Control	UltraVision Touch™ embedded

Feature	TOPAZ ³²
Serves as Protection Key	License for UltraVision Touch™
Data Acquisition & Analysis	UltraVision Touch™ UltraVision® 3
Embedded Hard Drive	120 GB SSD
Video Output	DVI (digital and analog)
Instrument Calibration	Compliant with ISO 18563-1 / EN 12668-1
* 1 battery only	

Ordering information

Part Number	Short Description	Description
10053131	ZPA-IUT-TOPAZ-32/128PR-x64-KIT	Fully integrated portable Phased Array system featuring 64-bit onboard computer and up to 32 active channels on up to 128 elements probe. This instrument can also either use the same 32 transmitters and receivers or can be operated in PR mode using up to 32 channels as transmitters and 32 other receivers for advanced inspections. Phased Array probes are connected on a solid Zero Insertion Force secured connector whereas 4 Lemo 00 connectors can be used simultaneously for pulse echo or TOFD inspections. Kit includes 2 batteries, 1 carrying case, 1 power cable NA, 1 power cable Europe, 1 Ethernet cable, 1 AC adapter & 1 USB Flash drive.
10053132	ZPA-IUT-TOPAZ-32/128P-x64-KIT	Fully integrated portable Phased Array system featuring 64-bit onboard computer and up to 32 active channels on up to 128 elements probe. Phased Array probes are connected on a solid Zero Insertion Force secured connector whereas 4 Lemo 00 connectors can be used simultaneously for pulse echo or TOFD inspections. Kit includes 2 batteries, 1 carrying case, 1 power cable NA, 1 power cable Europe, 1 Ethernet cable, 1 AC adapter & 1 USB Flash drive.

Note: Details about TOPAZ³² accessories are presented in [Accessories for TOPAZ³², TOPAZ¹⁶, ZIRCON and QUARTZ](#) section.



TOPAZ[®]64

Fully Integrated, Portable 64 Channel Phased Array UT Device

ULTRA-INTELLIGENT ULTRASOUND

Welcome to Ultra-Intelligent Ultrasound.

Introducing TOPAZ[®]64, a fully integrated, portable 64 channel Phased Array UT instrument delivering faster, more accurate inspections. It combines the power of 64 active channels for Phased Array UT applications, with the industry's most advanced FULL MATRIX CAPTURE (FMC) and TOTAL FOCUSING METHOD (TFM) capabilities. TOPAZ64 can intelligently handle all your challenging UT inspections using the latest technologies including:



- Full Matrix Capture (FMC)
- Real-Time High Resolution Total Focusing Method (TFM)
- 64 Channel Code-Compliant Phased Array Ultrasound (PAUT)
- Time of Flight Diffraction (TOFD)
- Time Reversal Technique (TR) Option

Whether you are inspecting complex composite materials or thick welds, TOPAZ64 delivers better coverage.

Driven by Industrially Proven UltraVision[®] Software.



TOPAZ64 includes UltraVision Touch software onboard. This powerful, yet easy to use software controls the acquisition of Phased Array UT signals, displays real-time images and provides online and offline data analysis. UltraVision offers many advanced features for TOPAZ64 to improve Phased Array UT inspections, including industry leading FMC, real-time high resolution TFM, and post-processed TFM from recorded elementary A-Scan.

Your Inspection Needs Covered, Challenges Met.

The highly flexible TOPAZ64 completes the TOPAZ family of portable integrated Phased Array ultrasonic instruments. From the unmatched value of TOPAZ16 and the redefined performance of TOPAZ32 to the ultra-intelligent TOPAZ64, you'll quickly agree your needs will be covered, challenges met.

Specifications in this document are subject to change

FEATURE	TOPAZ ⁶⁴
Size (H × W × D)	343 × 278 × 158 mm (13.5 × 10.9 × 6.2 in)
Weight (including one battery)	9.1kg (20.0 lb)
Multi-Touch Display	12.1 in. - 1024 x 728 pixels
Air Intake	No
Battery Operation	Yes
Phased Array Connector	ZPAC
Phased Array Channels	64/64P or 64/128PR
UT Channels	2 P/E or 2 P/C
Amplitude Resolution	16-bits
Measurement Gates	4 + 1 synchronization gate (peak, crossing, autocrossing)
Data Interfaces	Ethernet 1000 Base-T 1 x USB 3.0; 3 x USB 2.0
Maximum PRF	≤ 40 kHz
Data Compression	1, 2, 4, 8, 16
Max. Applied Voltage (50 ohms)	150Vpp PA UT (Bipolar) /75V (Unipolar) / 200V UT
Bandwidth (-3 dB)	0.5 to 18 MHz PA 0.5 to 25 MHz UT
Rectification	Digital
Filtering	Analog / Digital (FIR)
Smoothing	Digital
Self-Check	Yes
Automated Probe Detection	Yes (with Zetec probe ID chip)
Automated Scanner Detection	Yes (with Zetec probe ID chip)
# Focal Laws	1024 with unlimited groups
TFM Frame Size	Up to 1M points
TFM Frame Rate	Up to 110 Hz (65k points frame resolution)
Maximum Number of Samples	16,384
Maximum Data File Size	2 GB ** Unlimited for raw A-Scan data
Encoder Interfaces	3 quadrature-type
Onboard Software	UltraVision Touch embedded
Serves as Protection Key	License for UltraVision Touch
Data Acquisition & Analysis (for remote data acquisition or off line postprocessing)	UltraVision Touch UltraVision 3
Embedded Hard Drive	256 GB SSD
Video Output	HDMI
Instrument Calibration	Compliant with ISO 18563-1 / EN 12668-1

General Specifications

Voltage: 100 to 240 VAC

Frequency: 50 or 60 Hz

Maximum Power: 100 VA

Operating Temperature Range: -10°C to 45°C (14°F to 113°F)

Storage Temperature Range: -40°C to 70°C (-40°F to 158°F)

Relative Humidity: 80% non-condensing

CE mark is an attestation of the conformity with all applicable directives and standards of the European Community. The TOPAZ64 is an instrument of class 1 and installation category II.

Specifications included in this document are subject to change.

Ordering Information

10056334 - ZPA-IUT-TOPAZ-64/64P

Fully integrated portable Phased Array system featuring up to 64 active channels on up to 64-element probe. This instrument can either use the same 64 transmitters and receivers or can be operated in PR mode using up to 32 channels as transmitters and 32 others as receivers for advanced inspections.

10056335 - ZPA-IUT-TOPAZ-64/64P-TFM

Fully integrated portable Phased Array system featuring up to 64 active channels on up to 64-element probe. This instrument can either use the same 64 transmitters and receivers or can be operated in PR mode using up to 32 channels as transmitters and 32 others as receivers for advanced inspections; 65K data points onboard, FMC/TFM capability.

10056328 - ZPA-IUT-TOPAZ-64/128PR

Fully integrated portable Phased Array system featuring up to 64 active channels on up to 128-element probe. This instrument can either use the same 64 transmitters and receivers or can be operated in PR mode using up to 64 channels as transmitters and 64 others as receivers for advanced inspections.

10056337 - ZPA-IUT-TOPAZ-64/128PR-TFM HR

Fully integrated portable Phased Array system featuring up to 64 active channels on up to 128-element probe. This instrument can either use the same 64 transmitters and receivers or can be operated in PR mode using up to 64 channels as transmitters and 64 others as receivers for advanced inspections, bipolar pulsers, 1M data points onboard, FMC/TFM capability.

10056338 - ZPA-IUT-TOPAZ-64/128PR-TFM HR-D

Fully integrated portable Phased Array system featuring up to 64 active channels on up to 128-element probe. This instrument can either use the same 64 transmitters and receivers or can be operated in PR mode using up to 64 channels as transmitters and 64 others as receivers for advanced inspections, bipolar pulsers, 1M data points onboard, FMC/TFM and raw A-Scan data saving capability.

Environmental Tests

As per MIL-STD-810G

Cold Storage - 502.5 procedure I

Cold Operation - 502.5 procedure II

Heat Storage - 501.4 procedure I

Heat Operation - 501.4 procedure II

Temperature Shock - 503.5 procedure II

Vibration - 514.6 procedure I

Transit Drop - 516.6 procedure IV

Drop Test - IEC61010-1

Accessories Ordering Information

10056344 - ZPA-ACC-SPLTBOX64-ZPAC-2ZPAC64+4UT

ZPAC SPLITTER for TOPAZ64 with fast easy attachment system including a solid security latch. It can manage ID data from 2 Phased Array probes allowing UltraVision to recognize them. It includes two pairs of Lemo connectors (individually isolated with switches) to convert 2 Phased Array channels into 2 conventional channels.

10056345 - ZPA-ACC-SPLTBOX64-ZPAC-2OMNI64+4UT

Omni type SPLITTER for TOPAZ64 with fast easy attachment system including a solid security latch. The splitter includes two pairs of Lemo connectors (individually isolated with switches) to convert 2 Phased Array channels into 2 conventional channels.

Phased Array probes are connected to a solid Zero Insertion Force secured connector whereas 4 Lemo 00 connectors can be used simultaneously for pulse echo or TOFD inspections.

System purchase includes: TOPAZ64 unit with UltraVision Touch embedded, 2 batteries, 1 carrying case, 1 power cable (North America), 1 power cable (Europe), 1 AC adapter, 1 Ethernet cable, 1 USB Flash drive and user manual.

Time Reversal option can be added to any TOPAZ64 model.



Zetec holds ISO 9001 and ISO/IEC 17025 certifications



Characteristics

Battery operated: The ZIRCON and a laptop make the perfect pair: with up to 8 hours of battery life to get the job done in almost any condition.

Rugged with no air intake: Compact and robust to be successfully deployed in the field, even in contaminated areas.

Phased Array and Conventional UT combined: ZIRCON features a 32:128PR Phased Array section and 2 conventional UT channels for combining PA and UT probes on the same inspection configuration.

16-bit amplitude resolution: Signals can be digitized using an 800% FSH scale reducing the chances of re-scan due to signal saturation during the acquisition. Complete the inspection right the first time.

Superior Signal Quality: State-of-the-art electronics because Zetec is known for high-quality and outstanding SNR.

UltraVision® Controlled: UltraVision 3 allows performing all activities needed in an inspection process within the same package. From designing the probe and modelling the acoustic field to defining the specimen, parts to inspect and scan plan or calibration, inspection, analysis and reporting. All-in-one seamless integrated package.

Time Reversal Support: Time Reversal allows inspecting complex geometry changing surface of composites materials, reducing the complexity of the mechanical scanners.

Seamless integration: Connect any Zetec scanner or probe to ZIRCON, and it will automatically recognize and preconfigure accordingly. Probes can be tracked throughout the inspection process, ensuring data integrity and traceability.

Specifications

Feature	ZIRCON
Size (H × W × D)	110 × 280 × 325 mm 4.3 × 11.4 × 12.8 in
Weight	5.2 kg 11.5 lb.
Air Intake	No
Battery Operation	Yes
Phased Array Connector	ZPAC connector (custom ZIF with latch)
Phased Array Channels	32/128 PR
UT Channels	2 P/E or 2 P&C
Digitizing Frequency	up to 100 MHz
Amplitude Resolution	16 bits
Measurement Gates	4 gates + 1 synchronization gate
Data Interfaces	Ethernet 1000 Base-T
Maximum PRF	12 kHz
Global Data Throughput	up to 10 MB/sec
Max. Pulsar Voltage (Open Circuit)	105V PA UT / 215V UT
Max. Applied Voltage (50 ohms)	75V PA UT / 200V UT
Bandwidth (-3 dB)	from 0.5 to 15 MHz
Real-time Data Compression	Yes
Rectification	Digital
Filtering	Analog/digital (FIR)
Smoothing (Video Filter)	Digital
Self-Check	Yes
Automated Probe Detection	Yes
Dynamic Depth Focusing (DDF)	Yes
Parallel Firing	No
Time Reversal	Yes ⁽¹⁾
# Focal Laws	1024
Maximum Number of Samples	16,384
Maximum Data File Size	20 GB
Encoder Interfaces	2 quadrature-type
PC Software Control	UltraVision Touch™ embedded
Serves as Protection Key	License for UltraVision Touch™
Data Acquisition & Analysis	UltraVision Touch™ UltraVision® 3
Instrument Calibration	Compliant with ISO 18563-1
(1) Requires Time Reversal firmware option included with ZPA-RDT-ZIRCON-32/128PR-TR-KIT (see Ordering Information for details)	

Ordering information

Part Number	Short Description	Description
10036104	ZPA-RDT-ZIRCON-32/128PR-KIT	PA UT system with up to 32 simultaneous active channels and 128 in total. Can use same 32 channels as transmitters and receivers or 32 channels as transmitters and 32 others as receivers. Solid Zero Insertion Force connector with latch and 4 Lemo 00. Kit includes: 2 batteries, 1 battery charger, 1 carrying case, 1 shoulder strap, 1 power cable NA, 1 power cable Europe, 1 Ethernet cable, 1 AC adapter.
10050599	ZPA-RDT-ZIRCON-32/128PR-TR-KIT	PA UT system with up to 32 simultaneous active channels and 128 in total - Can use same 32 channels as transmitters and receivers or 32 channels as transmitters and 32 others as receivers – Including Time Reversal (TR) hardware and firmware option - Solid Zero Insertion Force connector with latch and 4 Lemo 00. Kit includes: 2 batteries, 1 battery charger, 1 carrying case, 1 shoulder strap, 1 power cable NA, 1 power cable Europe, 1 Ethernet cable, 1 AC adapter.

Note: Details about ZIRCON accessories are presented in [Accessories for TOPAZ³², TOPAZ¹⁶, ZIRCON and QUARTZ](#) section.

QUARTZ

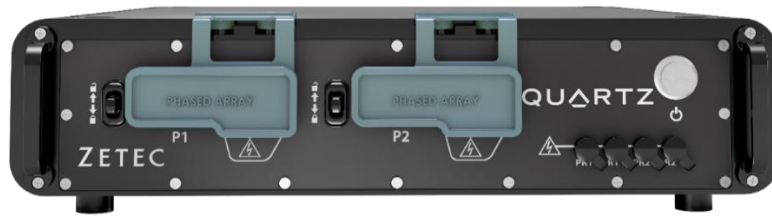

Characteristics

Parallel Firing Capability: Support for 32/128 or 2x16/64 configurations with two simultaneous apertures on one or two probes.

Integrated Probe Splitter: For connecting two phased array probes without any additional accessories.

High Power Phased Array Channels: Quartz incorporates real 100V pulser for the phased array channels. Ideal for the inspection of very thick or difficult-to-penetrate materials.

High Data Throughput: Quartz can deliver up to 30MB/s of data throughput making the difference for demanding applications.

Scalable: Up to 10 Quartz units in parallel controlled by the same UltraVision – almost no inspection configuration is too big.

Automatic Probe Detection: When using Zetec probes, Quartz automatically detects the probes connected ensuring the use of the right probe and simplifying traceability up the reporting process.

Made Tough for Tough Environments: Quartz can be installed close to the probes, reducing cable length. No air conditioning is needed, saving on project complexity and installation costs.

Time Reversal Support: Time Reversal allows inspecting complex geometry changing surface of composites materials, reducing the complexity of the mechanical scanners.

UltraVision® Controlled: UltraVision 3 allows performing all activities needed in an inspection process within the same package. From designing the probe and modelling the acoustic field to defining the specimen, parts to inspect and scan plan or calibration, inspection, analysis and reporting. All-in-one seamless integrated package.

Specifications

Feature	QUARTZ
Size (H × W × D)	420 × 490 × 90 mm 16.5 × 19.3 × 3.5 in
Weight	8.34 kg 18.4 lb
Air Intake	No
Battery Operation	No
Phased Array Connector	2 x ZPAC connector (custom ZIF with latch)
Phased Array Channels	32/128 PR
UT Channels	2 P/E or 2 P&C
Digitizing Frequency	up to 100 MHz
Amplitude Resolution	16 bits
Measurement Gates	4 gates + 1 synchronization gate
Data Interfaces	Ethernet 1000 Base-T
Maximum PRF	20 kHz
Global Data Throughput	up to 30 MB/sec
Max. Applied Voltage (50 ohms)	100V PA UT 200V UT
Bandwidth (-3 dB)	from 0.5 to 18 MHz
Real-time Data Compression	Yes
Rectification	Digital
Filtering	Analog/digital (FIR)
Smoothing (Video Filter)	Digital
Self-Check	Yes
Automated Probe Detection	Yes
Dynamic Depth Focusing (DDF)	Yes
Parallel Firing	Yes
Time Reversal	Yes *
# Focal Laws	1024
Maximum Number of Samples	16,384
Maximum Data File Size	20 GB
Encoder Interfaces	2 quadrature-type or clock directional
PC Software Control	Yes
Serves as Protection Key	License for UltraVision 3™ Basic
Data Acquisition & Analysis	UltraVision Touch™ UltraVision® 3
Instrument Calibration	Compliant with ISO 18563-1
* Requires Time Reversal version. See Ordering Information section for details.	

Ordering information

Part Number	Short Description	Description
10052720	ZPA-RDT-QUARTZ-32/128PR-KIT	PA UT system, up to 32 simultaneous active channels and 128 in total - Can use same 32 transmitter and receiver elements or 32 transmitter and 32 other receiver elements, with parallel firing capability up to two times 16 transmitting and 16 receiving elements – 2 Zero Insertion Force connectors with latch for dual probe connection + 4 Lemo 00. Kit includes: 1 power cable NA, 1 power cable Europe, 1 Ethernet cable and 19” rack mount adaptor plates.
10052721	ZPA-RDT-QUARTZ-32/128PR-TR-KIT	PA UT system, up to 32 simultaneous active channels and 128 in total - Can use same 32 transmitters and receivers or 32 transmitter and 32 other receiver elements – Includes Time Reversal (TR) hardware - 2 Zero Insertion Force connectors with latch for dual probe connection + 4 Lemo 00. Kit includes: 1 power cable NA, 1 power cable Europe, 1 Ethernet cable and 19” rack mount adaptor plates.

Note: Details about QUARTZ accessories are presented in [Accessories for TOPAZ³², TOPAZ¹⁶, ZIRCON and QUARTZ](#) section.

Accessories for TOPAZ³², TOPAZ¹⁶, ZIRCON and QUARTZ

Generic Accessories

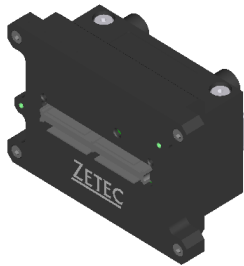

10037251 (ZPA-ACC-ADPBOX-ZPAC-OMNI)

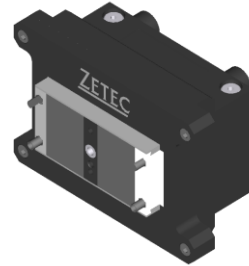

10037252 (ZPA-ACC-SPLTCBL-ZPAC-2HYP64)

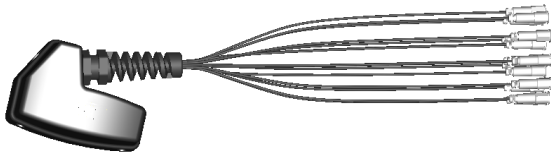

10041164 (ZPA-ACC-SPLTCBL-ZPAC16LEMO-1FT)

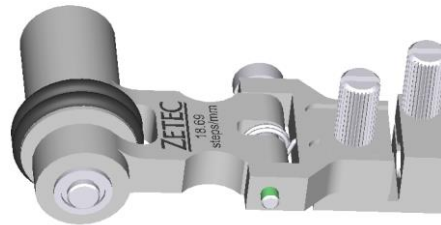

10040557 (ZGN-ACC-ZPAC-ENC-5M-DE15)

Note: Other models of splitters and adaptors could be available on request. Please contact Zetec for more information.

TOPAZ¹⁶ Accessories

Probe Splitter: connect two PA probes at the same time for dual probe weld inspection configurations. The probe splitter is available in two different versions: ZPAC and Omni type probe connectors.

Note: probe splitter is supported by TOPAZ¹⁶ 16/128 only.

Fan Kit: extends the temperature operation range of the unit and allows using it in environments where no other instrument can go.

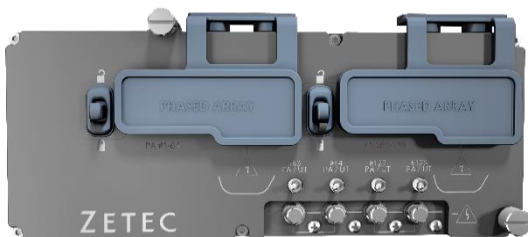

Probe splitter module



Fan kit module

TOPAZ³² Accessories

Probe Splitter: connect two PA probes at the same time for dual probe weld inspection configurations. The probe splitter is available in two different versions: ZPAC and Omni type probe connectors.



Probe splitter module

Ordering information

Type	Part Number	Short Description	Description	Compatible with			
				TOPAZ ¹⁶	TOPAZ ³²	ZIRCON	QUZRTZ
Splitters	10048834	ZPA-ACC-SPLTBOX-ZPAC-2ZPAC64	Robust design splitter that can be attached at the back of TOPAZ. It features a fast and easy attachment system with a solid security latch. It can manage data from 2 dialog probes and to provide them to UltraVision Touch to ensure data traceability. It is also possible to use some of the phased array channels as Conventional (lines are isolated using individual switches).		√		
	10049127	ZPA-ACC-SPLTBOX-ZPAC-2OMNI64	Robust design splitter that can be attached at the back of TOPAZ. It features a fast and easy attachment system with a solid security latch. It is also possible to use some of the phased array channels as Conventional (lines are isolated using individual switches). Omni type probe connector.		√		
	10053567	ZPA-ACC-SPLTBOX16-ZPAC-2ZPAC64+4UT	ZPAC SPLITTER for TOPAZ16 with fast easy attachment system including a solid security latch. It can manage ID data from 2 Phased Array probes allowing UltraVision to track them. It includes two pairs of Lemo connectors (individually isolated with switches) to convert Phased Array lines into two Conventional Channels.	√			
	10053782	ZPA-ACC-SPLTBOX16-ZPAC-2OMNI64+4UT	Omni type SPLITTER for TOPAZ16 with fast easy attachment system including a solid security latch. The splitter includes two pairs of Lemo connectors (individually isolated with switches) to convert Phased Array lines into two Conventional Channels. Omni type probe connector.	√			
Adapters	10037251	ZPA-ACC-ADPBOX-ZPAC-OMNI	Adapter Box - Connect one Omni type PA probe connector (128 con.) to the ZIRCON and TOPAZ (ZPAC male to Omni type female)	√	√	√	√
	10037252	ZPA-ACC-SPLTCBL-ZPAC-2HYP64	Adapter Box - Connect one Hypertronics PA probe connector (128 con.) to the ZIRCON and TOPAZ (ZPAC male to Hypertronics female).	√	√	√	√
	10041164	ZPA-ACC-SPLTCBL-ZPAC16LEMO-1FT	Dedicated cable with 1 ZPAC (compatible with ZIRCON and TOPAZ) to 16 Lemo 00 - 1 ft (0.3 m) long.	√	√	√	√
Accessories	10040557	ZGN-ACC-ZPAC-ENC-5M-DE15	Mini encoder - 5 m cable - waterproof - DE15 connector compatible with ZIRCON and TOPAZ - includes bracket kit to attach on Zetec wedges.	√	√	√	√
	10053374	ZPA-ACC-TOPAZ16-FANEXT-ASSY	Fan Kit for TOPAZ16. It extends the instrument operating temperature range. Easily attached at the back of the unit without any tools and automatically controlled by TOPAZ16.	√			
	10036098	ZPA-ACC-ZIRCON/TOPAZ-CHARGER	External battery charger	√	√	√	

DYNARAY Lite®



Characteristics

Lighter than DYNARAY: All the high-performance characteristics of the DYNARAY® product line in lighter weight package.

64/64 PR: Up to 64 simultaneously active elements and up to 64 channels in total.

Flexible Inspection Setup: Up to 4,096 different focal laws with Position Dependent configuration for superior inspection quality on complex surfaces.

UltraVision® Controlled: UltraVision 3 allows performing all activities needed in an inspection process within the same package. From designing the probe and modelling the acoustic field to defining the specimen, parts to inspect and scan plan or calibration, inspection, analysis and reporting. All-in-one seamless integrated package.

3D Work Environment: Controlled by UltraVision® 3 it offers a 3-D work environment for creation of components and data visualization.

Speed matters: High data throughput, up to 20 MB/s.

Specifications

Feature	DYNARAY Lite
Size (H × W × D)	228 × 356 × 432 mm 9.6 × 14.1 × 17.5 in
Weight	13.5 kg 30 lb
Air Intake	Yes
Battery Operation	No
Phased Array Connector	2 Hypertronics
Phased Array Channels	64/64 PR
UT Channels	16
Digitizing Frequency	up to 100 MHz
Amplitude Resolution	8 or 16 bits
Measurement Gates	4 gates + 1 synchronization gate
Data Interfaces	Ethernet 1000 Base-T
Maximum PRF	30 kHz
Global Data Throughput	20 MB/sec
Max. Pulser Voltage (Open Circuit)	215 V
Max. Applied Voltage (50 ohms)	200 V
Bandwidth (-3 dB)	from 0.25 to 20 MHz
Real-time Data Compression	Yes
Rectification	Digital
Filtering	Analog/digital (FIR)
Smoothing (Video Filter)	Digital
Self-Check	Yes
Automated Probe Detection	No
Dynamic Depth Focusing (DDF)	Yes
Parallel Firing	No
Time Reversal	No
# Focal Laws	4096
Maximum Number of Samples	Up to 256,000 points can be evaluated
Amplifier	LIN, LOG (processed)
Maximum Data File Size	20 GB
Encoder Interfaces	6 quadrature-type 3 differential-type
Serves as Protection Key	License for UltraVision 3™ Basic
Data Acquisition & Analysis	UltraVision Touch™ UltraVision® 3

Ordering information

Part Number	Short Description	Description
10035391	ZPA-RDT-DYNARAY-64/64PR-LITE	DYNARAY Lite™ 64/64PR - Phased array system with up to 64 simultaneous active channels. Can use the same 64 channels as transmitters and receivers or 64 channels as transmitters and 64 others as receivers. 2 Hypertronics and 16 Lemo 00 connectors



Characteristics

2D Matrix Array Technology: Up to 256 simultaneously active elements and up to 512 channels in total

Speed Matters: High data throughput, up to 20 MB/s

Wide Range of Probe Frequencies: Drives low-frequency array probes (down to 0.5 MHz)

Flexible Inspection Setup: Up to 4,096 different focal laws with Position Dependent configuration for superior inspection quality on complex surfaces. DYNARAY offers 16-bit signal resolution of phased array and up to 100 MHz digitizing frequency

UltraVision® Controlled: UltraVision 3 allows performing all activities needed in an inspection process within the same package. From designing the probe and modelling the acoustic field to defining the specimen, parts to inspect and scan plan or calibration, inspection, analysis and reporting. All-in-one seamless integrated package.

3D Work Environment: Controlled by UltraVision® 3 it offers a 3-D work environment for creation of components and data visualization.

Speed matters: High data throughput, up to 20 MB/s.

DYNARAY is available in four Configurations:

- 64:64
- 128:128
- 64:256
- 256:256

Specifications

Feature	DYNARAY
Size (H × W × D)	381 × 356 × 457 mm 15.5 × 14.4 × 18.5 in
Weight	59 lb (27 kg) for 128/128 PR 71 lb (32 kg) for 256/256 PR
Air Intake	Yes
Battery Operation	No
Phased Array Connector	Up to 4 Hypertronics
Phased Array Channels	256/256 PR, 128/128 PR
UT Channels	Up to 256
Digitizing Frequency	up to 100 MHz
Amplitude Resolution	8 or 16 bits
Measurement Gates	4 gates + 1 synchronization gate
Data Interfaces	Ethernet 1000 Base-T
Maximum PRF	30 kHz
Global Data Throughput	up to 20 MB/sec
Max. Pulser Voltage (Open Circuit)	215 V
Max. Applied Voltage (50 ohms)	200 V
Bandwidth (-3 dB)	from 0.25 to 25 MHz
Real-time Data Compression	Yes
Rectification	Digital
Filtering	Analog/digital (FIR)
Smoothing (Video Filter)	Digital
Self-Check	Yes
Automated Probe Detection	No
Dynamic Depth Focusing (DDF)	Yes
Parallel Firing	No
Time Reversal	No
# Focal Laws	4096
Maximum Number of Samples	Up to 250,000 points can be evaluated
Amplifier	LIN, LOG (processed)
Maximum Data File Size	20 GB
Encoder Interfaces	6 quadrature-type 3 differential-type
Serves as Protection Key	License for UltraVision 3™ Basic
Data Acquisition & Analysis	UltraVision Touch™ UltraVision® 3

Ordering information

Part Number	Short Description	Description
10024414	ZPA-RDT-DYNARAY-64/64PR	DYNARAY™ 64/64PR - Phased array system with up to 64 simultaneous active channels. Can use the same 64 channels as transmitters and receivers or 64 channels as transmitters and 64 others as receivers - 2 Hypertronics and 16 Lemo 00 connectors.
10024416	ZPA-RDT-DYNARAY-128/128PR	DYNARAY™ 128/128PR - Phased array system with up to 128 simultaneous active channels. Can use the same 128 channels as transmitters and receivers or 128 channels as transmitters and 128 others as receivers. 2 Hypertronics and 16 Lemo 00 connectors.
10024417	ZPA-RDT-DYNARAY-256/256PR	DYNARAY™ 256/256PR - Phased array system with up to 256 simultaneous active channels. Can use the same 256 channels as transmitters and receivers or 256 channels as transmitters and 256 others as receivers. 4 Hypertronics and 16 Lemo 00 connectors.
10024415	ZPA-RDT-DYNARAY-64/256PR	DYNARAY™ 64/256PR - Phased array system with up to 64 simultaneous active channels and 256 in total. Can use same 64 channels as transmitters and receivers or 64 channels as transmitters and 64 others as receivers. 4 Hypertronics and 16 Lemo 00 connectors.

Accessories for DYNARAY and DYNARAY Lite Characteristics

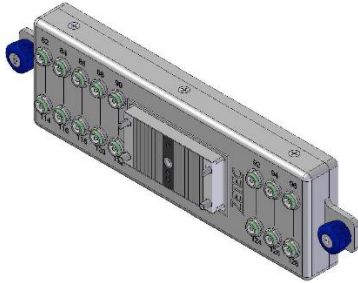

10024419 (ZPA-ACC-DYNARAY-UTADAPT1-16CH)



10040446 (ZPA-ACC-ADPBOX-DYNARAY-ZIRCON)

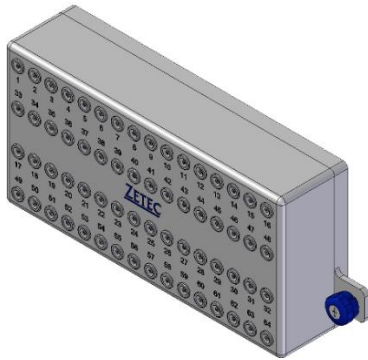

10040441 (ZGN-ACC-DYNARAY-ADPBOX-64LEMO)



10040447 (ZPA-ACC-ADPBOX-DYNARAY-OMNI)

Ordering information

Part Number	Short Description	Description
10024419	ZPA-ACC-DYNARAY-UTADAPT1-16CH	Adapter box with 16 UT channels (Lemo 00 connectors) and 1 Hypertronics connector. To be used on Hypertronics connector of DYNARAY 64/256PR, 128/128PR and 256/256PR. NOTE: This item is also included with each DYNARAY system.
10024420	ZPA-ACC-DYNARAY-UTADAPT2-16CH	Adapter box with 16 UT channels (Lemo 00 connectors) and 1 Hypertronics Connector to be used on Hypertronics connector of DYNARAY 64/64PR. This item is also included with the DYNARAY 64/64PR and the DYNARAY Lite 64/64PR
10040441	ZGN-ACC-DYNARAY-ADPBOX-64LEMO	Adapter Box - 1 DYNARAY- compatible male connector to 64 Lemo 00 female connectors
10040255	ZPA-ACC-ADPBOX-DYNARAY-ZPAC	Adapter Box - Connect one ZPAC compatible PA probe connector to the DYNARAY (Hypertronics) (DYNARAY male to ZPAC female connector, 128 connections.
10040447	ZPA-ACC-ADPBOX-DYNARAY-OMNI	Adapter Box - Connect one OMNI-type PA probe connector to the DYNARAY (Hypertronics)

Z-Scan UT



Characteristics

High-performance multi-channel UT system, controlled by UltraVision® 3

Supports Pulse-Echo and TOFD

High data throughput (5 Mbytes/s)

Pulser voltage: 300 Volts

12-bit 100 MHz A/D converter

Sealed enclosure

Dual Operation, for up to 16 simultaneous UT channels

Ordering information

Part Number	Short Description	Description
10037866	ZUT-RDT-ZSCAN-2CH-LEMO	Z-Scan UT system, 2 conventional UT channels: 2 pulsers and 2 receivers with Lemo 00 connectors. Includes transport case.
1350-00-2022	ZUT-RDT-ZSCAN-2CH-BNC	Z-Scan UT system, 2 conventional UT channels: 2 pulsers and 2 receivers with BNC connectors. Includes transport case.
1350-00-2041	ZUT-RDT-ZSCAN-4CH-LEMO	Z-Scan UT system, 4 conventional UT channels: 4 pulsers and 4 receivers - with Lemo00 connectors. Includes transport case.
1350-00-0043	ZUT-RDT-ZSCAN-4CH-BNC	Z-Scan UT system, 4 conventional UT channels: 4 pulsers and 4 receivers with BNC connectors. Includes transport case.
1350-00-0081	ZUT-RDT-ZSCAN-8CH-LEMO	Z-Scan UT system, 8 conventional UT channels: 8 pulsers and 8 receivers with Lemo 00 connectors. Includes transport case.
1350-00-0083	ZUT-RDT-ZSCAN-8CH-BNC	Z-Scan UT system, 8 conventional UT channels - 8 pulsers and 8 receivers with BNC connectors. Includes transport case.

Motor Controllers

ZMC2



Characteristics

ZMC² is a fully programmable, 2-axis servo motor control drive unit with a built-in controller.

Fully Programmable 2-axis Servo Drive: GALIL architecture allows for an almost infinite number of scanning patterns including one-line, bidirectional, raster, helical and more. The unit is available with drivers for DC servomotors. ZMC² interfaces with standard computers and may be used with all ZETEC acquisition systems or third-party systems. ZMC² is compatible with previous motor control units for an easy upgrade of your system.

Software Control: The unit comes with the ZMC² Control software, a standalone software that allows to program and operate the motion controller. Or can be seamlessly integrated with the UltraVision software.

Rugged & Fan-less Design: In a compact and robust casing with no air exchange, this motor controller can be deployed even in contaminated areas.

Remote Control: A fully capable remote control is included with the motion control unit.

Specifications

Feature	ZMC ²
General Specifications	
Controller type	2-axis closed loop servo drive 2 encoder inputs (TTL, Differential or Optocoupler)
Ethernet port	2 RJ-45 ports, Gigabit Ethernet 1000Base-T
Control lines	Limit switches (2positives, 2 negatives) 2 programmable outputs optocouplers (5V) and TTL (5V) 2 programmable inputs optocouplers (5V) and TTL (5V) 2 programmable analog input ($\pm 10V$) 5V/2.4A output +12V/1A and -12V/0.25A 2 dry contacts 30VDC/2A
Housing	
Dimensions (W x H x D)	244 x 358 x 305 mm 9.6 x 14.1 x 12 in
Weight (including remote control)	9.5 kg 21 lb
Environment	
Operating temperature:	0°C to 40°C (32°F to 104°F)
Storage temperature	-20°C to 70°C (-4°F to 158°F)
Servo Driver Specifications	
Output voltage (maximum)	22.5V or 45V
Output current (maximum)	4A per axis
Motor type	DC brushed
Protection	Short-circuit, overvoltage, overcurrent, overheating, Max output
Power Supply Input	
Voltage	100-240VAC
Frequency	50Hz to 60Hz
Max power	380 VA
MAINS supply voltage fluctuations	Up to $\pm 10\%$ of the nominal voltage. Overvoltage category II
DC out	
Motors	24 V or 48 V (Max 4A per axis)
Output power:	Short term (1min.): 240W Intermittent (TON \leq 3min., Duty Cycle \leq 25%): Max 150W Continuous: 155W at 23°C (73.4°F)
Other outputs	+5V/2.4A +12V/1A -12V/0.25A

ZMC4



Characteristics

ZMC⁴ is a fully programmable, 4-axis servo motor control drive and battery-operated unit. Based on GALIL architecture, it allows for several of scanning patterns: one-line, bidirectional, raster, helical and more.

The unit is available with drivers for DC servomotors. ZMC⁴ interfaces with standard computers and may be used with all ZETEC acquisition systems or third-party systems and integrates perfectly with a TOPAZ system.

A compact and robust casing with IP67 rating allows ZMC⁴ to be deployed anywhere, even in contaminated. ZMC⁴ comes with a remote control that allow you to fully control your scanning mechanism.

ZMC⁴ has been seamlessly integrated with the UltraVision software. You can benefit from the capabilities and flexibility of an industry leading software for your ultrasound inspection and the control of your automated scanning mechanism.

General Specifications

Feature	ZMC ⁴
General Specifications	
Controller type	4-axis closed loop servo drive 8 encoder inputs (TTL)
Ethernet port	1 RJ-45 ports, 100 Base-T Ethernet
Control lines	Limit switches (4 forwards, 4 backwards) 2 programmable outputs (Open collector 5V, 25mA) 2 programmable logic inputs TTL (5V, sink 2.5mA)
Housing	
Dimensions (W x H x D)	284 x 228 x 154 mm 11.2 x 9.0 x 6.1 in D=18.6cm (7.3in) with handles
Weight	6.0 kg (13.3 lbs) without batteries 7.0 kg (15.4 lbs) with batteries
Environment	
Operating temperature:	0°C to 45°C 32°F to 113°F
Storage temperature	-20°C to 60°C -4°F to 140°F
Ingress Protection	IP67
Servo Driver Specifications	
Motor type	DC brushed and brushless
Protection	Short-circuit, overvoltage, overcurrent, overheating, Max output
Power Supply Input	
Voltage	100-240 VAC. Main supply voltage fluctuations up to ±10% of the nominal voltage. Transient overvoltage II
Frequency	50 Hz or 60 Hz
DC OUT	15V/6.7A
Maximum power	100 VA
Battery type	Li-ion battery (Rechargeable pack) Voltage 10.8V Capacity 7800mAh
Number of batteries	up to 2 (battery chamber can hold 2 hot-swappable batteries)
Battery life	Up to 8 hours with two batteries (depending on load)
Power Output	
Motors	24 V
Output power	Short term transient (<3sec): 2A/axis non repetitive (less 2 cycle/min). Continuous: 1.5A/axis but limited by total available power (50W on AC/DC adapter or 20W on batteries)
Other outputs	+5V/0.44A

Ordering information

Part Number	Short Description	Description
10036297	ZGN-CTR-ZMC2	ZMC2 precision Motion Control unit, 2-axis drive for 1 or 2 axis scanners. Output voltage of 24V or 48V, including remote control and standalone software.
10049252	ZGN-CTR-ZMC4	ZMC4 battery operated motor controller capable to manage up to 4 axes. Designed to accommodate the needs to motorize the WELD CRAWLER, the ZMC4 is directly controlled from the TOPAZ front panel.

UltraVision Software

Overview

UltraVision is an integrated software that manages all activities in an ultrasonic inspection process. UltraVision software controls the acquisition of ultrasonic (UT) signals, displays real-time imaging and provides online and offline data analysis.

UltraVision software drives all Zetec's phased array and conventional UT systems offering complete integration and portability of setup and data across all acquisition platforms.

UltraVision also offers many advanced features and tools that improve the efficiency of UT inspections.

The integrated 3D work environment allows performing ray tracing and beam simulations to determine detection capability and inspection coverage. It also offers analysis features that include the visualization of the inspection data in the actual component, detection of suspected indications as well as the discrimination between actual flaw indications and signals originating from component geometry and weld structure.

UltraVision helps sizing flaws and delivers comprehensive reporting of inspection parameters and inspection results.

UltraVision is the ideal tool for either on-site inspections or lab work, handling data files with 16-bit amplitude resolution and up to 20 GB.

The Software Development Kit (SDK) allows advanced users to develop and implement their own features and components.

Preparation of the examination in a 3D world

UltraVision **Component Generation** offers an extensive database of predefined configurable components, allows to import a suitable CAD file (*.SAT) or create a specimen by using the manual surface profile tool. Defects can be added to interact with incident rays. 3D visualization of the components allows to better prepare the inspection configuration.

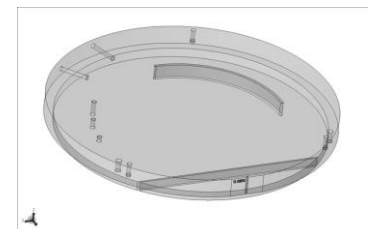

3D Ray Tracing tool computes and displays 3D ultrasound rays propagating in the specimen. The ray paths can undergo reflection and transmission, including mode conversions and interacting with postulated defects in simple or complex geometries. UltraVision can automatically find the optimum acoustical path for reflection based on the shortest path.

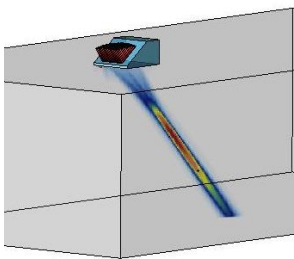

Beam Simulation allows computing, visualizing and characterizing the energy distribution in the acoustic beam generated by a given probe including single element (conventional UT), 1D linear array and 2D matrix arrays.

The **Weld/Specimen Overlays** superposes accurate predefined or CAD drawings of the weld or specimen geometry on the examination data, in 2D or 3D views.

UltraVision **Scanner Tool** emulates the scanner motion on the component and helps to establish the inspection coverage.

The **Advanced Focal Law Calculator** generates the phased array beams for 1D and 2D array probes including flexible array probes and also TOFD configurations. Using the 3D display of the probe configuration and the specimen, it is possible to verify and validate the inputs and the resulting focal laws.

The **Calibration Tool** performs automated calibration (amplitude and time base) and TGC creation for both conventional UT and phased array UT channels.

Advanced Data Analysis

Volumetric Dynamic Views deliver real-time display of various view type: From Top-, Side- and End-views to Dynamic Polar view and Sectorial Scan. Fully customizable layouts can be created and saved including overlays, information fields, color palette and software gain settings.

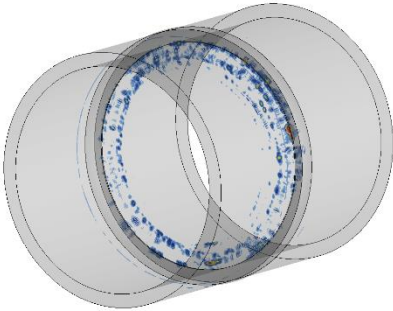

Ultrasonic data acquired with various acoustic beams can be merged using the **Volumetric Merge** tool. This process creates a new data group with the maximum amplitude information observed for each scanned point and supports the 3D visualization.

Using the **3D Data visualization**, acquired data is plotted within the specimen for 3D realistic visualization and accurate positioning of relevant indications. Using the **3D Plotting of C-Scan** tool it is possible to visualize Gate C-Scans on

a 3D view, giving the user an easier and better way to analyze and represent the data.

Assisted Analysis provides automatic detection of indications based on user-defined criteria such as signal-to-noise and minimum indication size. The **Freeform Contour** can be used to create appropriate contours around indications that are not limited to a rectangular shape.

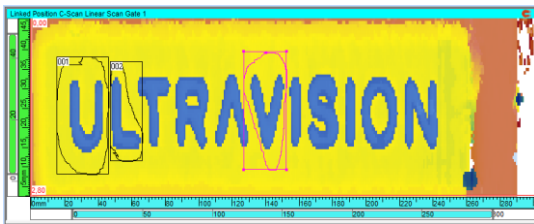
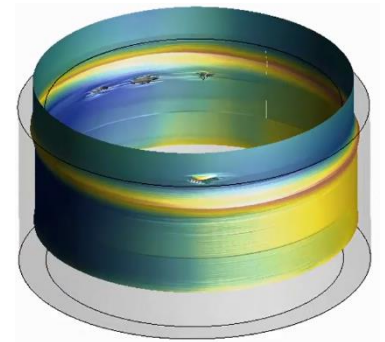

Indication Table helps to create a list of relevant indications. For each entry, user can select a set of information fields (size, amplitude, location, etc.) that will be associated with the indication and assign a status. It also possible to attach a screen capture of the indication and generate reports.

A comprehensive **Reporting tool** allows creating complete and professional reports, containing acquisition configuration settings, and the information listed in the indication table. The **"Slice" Report tool** creates data slices from a single inspection scan for easier data presentation.

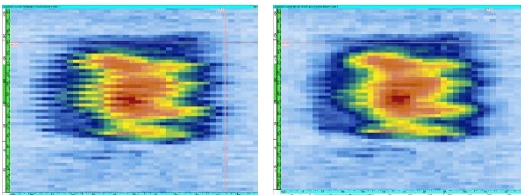

Advanced Signal Processing like Hysteresis Correction, Geometric Echo Removal, Logarithmic/Linear data conversions and Median Filtering are some of the tools to help improving signal quality and optimizing the inspection results.

When inspecting a large surface, data can be separated in different data files and then combined together using the **Data Stitching** feature.

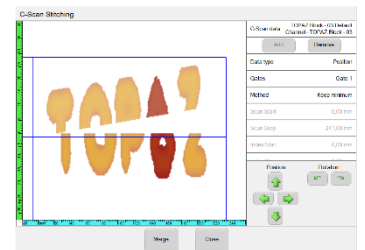

Gates could be set to **Autocrossing** mode where the detection threshold is changed according to the maximum signal amplitude detected within the gate.

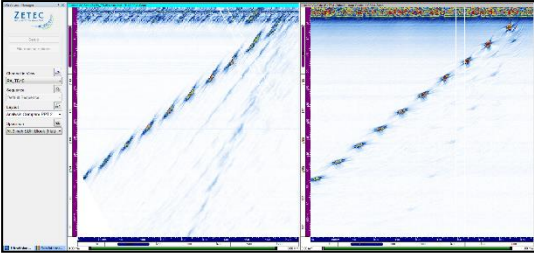

When using DYNARAY, UltraVision can perform **Full Matrix Capture (FMC)** data-acquisition where each array element is sequentially used as a single emitter and all array elements are used as receivers creating a matrix A-Scan data strings. **Total Focusing Method (TFM)** analysis this data to calculate focal laws generating an image perfectly focused at all points in the region of interest.

Reliable and Secure

The administrator of the software can create new users and assign them different **User Rights**. Essential UT parameter settings can be secured by procedure developers while leaving other parameters accessible for site operators with limited training.

Log Viewer registers user actions and system events with a time stamp and a complete description of the logged events allowing to review the tasks performed with UltraVision.

Raw Data Protection ensures modifications and processed data are stored in extension files to protect the integrity of the original raw data.

The Message Board presents useful information such as the validity of your instrument calibration, or site license renewal information.

UltraVision versions

	UltraVision Touch			UltraVision Classic		
	Viewer	Basic	Advanced	Basic	Advanced	3D
INSPECTION PREPARATION - Specimen and Overlay Management						
Creation of basic geometries with automatic overlays		√	√	√	√	√
Configurable predefined basic specimens (plate and pipe, with or without welds)		√	√	√	√	√
Predefined weld bevels: V, X, modified V, J and K		√	√	√	√	√
Configuration of HAZ around weld bevel		√	√	√	√	√
Manual import of DXF overlay		√	√	√	√	√
Custom specimen load (SAT) *						√
Auto-overlay line style		√	√	√	√	√
Support of complex geometries with manual overlays						√
Configurable predefined complex specimens (connecting pipe, nozzles, cruciform, T, L joints...)						√
Specimen generator from scanned profile (from mechanical profile gage)						√
Manual specimen creation tool						√
Import from ESBeam tool: extrusion generation from closed form (polygon)						√
Scanner creation tool						√
3D ray-tracing with postulated defects (specular reflection tool)						√
Angle optimization for specular reflection on complex geometry						√
Saddle weld automatic skew compensation (nozzle-to-shell)						√
Liquid gap under wedge - compensation tool						√
INSPECTION PREPARATION - Advanced Focal Law Calculator						
Probe, wedge, material database		√	√	√	√	√
Extended probe database support including other vendors' models		√	√	√	√	√
1D linear probe creation in database		√	√	√	√	√
2D matrix probe creation in database			√	√	√	√
Custom probe design support through .xml file					√	√
Graphical feedback on focal law generation		√	√	√	√	√
Focal law calculation for 1D probes on plate and pipe		√	√	√	√	√
Focal law calculation for 2D probes on plate and pipe			√	√	√	√
Focal law calculation for custom probes on plate and pipe					√	√
Focal law calculation for 1D and 2D flexible arrays and custom contoured wedges on complex surfaces						√
Theoretical beam information: exit and focal point X, Y and Z				√	√	√
Theoretical refracted, skew and steering angles				√	√	√
Theoretical near-field depth				√	√	√
Full control of element delays and activation				√	√	√
Parametrized wedge CAD export function				√	√	√
Conventional TOFD		√	√	√	√	√
PA Pulse-Echo mode		√	√	√	√	√
PA Pitch & Catch mode		√	√	√	√	√
Self-Tandem PA				√	√	√
Tandem PA				√	√	√
Sectorial scanning		√	√	√	√	√
Linear scanning		√	√	√	√	√
Compound scanning		√	√	√	√	√
DDF (Dynamic Depth Focusing)			√	√	√	√
Generate .law files				√	√	√
Load .law files		√	√	√	√	√
Acoustic beam simulation conv. UT probes on plate and pipe					√	√

	UltraVision Touch			UltraVision Classic		
	Viewer	Basic	Advanced	Basic	Advanced	3D
Acoustic beam simulation 1D and 2D probes on plate and pipe					√	√
Acoustic beam simulation custom probes on plate and pipe					√	√
Acoustic beam simulation on complex surfaces						√
Simulated beam information: exit and focal point X, Y and Z					√	√
Simulated beam information: refracted and skew angles					√	√
Simulated acoustic field: focal zone information (-6dB)					√	√
DGS curve simulation conv. UT probes on plate and pipe					√	√
DGS curve simulation 1D and 2D probes on plate and pipe					√	√
DGS curve simulation custom probes on plate and pipe					√	√
INSPECTION - Setup Building						
Views: A-Scan, Uncorrected B, C, D-Scan, Volume Corrected B, C, D-scan, TOFD, Amplitude & Position C-scan, Sectorial, Real-time Merged, FFT		√	√	√	√	√
View properties customization (envelope, smoothing, units, overlays, links between views...)		√	√	√	√	√
Load predefined Layout		√	√	√	√	√
Proposed file naming		√	√	√	√	√
Self-diagnostic for TOPAZ, ZIRCON, Quartz and DYNARAY		√	√	√	√	√
Automatic probe detection		√	√	√	√	√
User rights				√	√	√
PRF optimization recommendation		√	√	√	√	√
Homing gates		√	√	√	√	√
Auto-crossing gates		√	√	√	√	√
TCG curve		√	√	√	√	√
DGS curve					√	√
Linear amplification				√	√	√
Logarithmic amplification (with DYNARAY)				√	√	√
Unlimited # channels (groups)		√	√	√	√	√
Propose Setup feature for weld inspection (PA UT & TOFD)		√	√	√	√	√
Propose Setup feature for corrosion		√	√	√	√	√
Probe position marker		√	√			
INSPECTION - Calibration tools						
Encoder, TOFD, PA wedge delay, sensitivity, TCG, element check for multiple channels		√	√	√	√	√
Calibration block definition				√	√	√
INSPECTION - Mechanical sequences						
Single point (free running)		√	√	√	√	√
Internal clock one-line sequence		√	√	√	√	√
One-line sequence		√	√	√	√	√
Bi-directional sequence (raster)		√	√	√	√	√
Helicoidal sequence				√	√	√
Polar sequence				√	√	√
PaintBrush sequence (on TOPAZ and ZIRCON)		√	√	√	√	√
INSPECTION - Data Recording						
8, 12 or 16 bits		√	√	√	√	√
Data file size up to 20GB (on a workstation)		√	√	√	√	√
A-scan length up to 256 000 points per A-scan (with DYNARAY)				√	√	√
Real time merged views		√	√	√	√	√
Camera support		√	√	√	√	√
Multi-unit operation				√	√	√
Support motion controller ZMC2 and MCDU				√	√	√
Support motion controller ZMC4		√	√	√	√	√
Acquisition start, pause stop from external input		√	√	√	√	√

	UltraVision Touch			UltraVision Classic		
	Viewer	Basic	Advanced	Basic	Advanced	3D
FMC, elementary A-Scan capture (with DYNARAY)					√	√
Position Dependent focal law groups (with DYNARAY)						√
Firing Sequencer				√	√	√
Time Reversal support (with TOPAZ32, ZIRCON and Quartz)			√	√	√	√
DATA ANALYSIS - Views						
A-Scan, B-Scan, C-Scan D-scan, FFT, uncorrected, corrected, merged & TOFD views	√	√	√	√	√	√
Layout management: customize, save & reload		√	√	√	√	√
Load predefined Layout	√	√	√	√	√	√
UT Parameters, Mechanical Parameters Review	√	√	√	√	√	√
Conversion from Cartesian to polar or custom reference system						√
DATA ANALYSIS – Basic tools						
Slicing cursors	√	√	√	√	√	√
Basic measurement tools: cursors, rectangular contour	√	√	√	√	√	√
Information Fields	√	√	√	√	√	√
Customized Info Field with dynamic link to Excel				√	√	√
Echo-dynamic curves				√	√	√
DATA ANALYSIS - Processing tools						
Scan axis calibration tool for internal clock one-line sequence		√	√	√	√	√
Automatic amplitude-drop sizing tool of indication in contour		√	√	√	√	√
Freeform measurement and sizing contour				√	√	√
TOFD processing: LW synchronization, LW removal, SAFT		√	√	√	√	√
Log-to-Linear and Linear-to-Log conversion				√	√	√
Hysteresis (backlash) correction				√	√	√
Geometric Echo removal				√	√	√
Assisted Analysis tool					√	√
Data file Merger		√	√	√	√	√
Data file Splitter				√	√	√
Volumetric Merge, with interpolation and smoothing options		√	√	√	√	√
Information Views for corrosion mapping		√	√	√	√	√
Corrosion mapping: thickness threshold		√	√	√	√	√
Corrosion mapping: thickness distribution histogram				√	√	√
Color Palette Editor				√	√	√
C-Scan data stitching		√	√	√	√	√
C-Scan processing: smoothing, 3D rendering					√	√
3D data merge and plotting (plate and pipe geometries)					√	√
3D data merge and plotting (complex geometries)						√
Software beam summation for FMC data					√	√
TFM (Total Focusing) algorithms for FMC data					√	√
DATA ANALYSIS - File management						
Export data to text/Excel file		√	√	√	√	√
Automatic batch Volumetric Merge (BVM) execution in folder				√	√	√
Auto-load UVDisplay file				√	√	√
REPORTING						
Define User Info Fields		√	√	√	√	√
Actions Log File				√	√	√
Screen capture tool	√	√	√	√	√	√
Indication Table	√	√	√	√	√	√
Export Indication Table to Text File	√	√	√	√	√	√
Reporting Tool	√	√	√	√	√	√

Ordering Information

Part Number	Short Description	Description
10046278	ZPA-SWS-UV-TOUCH	UltraVision Touch. Running on a computer, UltraVision Touch allows inspection preparation, data acquisition, data analysis and reporting in the same “Touch” friendly environment than TOPAZ. Includes User Manual.
10053454	ZPA-SWS-UV-TOUCH-ADV	UltraVision Touch Advanced. Running on a computer, UltraVision Touch allows inspection preparation, data acquisition, data analysis and reporting including 2D matrix array support in the same “Touch” friendly environment than TOPAZ. Includes User Manual.
10024700	ZPA-SWS-UV-3-BASIC-USB	UltraVision 3 Software - Basic Version - USB Hard Key - Ultrasound data acquisition and analysis software, supports basic phased array and conventional UT applications - Includes User Manuals
10024701	ZPA-SWS-UV-3-ADV-USB	UltraVision 3 Software - Advanced Version - USB Hard Key - Ultrasound data acquisition and analysis software, supports advanced phased array and conventional UT applications - Includes User Manuals
10024702	ZPA-SWS-UV-3-3D-USB	UltraVision 3 Software - 3D Version - USB Hard Key - Ultrasound data acquisition and analysis software, supports 3D data visualization, advanced phased array and conventional UT applications - Includes User Manuals
10027456	ZPA-SWS-UV-3-DOC1-EN	UltraVision 3 User Manual - Getting Started - English
10031080	ZPA-SWS-UV-3-DOC2-EN	UltraVision 3 User Manual - Setup & Inspection - English
10031082	ZPA-SWS-UV-3-DOC3-EN	UltraVision 3 User Manual - Analysis & Reporting - English
10033359	ZPA-SWS-UV-3-SDK	Software development tool for UltraVision 3, can be used in combination with one or more Advanced and 3D versions of UltraVision 3; includes documentation, 40 hours of mandatory training at the Zetec facility in Québec, and a bank of 16 hours of remote support
10036507	ZPA-SWS-UV-3-SDK-OS	Software development tool for UltraVision 3, can be used in combination with one or more Advanced and 3D versions of UltraVision 3; includes documentation, 40 hours of mandatory training on-site at customer facilities, and a bank of 16 hours of remote support
10041700	ZPA-SWS-UV-3-FILE-SDK	Software development tool to access UltraVision 3 data file content; includes documentation and source code library.

Ultrasonic Scanners

Notes: Color codes are used to identify material included in each configuration as follows:

- Grey: Material included in the kit described.
- Blue: Material included in order kit (usually the Base Kit)

WELD Crawler

WELD CRAWLER is a manually-driven encoded scanning system for the inspection of welded plates or circumferentially welded pipes and that is equipped with magnetic wheels that have individual breaks (turn the knob clockwise to apply the break). The position locking mechanism allows for sliding each wheel along the main support rail and fixing it at the desired location.

Engraved ruler markers simplify the position referencing of the probes for inspection according the positions defined in UltraVision TOUCH by the Proposed Setup tool. This rail includes metric and imperial (U.S.) units with the zero position (origin) in the middle of the support rail.

An easy liftoff lever helps removing the scanner from a component. With limited amount of force, pulling the lever lifts one side of the scanner off the surface and makes it easier to remove it from examined component.

The Base Kit configuration can provide examination coverage for thicknesses up to 2-inch using PAUT and/or TOFD inspection techniques. For thicker components, more probes and modification to the support frame are required.

WELD Crawler Base Kit

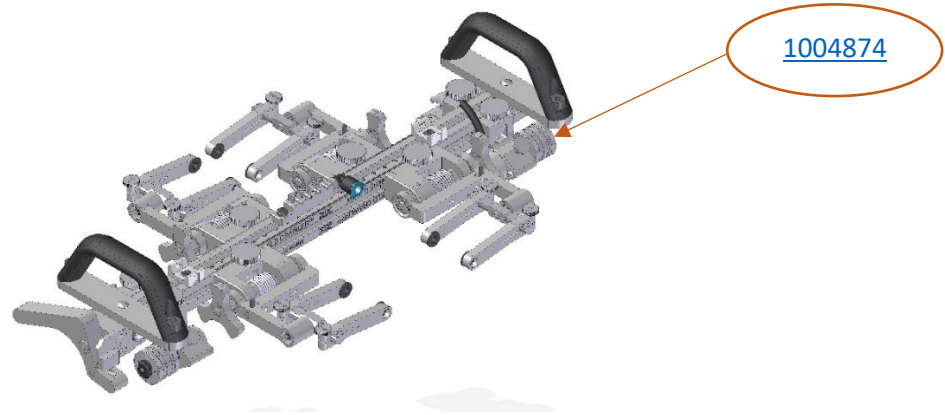

Longitudinal Weld Scanning Option

WELD CRAWLER Basic Kit can be modified in order to inspect longitudinal welds. The longitudinal weld scanning option is a dedicated frame body to which you attach the probe suspensions and forks as well as the wheels and encoders.

Like the basic *WELD CRAWLER*, the Longitudinal Weld Scanning option can provide examination coverage for thicknesses up to 2-inch using PAUT and/or TOFD inspection techniques.

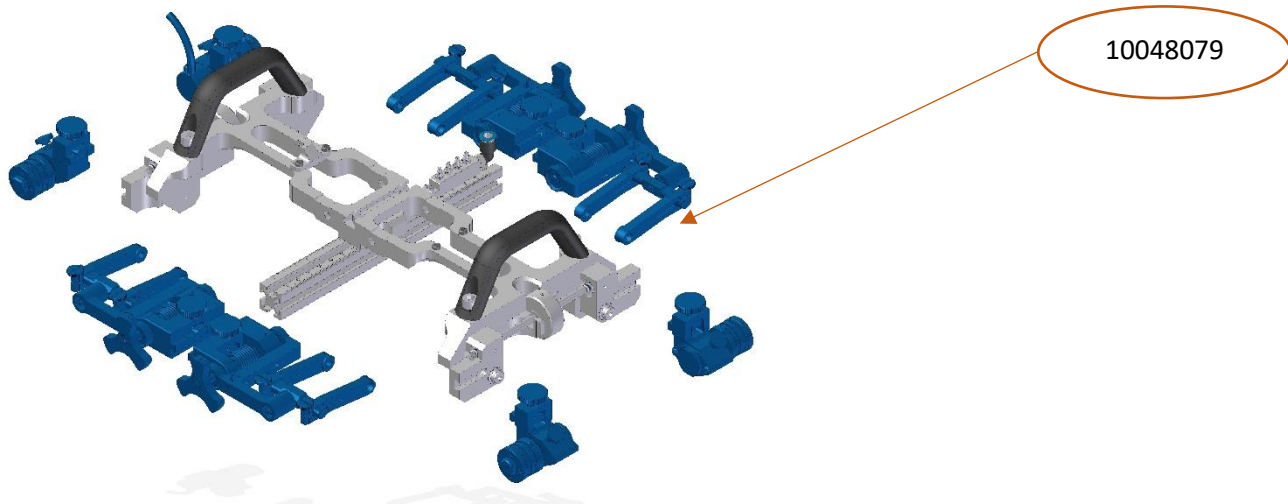

Note: Parts in blue are included in WELD Crawler Basic Kit

Wall Thickness Range extension to 2 to 4 in

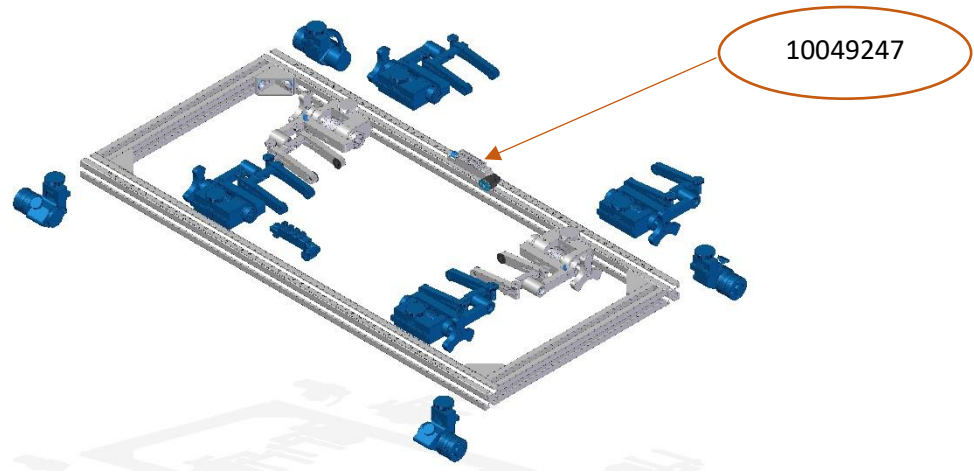

Note: Parts in blue are included in WELD Crawler Basic Kit

Wall Thickness Range extension to 4 to 6 in

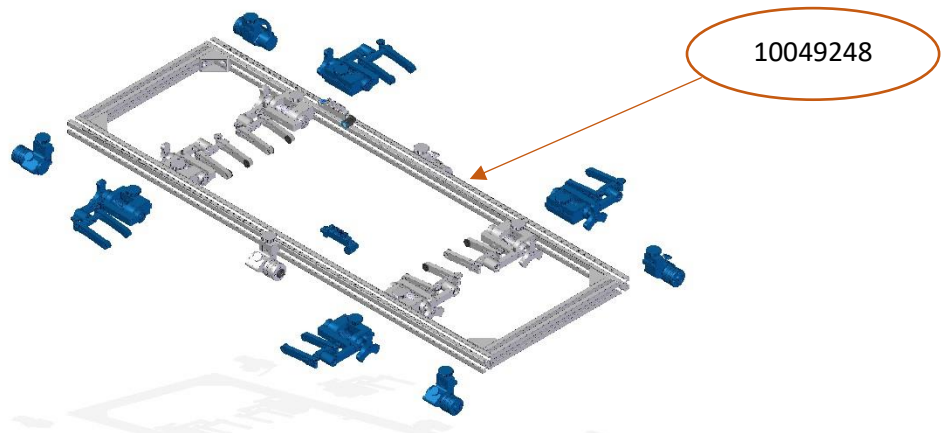

Note: Parts in blue are included in WELD Crawler Basic Kit

Chain Option

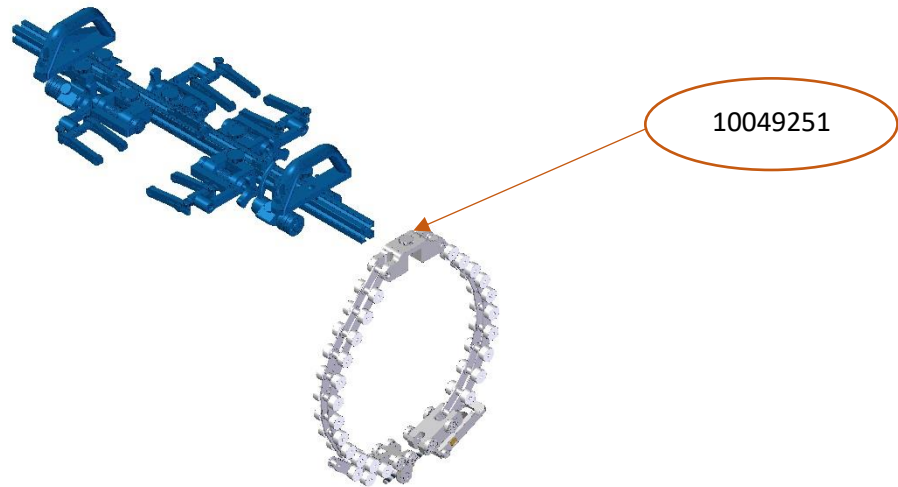

Note: Parts in blue are included in WELD Crawler Basic Kit

Camera and Laser option

Camera and Laser option consists of:

- **Video Camera** kit that consists of two (2) small video cameras whose feed can be displayed TOPAZ32 interface. The video feed allows to monitor probes and the component surface conditions while scanning. The video feed can be saved with the data file for review during data analysis.
- **Laser kit** provides with an effective tool for accurately positioning the scanner and allowing to center the device with the weld center line. It also allows to monitor for lateral drift of the scanner during the examination.
- **Video Camera adapter** box.

The video cameras are plugged-in a dedicated link box transferring the video feed to TOPAZ 32 through a USB connection. The video camera connection box can be attached, using the included fastener, to the TOPAZ32. Both the video cameras and the laser are powered through TOPAZ USB connections.

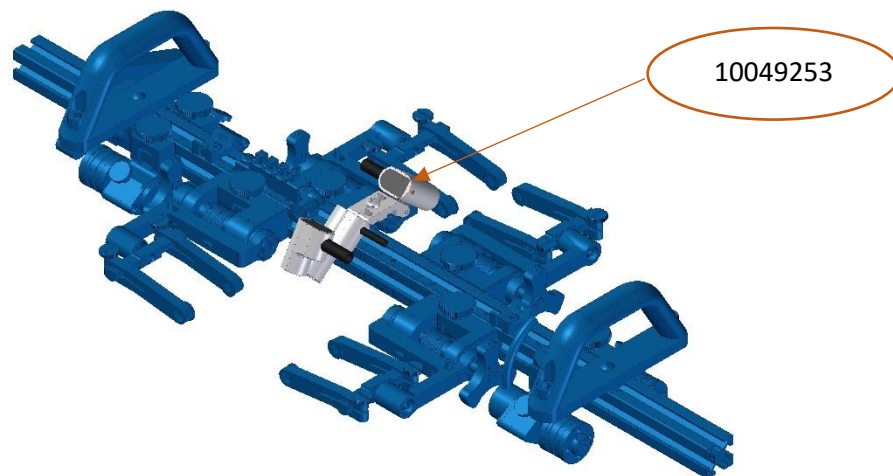

Note: Parts in blue are included in WELD Crawler Basic Kit

Motorization option

Motorization option includes 2 powerful micro motors (ZGN-SCN-WELD CRAWLER-MOTOR) and battery operated motion controller ZMC4 (ZGN-CTR-ZMC4). Its Axial weld option (ZGN-SCN-WELD CRAWLER-OPT-AXIAL) or the 2 different frames. The motorized solution is directly controlled from the Topaz front panel. Its unique designed featuring 2 motors and 4 encoders automatically correct deviation due to obstacles. It is also possible to actively compensate drift using the 2 motors.

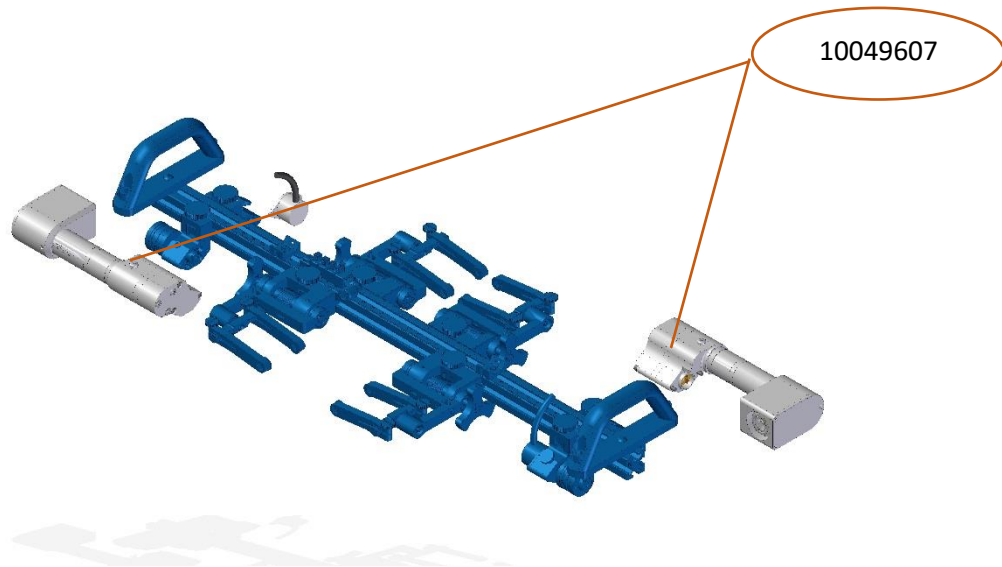

Note: Parts in blue are included in WELD Crawler Basic Kit

Ordering Information

Part Number	Short Description	Description
10048744	ZGN-SCN-WELD CRAWLER	Weld Crawler is a Manual Weld scanner for pipes from NPS 2 1/2 up to flat. ZETEC's WELD CRAWLER is a low clearance design (2" 1/4) embedding four magnetic wheels with individual break system. The WELD CRAWLER also features an integrated lever for easy lift off from pipe or plate. Its dialog encoder provides automatic encoder information programming within Ultra Vision Touch. The WELD CRAWLER features 4 individual probe suspensions with individual tensioning adjustment that allows covering welds up to 2 inches thick.
10049247	ZGN-SCN-WELD CRAWLER-OPT-THK 2 TO 4	The 2 to 4 inches option combined to the WELD CRAWLER (ZGN-SCN-WELD CRAWLER) covers thicknesses up to 4 inches. The kit features 2 additional probe suspensions to accommodate 2 more probes. The kit supports up to 6 probes.
10049248	ZGN-SCN-WELD CRAWLER-OPT-THK 4 TO 6	The 4 to 6 inches' option combined to the WELD CRAWLER (ZGN-SCN-WELD CRAWLER) and combined the 2 to 4 inches' option (ZGN-SCN-WELD CRAWLER-OPT-THK 2 TO 4) covers thicknesses up to 4 inches. The kit features 2 additional probe suspensions to accommodate 2 more probes and 2 additional wheels. The kit supports up to 8 probes and has 6 wheels.
10049251	ZGN-SCN-WELD CRAWLER-OPT-CHAIN	The optional Chain can be adapted to the WELD CRAWLER (ZGN-SCN-WELD CRAWLER). The chain can be used to up to 48" pipe diameter.

Part Number	Short Description	Description
10048079	ZGN-SCN-WELD CRAWLER-OPT-AXIAL	The axial weld solution option allows axial weld inspection using the WELD CRAWLER base (ZGN-SCN-WELD CRAWLER). The design cover longitudinal welds down to NPS 6.
10049253	ZGN-SCN-WELD CRAWLER-OPT-VISION	The Vision kit featuring 2 micro cameras and a laser is designed to be mounted on the WELD CRAWLER base (ZGN-SCN-WELD CRAWLER) without any interference. The 2" 1/4 clearance is maintained (2" 1/2 with the laser). The live images from the 2 cameras are streamed to UltraVision Touch and are displayed on the TOPAZ screen allowing remote visualization of the probes and of the Weld. Moreover, these streamed live image are recorded within the UltraVision data file and are available for review during post processing. In case of use in direct bright sunlight it is possible to load software overlays to emulate the laser beam. The Vision Kit is also fully compatible with the axial Weld option (ZGN-SCN-WELD CRAWLER-OPT-AXIAL).
10049607	ZGN-SCN-WELD CRAWLER-OPT-MOTOR	The motorization option features 2 powerful micro motors (ZGN-SCN-WELD CRAWLER-MOTOR), the ZMC4 (ZGN-CTR-ZMC4) our new battery operated motion controller and the required accessories to motorize the ZETEC's WELD CRAWLER (ZGN-SCN-WELD CRAWLER), its Axial weld option (ZGN-SCN-WELD CRAWLER-OPT-AXIAL) or the 2 different frames. The motorized solution is directly controlled from the Topaz front panel. Its unique designed featuring 2 motors and 4 encoders automatically correct deviation due to obstacles. It is also possible to actively compensate drift using the 2 motors.
10049608	ZPA-SCN-WELD CRAWLER-KIT	This WELD CRAWLER KIT features the WELD CRAWLER, the Axial Weld Kit, the 2 to 4 Inches Kit, the 4 to 6 inches Kit, the chain, the Vision Kit, the Motorization Kit, the ZPAC Splitter, the UltraVision Touch Weld Option and the Irrigation pump.
10052962	ZUT-SCN-WELD CRAWLER-SPARE PART-KIT	The kit includes Weld Crawler left & right Fork Assembly, left & right Wheel Assembly, Encoder & Irrigation collector.
10049609	ZPA-SCN-WELD CRAWLER-TOPAZ-KIT-P	This Weld Inspection Kit features a TOPAZ 32/128 and the WELD CRAWLER KIT.
10049610	ZPA-SCN-WELD CRAWLER-TOPAZ-KIT-PR	This Weld Inspection Kit features a TOPAZ 32/128 PR and the WELD CRAWLER KIT.

NDT PaintBrush

NDT PaintBrush is a 2D scanner that can perform Free Motion Scan Pattern. NDT PaintBrush can move freely over the surface to examine. With both wheels in contact with the surface to examine, NDT PaintBrush can track in real time the its apposition and any direction changing properly repositioning inspection data.

NDT PaintBrush has two buttons for simplifying typical actions:

- Left button controls the data acquisition pause, allowing to move the scanner without acquiring data while keeping track of the encoded position feedback information. A second click will restart the data acquisition.
- Right button controls the couplant flow from the from the Autonomous Irrigation Pump unit.



Configuration options

Pitch / Catch – Large aperture

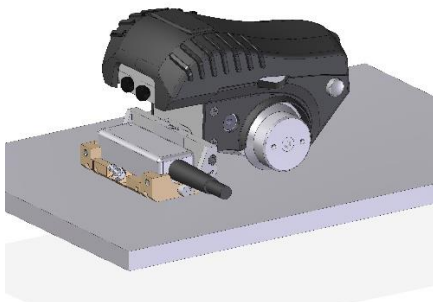

NDT PaintBrush & probe 10053850
& Probe holder 10050956

Pulse-Echo

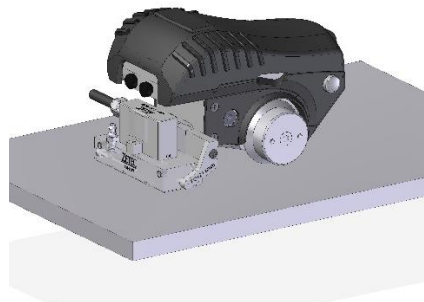

NDT PaintBrush & probe 10039141
& Wedge 10050954

Pitch / Catch - Small aperture

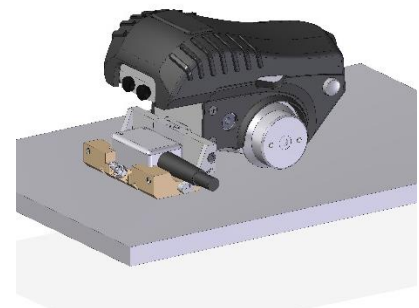

NDT PaintBrush & probe
& Probe holder 10052071

Ordering Information

Part Number	Short Description	Description
10051394	ZGN-SCN-PAINTBRUSH-BASE KIT	Corrosion NDT Paintbrush scanner including magnetic wheels configuration for carbon steel inspection & encoder cable, length 5 m. NDT Paintbrush scanner supports scanning on flat or curved surfaces (4" or bigger in diameter). Dedicated UltraVision Touch and UltraVision 3 features for controlling the NDT Paintbrush will be activated by connecting the NDT Paintbrush scanner to the TOPAZ. Kit includes tools for scanner maintenance and transport box.
10050952	ZGN-ACC-PTBR-MAGWHEEL	Magnetic wheels replacement kit for NDT Paintbrush scanner
10050953	ZGN-ACC-PTBR-NOMAGWHEEL	Non-magnetic wheels replacement kit for NDT Paintbrush scanner

Note: See Probes & Wedges Section for compatible corrosion probes and accessories

CIRC-IT Scanner

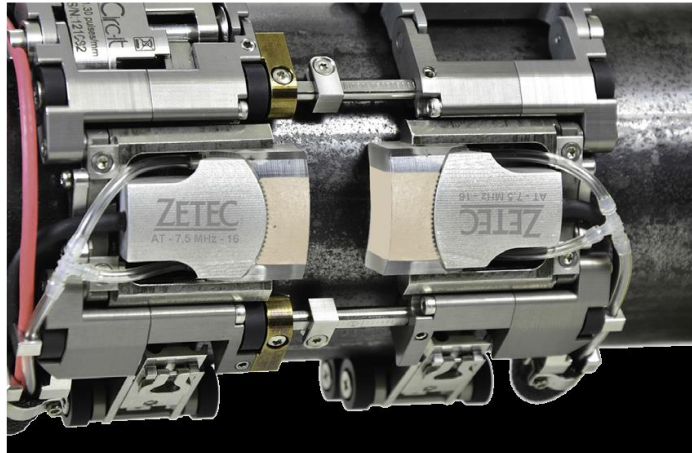

Circ-it is a manual small diameter scanner, designed to provide encoded position inspection of circumferential weld around piping and tubing from 21.4mm (0.840in) to 114.3mm (4.500in).

- **Low Profile Design:** Requires a radial clearance of 11mm (0.433in) which allows for inspection in limited access applications.
- **Urethane Wheels:** Durable urethane wheels provide smooth rolling and adequate traction in vertical scanning applications.
- **Cable Management:** Circ-it scanner features a cable management system for irrigation lines and probe cables.

Quick Change Links: Links provide infinite adjustment for pipes or tubes to be scanned between 21.4mm (0.840in) and 114.3mm (4.500in).

Ordering Information

Part Number	Short Description	Description
10040261	ZGN-SCN-CIRCT-IT	Manual Small Diameter Pipe Scanner - standard kit - low profile, can operate in an radial clearance of 0,433" envelope - lightweight, modular, easy to use - 1 encoder for circumferential scanning - compatible with pipe diameters from 0,840" to 4,500" - dual or single side applications.
10040262	ZGN-SCN-CIRCT-IT-SPARE-KIT1	Generic spare parts kit for Circ-It scanner - contains a variety of extra fasteners for the scanner, additional cable retention clips and sleeve for cable management, probe holder arm retention caps, crossbars, extra latches (short and long), links (short, medium, and long), and wheel blocks
10042727	ZGN-SCN-CIRCT-IT-ENCODER	Circ-it Scanner - Spare encoder
10049623	ZGN-SCN-CIRCT-IT-ENCODER-REPLACEMENT-KIT	DJG004-B - CIRC-IT ENCODER REPLACEMENT KIT, OMNISCAN MX / ZETEC

Note: See Probes & Wedges Section for compatible low-profile probes and accessories.

MPS (Manual Pipe Scanner)

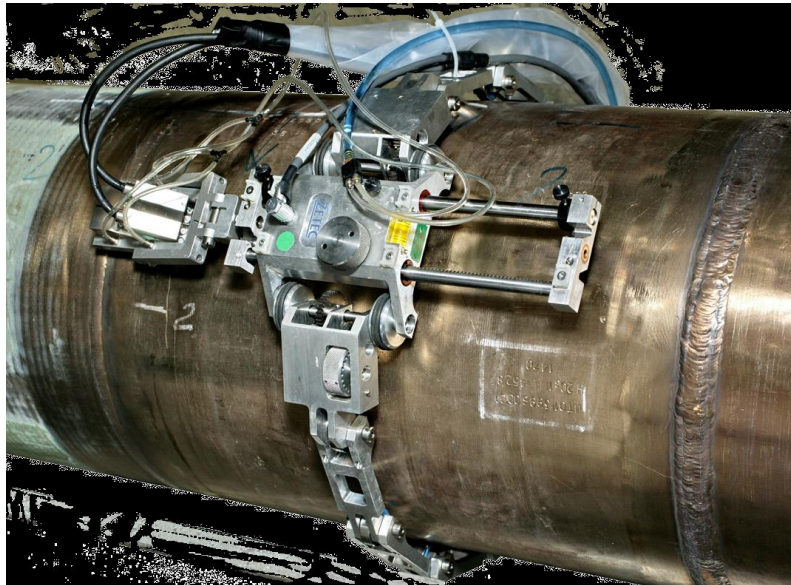

Manually driven, Semi, or Fully Automated Scanner: MPS scanners are available in 3 configurations: Manual (2 encoders for bidirectional scanning), Semi-manual (1 encoded motor on the circumferential axis and 1 manual encoder on axial axis), and Automated (2 encoded motors for bidirectional scanning)

Lightweight: The Manual Pipe Scanner weighs less than 7lbs (3.2 kg)

Quick and Easy Installation: Rapid installation by a single operator, no tools required

4" NPS and Up: Multiple link design, compatible with a wide range of pipe diameters

Inspection of Conical Geometries: Adjustable extension compatible with conical geometries

Ordering Information

Part Number	Short Description	Description
1372-00-0001	ZGN-SCN-MPS-KIT4-16IN	Manual Pipe Scanner - standard kit - lightweight, modular, easy to use - 2 encoders for bidirectional scanning - compatible with pipe diameters from 4" to 16"
10038653	ZGN-SCN-SMPS-KIT4-16IN	Semi-Manual Pipe Scanner - standard kit - lightweight, modular, easy to use - 1 encoded motor on circumferential axis, 1 manual encoder on axial axis, compatible with pipe diameters from 4" to 16"
10038652	ZGN-SCN-A-MPS-KIT4-16IN	Automated MPS - standard kit - lightweight, modular, easy to use - 2 encoded motors for bidirectional scanning - compatible with pipe diameters from 4" to 16", including 20ft cable for ZMC2 motion control unit or MCDU02 unit
10027221	ZGN-SCN-MPS-CIRC-MOT	Manual Pipe Scanner - dedicated motorized link for circumferential movement - can be controlled by MPSU-01
10024445	ZGN-SCN-MPS-TOFDLINK	Manual Pipe Scanner - dedicated carriage for TOFD inspections using one-line scanning
1372-70-0010	ZGN-SCN-MPS-XLL16-26IN	Manual Pipe Scanner - Extra Long Links Set - 16 to 26 inches
1372-70-0011	ZGN-SCN-MPS-XLL16-36IN	Manual Pipe Scanner - Extra Long Links Set - 16 to 36 inches
10024441	ZGN-SCN-MPS-ROD330MM	Manual Pipe Scanner - Long Translation Rod Set (330 mm)
10024442	ZGN-SCN-MPS-ROD200MM	Manual Pipe Scanner - Nominal Translation Rod Set (200 mm)
1372-70-0020	ZGN-SCN-MPS-ROD100MM	Manual Pipe Scanner - Short Translation Rod Set (100 mm)
1372-70-0021	ZGN-SCN-MPS-ROD0MM	Manual Pipe Scanner - Extra Short Translation Rod Set (0 mm) for one-line circumferential scanning - maximum width of scanner is less than 102 mm
1372-70-0030	ZGN-SCN-MPS-MAGWHEELS	Manual Pipe Scanner - Set of Six Magnetic Wheels - add on to actual wheels and allow the scanner to function on flat surface
1372-70-0035	ZGN-SCN-MPS-LASERHOLD	Manual Pipe Scanner - Laser Holder - for axial positioning
1372-70-0040	ZGN-SCN-MPS-EXT100MM	Manual Pipe Scanner - 100 mm Extension - increases the axial range and allow inspections on conical geometries (15 degrees)
10024443	ZGN-SCN-MPS-FIXT90DEG	Manual Pipe Scanner - 90 degree fixture - allows to mechanically skew the phased array probe by 90 degrees
10030493	ZGN-SCN-MPS-UNIVERSALFORK	Manual Pipe Scanner - Universal fork
10030737	ZGN-SCN-MPS-ENC	Manual Pipe Scanner - Spare encoder
1372-70-0050	ZGN-SCN-MPS-CBLDYNARAY	Manual Pipe Scanner - Encoder Cable - compatible with Z-Scan, Tomoscan III and DYNARAY systems
10024446	ZUT-SCN-MPS-SPARE-KIT1	Manual Pipe Scanner - Screw spare kit
10024447	ZUT-SCN-MPS-SPARE-KIT2	Manual Pipe Scanner - Ball plunger spare kit
10024448	ZUT-SCN-MPS-SPARE-KIT3	Manual Pipe Scanner - Gear spare kit
10024449	ZUT-SCN-MPS-SPARE-KIT4	Manual Pipe Scanner - Bearing spare kit
10024450	ZUT-SCN-MPS-SPARE-KIT5	Manual Pipe Scanner - O-Ring spare kit (10 units)

Probes & Wedges

A phased array probe consists of a series of piezo-electric elements, which can be independently excited. By precisely controlling the time delays between the excitation of the individual elements, ultrasonic beams of various angles, focal distance and beam shape can be generated and transmitted. The returning echo from a reflector is detected by the elements of the PA probe with slightly different times. The individual echo signals are then time-shifted before being summed up to reconstruct the A-scan signal.

Zetec offers several families of Phased Array probes designed for different type of inspection requirements. Standard phased array UT probes are offered in different sizes and frequencies to cover a wide spectrum of applications. Special care was put in their design to provide an ergonomic casing with captive screws for easy fixation on wedges or scanning mechanisms.

When used with Zetec's PA instruments, probes with ZPAC connectors are automatically detected by UltraVision thanks to the auto probe recognition function. All essential parameters are uploaded quickly and easily simplifying the setup creation process and minimizing the risk of errors.

Zetec also offers a complete line of wedges to complement its phased array UT probes. Designed to tackle many applications, wedges come equipped with irrigation channels and easy fixation points for simple interfacing with scanning mechanisms.

In addition to the Standard and Dedicated probe models, Zetec can provide the engineering services for design and manufacturing of custom phased array probes and wedges or minor modifications to standard probes and wedges.

Zetec has the expertise and experience to assist you determining the most appropriate transducers and wedges for your inspection.

Contact your local sales representative or visit us on www.zetec.com for more information.

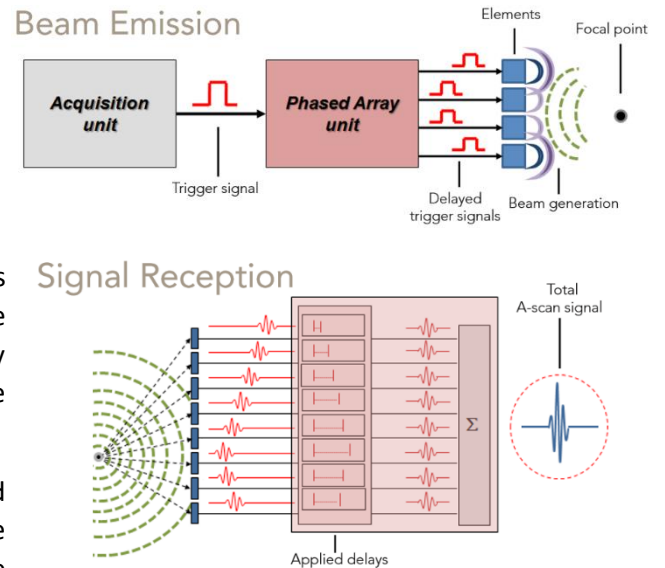

Ordering information

Probes

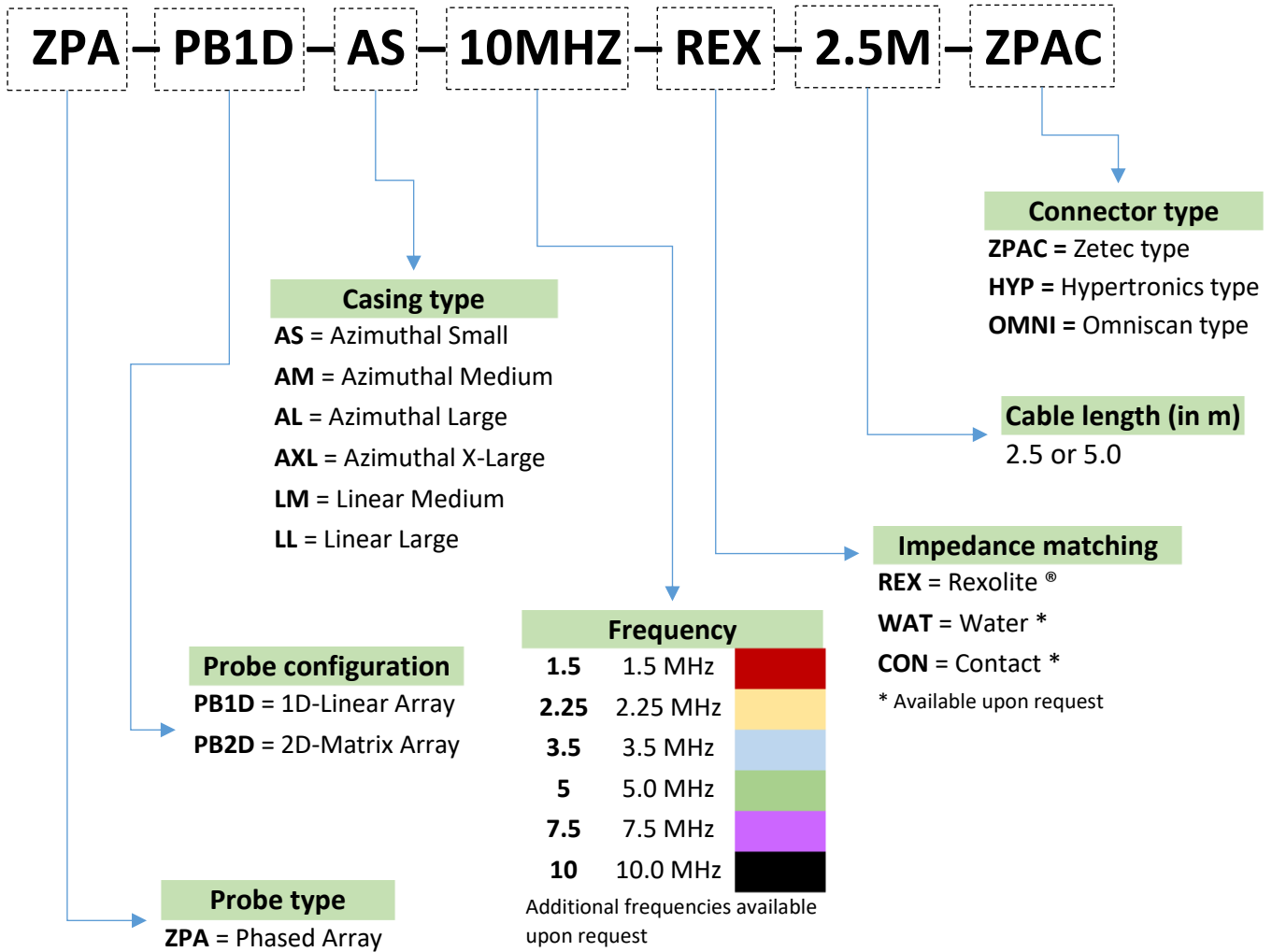

Wedges

ZPA – ACC – W – AM – 55SW – IH – FL

Probe casing type

AS = Azimuthal Small
AM = Azimuthal Medium
AL = Azimuthal Large
AXL = Azimuthal X-Large
LM = Linear Medium
LL = Linear Large

Contact surface

FL = Flat

ODX-CIRCFLAW = Curved wedge for X" pipe diameter. Circumferential inspection*

ODX-AXFLAW* = Curved wedge for X" pipe diameter. Axial inspection*

* X indicates the pipe external diameter in inches

Irrigation feature

IH = with irrigation channels

Nominal refracted angle in carbon steel and wave mode

LW = Longitudinal Wave (5920 m/s) / SW = Shear Wave (3230 m/s)

Standard = 0LW / 55LW / 55SW *

*Additional refracted angles available upon request

Probe Selection Guideline

Type	Zetec Portfolio	Probe Family	Generic Inspection / Welds	Deep penetration / Attenuative material	Restricted Access / Limited clearance	Corrosion / Paintbrush	Austenitic / Dissimilar Metal Welds	Time reversal / Flexible wedge (*)	High temperature (*)	Heavy forging / DGS (*)
1D-Linear	Standard	Linear / Azimuthal	✓	✓				✓		
		Extra-Thin (AT)			✓					
		Pitch / Catch				✓				
	Dedicated	Linear / Azimuthal		✓						
		Extra-Thin (AT)			✓					
		Linear Curved (*)						✓		
		High-Temp. (*)						✓		
2D-Matrix	Standard	Dual Matrix-Array					✓			
	Dedicated	Semi-Flexible (*)								✓

(*) New products – Coming soon – Stay tuned and visit us on www.zetec.com for more information

Standard Probes Portfolio

Standard 1D-Linear Probes

The standard 1D-Linear probes family cover the requirements for most typical weld and components integrity inspection configurations.

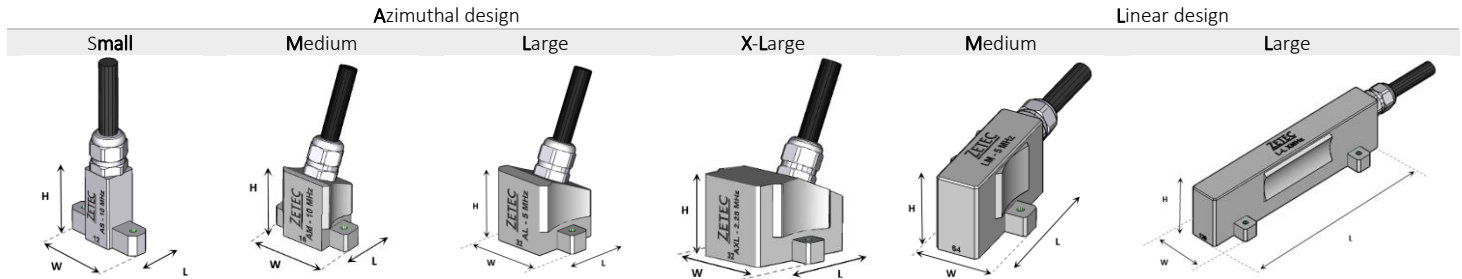

Type	Part Number	Acronym	Short description	Frequency (MHz)	Number of element	Primary aperture (mm)	Elevation (mm)	External dimensions (mm)			
								Length (L)	Width (W)	Height (H)	
AS Type	Probe	10045789	ZPA-PB1D-AS-10MHZ-REX-2.5M-ZPAC	AS-10MHZ	10.0	16	5.0	5.0	11.0	30.0	25.0
	Wedge	10038853	ZPA-ACC-W-AS-55SW-IH-FL	AS-55SW		N/A			16.3	30.0	10.2
		10038854	ZPA-ACC-W-AS-55LW-IH-FL	AS-55LW					17.2		16.9
AM Type	Probe	10045792	ZPA-PB1D-AM-5MHZ-REX-2.5M-ZPAC	AM-5MHZ	5.0	16	9.6	10.0	16.0	30.0	25.0
		10045793	ZPA-PB1D-AM-10MHZ-REX-2.5M-ZPAC	AM-10MHZ	10.0	32	9.9	10.0			
	Wedge	10038855	ZPA-ACC-W-AM-55SW-IH-FL	AM-55SW			N/A		23.5	30.0	12.5
		10038856	ZPA-ACC-W-AM-55LW-IH-FL	AM-55LW					25.0		23.3
AL Type	Probe	10045795	ZPA-PB1D-AL-5MHZ-REX-2.5M-ZPAC	AL-5MHZ	5.0	32	19.2	15.0	24.0	33.0	25.0
	Wedge	10038857	ZPA-ACC-W-AL-55SW-IH-FL	AL-55SW			N/A		38.2	33.0	22.0
		10038858	ZPA-ACC-W-AL-55LW-IH-FL	AL-55LW					41.4		41.2
AXL Type	Probe	10045797	ZPA-PB1D-AXL-2.25MHZ-REX-2.5M-ZPAC	AXL-2.25MHZ	2.25	32	32.0	20.0	36.0	38.0	25.0
	Wedge	10038859	ZPA-ACC-W-AXL-55SW-IH-FL	AXL-55SW			N/A		58.7	38.0	33.8
		10038860	ZPA-ACC-W-AXL-55LW-IH-FL	AL-55LW					62.4		65.6
LM Type		10045798	ZPA-PB1D-LM-2.25MHZ-REX-2.5M-ZPAC	LM-2.25MHZ	2.25						
	Probe	10045800	ZPA-PB1D-LM-5MHZ-REX-2.5M-ZPAC	LM-5MHZ	5.0	64	38.4	10.0	43.0	28.0	25.0
		10045801	ZPA-PB1D-LM-10MHZ-REX-2.5M-ZPAC	LM-10MHZ	10.0						
	Wedge	10038861	ZPA-ACC-W-LM-55SW-IH-FL	LM-55SW			N/A		63.8		34.2
		10038862	ZPA-ACC-W-LM-55LW-IH-FL	LM-55LW					57.7	28.0	40.0
10038863		ZPA-ACC-W-LM-0LW-IH-FL	LM-0LW					51.0		30.0	

All probes come with a standard cable length of 2.5 m (8.2 ft) with a TOPAZ / ZIRCON / QUARTZ compatible connector and an acoustic impedance matching layer for Rexolite®.

Other configurations (frequency, cable length and / or connector) are available upon request.

All Shear Waves (SW) and Longitudinal Waves (LW) wedges are designed for azimuthal scanning from 40 to 70 degree with a nominal refracted angle of 55° in Carbon Steel.

For your contoured wedge needs, please contact your local sales representative or see section Dedicated Contoured Wedges and Ordering information.

Probes Adapters

You can also use your own probe fleet with Zetec’s PA System (ZIRCON / TOPAZ / QUARTZ) by using the following probes connector adapters.

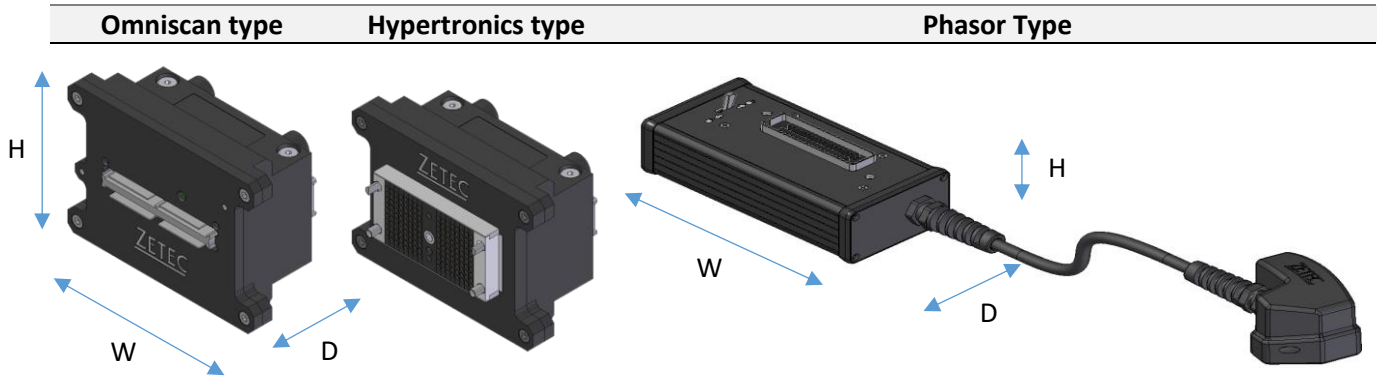

Probe Connector	Part Number	Acronym	External dimensions (mm)		
			Width (W)	Height (H)	Depth (D)
Omniscan type	10037251	ZPA-ACC-ADPBOX-ZPAC-OMNI	98.5	68.0	50.0
Hypertronics type	10037252	ZPA-ACC-ADPBOX-ZPAC-HYP	98.5	68.0	50.0
Phasor type	10041988	ZPA-ACC-ADPCBL-ZIRCON-PHAS	166.0	46.0	81.0

Standard 1D-Linear Low-profile Probes (extra-Thin) & Wedges

Low-profile phased array probes (AT) are optimized for the detection of small defects in thin-wall pipes.

Wedges are designed for a 60° Shear Wave nominal refracted angle in Carbon Steel (5920 m/s) and to cover from 0.5” up to 4” NPS.

Low-profile probes can operate with only 11.0 mm (0.433 in.) clearance.

Low-profile probes are offered in standard configuration with Dual probe heads 7.5 MHz (2 x 16 elements) on one ZPAC connector and 2.5 m cable length.

See Dedicated 1D-Linear Low-profile Probes for additional configurations.

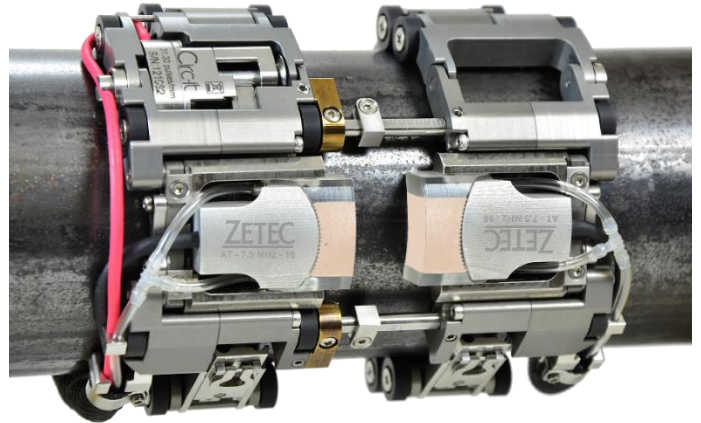

Type	Part Number	Acronym	Frequency (MHz)	Number of elements	Primary aperture (mm)	Elevation (mm)	External dimensions (mm)		
							Length (L)	Width (W)	Height (H)
Probe	10042357	ZPA-PB1D-AT-7.5MHZ-16-REX-2.5M-ZPAC-D	7.5	2x (16)	7.9	10	25.0	22.0	10.0
AT Type Wedges	10041895	ZPA-ACC-W-AT-60SW-IH-FL							
	10041896	ZPA-ACC-W-AT-60SW-IH-0.5NPS							
	10042470	ZPA-ACC-W-AT-60SW-IH-0.75NPS							
	10041897	ZPA-ACC-W-AT-60SW-IH-1NPS							
	10041898	ZPA-ACC-W-AT-60SW-IH-1.25NPS							
	10041899	ZPA-ACC-W-AT-60SW-IH-1.5NPS		N/A			16.2	22.0	< 11.0
	10041900	ZPA-ACC-W-AT-60SW-IH-2NPS							
	10041901	ZPA-ACC-W-AT-60SW-IH-2.5NPS							
	10041902	ZPA-ACC-W-AT-60SW-IH-3NPS							
	10041903	ZPA-ACC-W-AT-60SW-IH-3.5NPS							
10041904	ZPA-ACC-W-AT-60SW-IH-4NPS								

Note: the set of 11 AT-type wedges is also available in one kit 10042492 (Quantity x2 for each wedge) – see ordering information in the table below.

Part Number	Acronym	Note
10042492	ZPA-ACC-W-AT-KIT-0.5TO4NPS	kit contains 10 contoured pairs of wedges to cover OD from 0.5 to 4 in NPS and a pair of flat wedges

Corrosion Probes

Corrosion probes are offered in two different configurations: Pitch-catch and Pulse-echo techniques.

When using Pitch-catch, there is a considerable reduction of interface echo for optimum near surface resolution.



Configuration	Part Number	Acronym	Frequency (MHz)	Number of elements	Primary aperture (mm)	Elevation [mm]	External dimensions (mm)			
							Length (L)	Width (W)	Height (H)	
Pitch / Catch Large Aperture	Probe	10053850	ZPA-PB1D-TR-5M48x10-6.0-ZPAC-WM	5.0	2x (32)	48.0	2x (5.0)	65.5	25.4	24.4
	Probe-holder	10050956	ZPA-ACC-PTBR-PROBEHOLDER-01			N/A		74.1	35.2	15.0
Pitch / Catch Small Aperture	Probe	10053851	ZPA-PB1D-TR-5M24x10-6.0-ZPAC-WM	5.0	2x (32)	24.0	2x (5.0)	41.0	25.4	24.4
	Probe-holder	10052071	ZPA-ACC-PTBR-PROBEHOLDER-02			N/A		74.1	35.2	15.0
Pulse / Echo	Probe	10039141	ZPA-PB1D-LM-5MHZ-REX-5M-ZPAC	5.0	64	38.4	10.0	43.0	28.0	25.0
	Wedge	10050954	ZPA-ACC-W-LM-0LW-IH-PTBR-01			N/A		74.1		15.0

Standard 2D-Matrix Probes

The use of Transmit-Receive configurations yield better sensitivity and SNR. Compression waves are less affected by propagation through anisotropic materials than Shear waves.

With its 2D Dual Matrix Array probe family, Zetec offers a comprehensive solution for the inspection of coarse-grained, austenitic materials, corrosion-resistant alloys, and dissimilar metal welds, offering a superior signal-to-noise ratio.

The beam skewing capability of 2D Matrix Array probes improve the detection capability on mis-oriented flaws.

See Dedicated 2D-Matrix Probes for additional configurations.



	Part Number	Acronym	Frequency (MHz)	Number of elements	Primary aperture (mm)	Elevation (mm)	External dimensions (mm)		
							Length (L)	Width (W)	Height (H)
Probe	10053377	ZPA-PB2D-2.25M10X3E20-12-REX-3.0M-ZPAC-DUAL	2.25	2x (30)	19.8	11.8	30.0	16.0	20.0
Wedge	10053534	ZPA-ACC-W-TRL-23.0-4.0RF-FL-2.25M10x3E20-12					32.0	48.0	18.5
	10054148	ZPA-ACC-W-TRS-36.2-4.0RF-FL-2.25M10x3E20-12		N/A			40.0	48.0	25.0

Dedicated Probes Portfolio

Dedicated 1D-Linear Probes

Type	Part Number	Acronym	Frequency (MHz)	Number of element	Primary aperture (mm)	Elevation (mm)	External dimensions (mm)			
							Length (L)	Width (W)	Height (H)	
AS Type	Probe	10045787	ZPA-PB1D-AS-5MHZ-REX-2.5M-ZPAC	5.0	12	7.2	7.2	11.0	30.0	25.0
		10045788	ZPA-PB1D-AS-7.5MHZ-REX-2.5M-ZPAC	7.5	12	7.2	7.2	11.0	30.0	25.0
	Wedge	10038853	ZPA-ACC-W-AS-55SW-IH-FL					16.3	30.0	10.2
		10038854	ZPA-ACC-W-AS-55LW-IH-FL			N/A		17.2	30.0	16.9
AM Type	Probe	10045790	ZPA-PB1D-AM-2.25MHZ-REX-2.5M-ZPAC	2.25	16	12	12	16.0	30.0	25.0
		10045791	ZPA-PB1D-AM-3.5MHZ-REX-2.5M-ZPAC	3.5	16	9.6	10.0			
	Wedge	10038855	ZPA-ACC-W-AM-55SW-IH-FL					23.5		12.5
		10038856	ZPA-ACC-W-AM-55LW-IH-FL			N/A		25.0	30.0	23.3
AL Type	Probe	10045794	ZPA-PB1D-AL-3.5MHZ-REX-2.5M-ZPAC	3.5	32	19.2	15.0	24.0	33.0	25.0
	Wedge	10038857	ZPA-ACC-W-AL-55SW-IH-FL					38.2		22.0
		10038858	ZPA-ACC-W-AL-55LW-IH-FL					41.4	33.0	41.2
AXL Type	Probe	10045796	ZPA-PB1D-AXL-1.5MHZ-REX-2.5M-ZPAC	1.5	32	32.0	20.0	36.0	38.0	25.0
	Wedge	10038859	ZPA-ACC-W-AXL-55SW-IH-FL					58.7		33.8
		10038860	ZPA-ACC-W-AXL-55LW-IH-FL			N/A		62.4	38.0	65.6
LM Type	Probe	10045799	ZPA-PB1D-LM-3.5MHZ-REX-2.5M-ZPAC	3.5	64	38.4	10.0	43.0	28.0	25.0
	Wedge	10038861	ZPA-ACC-W-LM-55SW-IH-FL					63.8		34.2
		10038862	ZPA-ACC-W-LM-55LW-IH-FL			N/A		57.7	28.0	40.0
		10038863	ZPA-ACC-W-LM-0LW-IH-FL					51.0		30.0
LL Type	Probe	10045802	ZPA-PB1D-LL-2.25MHZ-REX-2.5M-ZPAC	2.25						
		10045803	ZPA-PB1D-LL-3.5MHZ-REX-2.5M-ZPAC	3.5						
		10045804	ZPA-PB1D-LL-5MHZ-REX-2.5M-ZPAC	5.0	128	96.0	10.0	100.0	28.0	25.0
		10045805	ZPA-PB1D-LL-10MHZ-REX-2.5M-ZPAC	10.0						
	Wedge	10038864	ZPA-ACC-W-LL-55SW-IH-FL					141.2		71.7
		10038865	ZPA-ACC-W-LL-55LW-IH-FL			N/A		120.6	28.0	63.9
10038866		ZPA-ACC-W-LL-0LW-IH-FL					110.0		50.0	

Dedicated Contoured Wedges

Although all wedges listed are designed for flat specimens, you can ask for custom contouring of the contact surface for cylinder shape parts – See Ordering information for Wedges

Please contact your local sales representative or see Ordering information for Wedges.

Circumferential flaw detection - CIRCFLAW

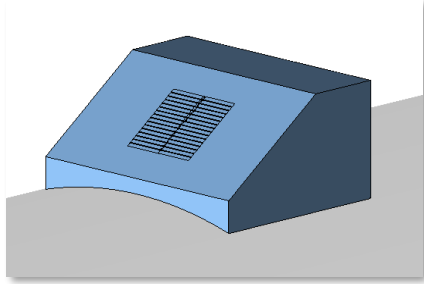

Wedges are contoured **along the elevation of the probe**

Axial flaw detection - AXFLAW

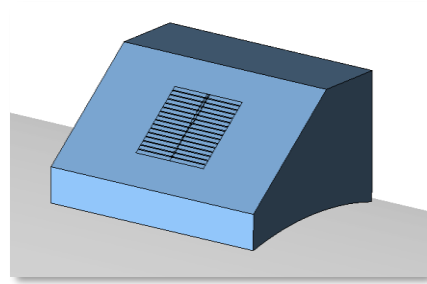

Wedges are contoured **along the probe primary axis**

Dedicated 1D-Linear Low-Profile Probes

The “extra-Thin” probes are also available in single configuration (one probe head) with either 16 or 32 elements in 3 frequencies 5.0, 7.5 and 10.0 MHz.

Configuration	Part Number	Acronym	Frequency (MHz)	Number of element	Primary aperture (mm)		External dimensions (mm)		
					Elevation (mm)	Length (L)	Width (W)	Height (H)	
Single head	10041890	ZPA-PB1D-AT-5MHZ-16-REX-2.5M-ZPAC	5.0	16	7.9	10	25.0	22.0	10.0
	10041891	ZPA-PB1D-AT-7.5MHZ-16-REX-2.5M-ZPAC	7.5						
	10041893	ZPA-PB1D-AT-10MHZ-16-REX-2.5M-ZPAC	10.0						
	10041892	ZPA-PB1D-AT-7.5MHZ-32-REX-2.5M-ZPAC	7.5	32					
	10041894	ZPA-PB1D-AT-10MHZ-32-REX-2.5M-ZPAC	10						
Dual heads	10042356	ZPA-PB1D-AT-5MHZ-16-REX-2.5M-ZPAC-D	5.0	16	7.9	10	25.0	22.0	10.0
	10042359	ZPA-PB1D-AT-10MHZ-16-REX-2.5M-ZIRCON-D	10.0						
	10042358	ZPA-PB1D-AT-7.5MHZ-32-REX-2.5M-ZPAC-D	7.5	32					
	10042360	ZPA-PB1D-AT-10MHZ-32-REX-2.5M-ZIRCON-D	10.0						

Dedicated 2D-Matrix Probes

The 2D-Matrix Probes are also proposed with the following configurations (1.5 and 3.5 MHz) for specific inspection needs.

Please contact your local sales representative for additional information.

	Part Number	Acronym	Frequency (MHz)	Number of elements	Primary aperture (mm)	Elevation (mm)	External dimensions (mm)		
							Length (L)	Width (W)	Height (H)
Probe	10052832	ZPA-PB2D-1.5M8X4E20-12-REX-3.0M-ZPAC-DUAL	1.5	2x (32)	19.8	11.8	30.0	16.0	20.0
Wedge	10053813	ZPA-ACC-W-TRL-23.0-4.0RF-FL-1.5M8x4E20-12			N/A		32.0	48.0	18.5
	10054144	ZPA-ACC-W-TRS-36.2-4.0RF-FL-1.5M8x4E20-12					40.0	48.0	25.0
Probe	10053438	ZPA-PB2D-1.5M8x4E28-16-REX-3.0M-ZPAC-DUAL	1.5	2x (32)	27.8	15.8	39.0	20.0	25.0
Wedge	10054146	ZPA-ACC-W-TRL-23.0-4.0RF-FL-1.5M8x4E28-16			N/A		40.0	56.0	22.5
	10054147	ZPA-ACC-W-TRS-36.2-4.0RF-FL-1.5M8x4E28-16					48.0	56.0	30.0
Probe	10053440	ZPA-PB2D-3.5M16X2E20-12-REX-3.0M-ZPAC-DUAL	3.5	2x (32)	19.8	11.8	30.0	16.0	20.0
Wedge	10053814	ZPA-ACC-W-TRL-23.0-4.0RF-FL-3.5M16x2E20-12			N/A		32.0	48.0	18.5
	10054149	ZPA-ACC-W-TRS-36.2-8.0RF-FL-3.5M16x2E20-12					40.0	48.0	25.0

Custom Probes

In addition to the standard probe models, Zetec can provide engineering and consulting services for the design and manufacturing of custom phased array probes and wedges.

Regardless of the application, Zetec can provide you the probes and wedges you need:

- 1D Linear and 2D Matrix arrays
- Dual configuration of 1D Linear and 2D Matrix arrays
- Low-frequency probes
- Special wedges

Please contact your local sales representative for more information about Custom PA Probes.

TOFD Probes, Wedges & Accessories

Zetec also offers conventional UT TOFD transducers in 3 crystal diameter sizes (\varnothing 3.0, \varnothing 6.0 and \varnothing 12.0 mm) and 5 center frequencies (from 2 MHz to 15 MHz). This standard product line is specifically designed for TOFD applications.

The TOFD transducers are provided with a generic technical datasheet and a Certification Of Conformity whose parameters are specified in accordance with BSEN 12668 pt2: 2010.

The measurement report of the individual parameters is not included and shall be ordered with the additional ZETEC Reference 10054725 (one per transducer).

Other configurations (frequency, cable length and / or connector) are available upon request.

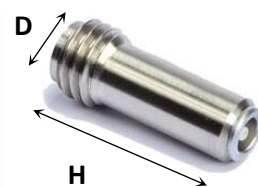

Type	Part Numbers	Acronym	Frequency (MHz)	Crystal diameter (mm)	Short description	Thread type	Connector	External dimensions (mm)		
								Diam. (D) Width (W)	Height (H) Length (L)	
Transducer (D x L)	10042086	ZUT-PB-PIEZO-TOFD2-6-LEMO00	2.0	6.0	TOFD2-6	M12	LEMO 00	10.0	30.0	
	10042061	ZUT-PB-PIEZO-TOFD2-12-LEMO00		12.0	TOFD2-12	M20		17.0		
	10039845	ZUT-PB-PIEZO-TOFD5-3-LEMO00	5.0	3.0	TOFD5-3	M12		10.0		
	10038328	ZUT-PB-PIEZO-TOFD5-6-LEMO00		6.0	TOFD5-6					
	10039846	ZUT-PB-PIEZO-TOFD7.5-3-LEMO00	7.5	3.0	TOFD7.5-3					
	10039847	ZUT-PB-PIEZO-TOFD7.5-6-LEMO00		6.0	TOFD7.5-6					
	10039848	ZUT-PB-PIEZO-TOFD10-3-LEMO00	10.0	3.0	TOFD10-3					
	10039849	ZUT-PB-PIEZO-TOFD10-6-LEMO00		6.0	TOFD10-6					
	10039850	ZUT-PB-PIEZO-TOFD15-3-LEMO00	15.0	3.0	TOFD15-3					
Wedges (W x L)	10038329	ZUT-ACC-WEDGE-TOFD-45LW-M12-IRR	N/A		TOFD-45LW-M12		N/A		30.0	20.0
	10038330	ZUT-W-TOFD-60LW-M12-IH-FL			TOFD-60LW-M12					
	10038331	ZUT-W-TOFD-70LW-M12-IH-FL			TOFD-70LW-M12					
	10042062	ZUT-ACC-WEDGE-TOFD-30LW-M20-IRR			TOFD-30LW-M20					
	10036027	ZUT-ACC-WEDGE-TOFD-45LW-M20-IRR			TOFD-45LW-M20					
	10036028	ZUT-ACC-WEDGE-TOFD-60LW-M20-IRR			TOFD-60LW-M20					
Cables	10038332	ZUT-ACC-CBL-LEMO-LEMO-2M			CBL-LEMO-LEMO-2M		N/A			
	10039746	ZUT-ACC-CBL-LEMO-LEMO-DOUBLE-5M			CBL-LEMO-LEMO-5M					
	10054725	ZUT-PB-PIEZO-TOFD-CERT-IP	Certificate (individual parameters of the specific TOFD transducer recorded)							

Glossary

Frequency: Theoretical central frequency of the ultrasonic pulse generated by your probe.

Primary Axis: Axis along which the individual elements are aligned for 1D linear probe

Secondary Axis / Elevation : Axis perpendicular to the primary axis of a probe

Number of Elements (Primary Axis): Total number of elements aligned along the primary axis

Number of Elements (Secondary Axis): Total number of elements aligned along the secondary axis (2D Matrix Array only)

Primary Axis Pitch: Center-to-center distance between two consecutive elements along the primary axis

Secondary Axis Pitch: Center-to-center distance between two consecutive elements along the secondary axis (2D Matrix Array only)

Primary Axis Aperture: Dimension of the probe surface along the primary axis

Secondary Axis Aperture: Dimension of the probe surface along the secondary axis

Active Aperture: Group of elements effectively used for the generation and reception of an ultrasonic beam

Near Field Length: Distance along the beam axis from the probe surface to the position where the maximum sound field intensity is reached

Maximum Sound Field Depth: Depth at which the maximum sound field intensity on the beam axis is reached

Focal Zone Length: Distance along the beam axis between the positions before and beyond the focal point (maximum intensity) where the sound field intensity is reduced by 6 dB

Wedge Angle: Angle between the primary axis of the probe and the flat projection of the specimen surface along the mechanical axis (scan or index)

Height at the Middle of the First Element (H1): Height of the first element of the probe when placed on a wedge

Primary Axis Offset at the Middle of the First Element (X1): Position along the primary axis of the first element of the probe from the wedge reference

Secondary Axis Offset at the Middle of the First Element (Y1): Position along the secondary axis of the first element of the probe from the wedge reference

Eddy Current Table of Contents

ECT Systems Ordering Information..... 77

Eddy Current Instruments 79

Eddy Current Probe Delivery 97

Eddy Current Software Solutions..... 117

Eddy Current Probes Table of Contents 126

ECT Systems Ordering Information

Zetec ECT Systems is transitioning to smart part numbers and descriptions to make it easier to understand quotes and orders. Note that Zetec Probes follow a different format.

Smart Part Numbers

XXXYRRR-ZZ-D

Where

- XXXY is the project number, where XXX are digits and Y is a letter;
- RRR is the assembly number;
- ZZ is the part index number;
- D is the dash number, if applicable.

Project numbers started with 001A and increase sequentially in time to 999A. After 999A, the project number will roll to 001B. The top-level assembly number for any project is comprised of all zeros.

Sub-assemblies cascade from top level number in a hierarchical format, with each digit to the right representing a lower level sub-assembly. For example:

- 001A000-00 is the top-level assembly for the project;
- 001A100-00 is a major sub-assembly within 001A000-00;
- 001A100-01 is a part in 001A100-00.

Smart Part Descriptions

Sales parts will adhere to the following the smart part description naming convention, when applicable.

Z□₁ - □₂ - □₃ - □₄

□ ₁	Type Description
EC	Eddy Current
ES	Eddy Current Surface
PA	Phased Array
UT	Ultrasonic
GN	Generic Product

□ ₂	Family Description
ACC	Accessory
ADP	Adapter Cable
CAL	Calibration
CTR	Controller
EXT	Extension Cable
HHT	Hand Held Tester
HRN	Harness Cable
PSH	Probe Pusher
RDT	RDAU Tester
ROB	Robot
SCN	Mechanical Scanner
SP	Spare Part
SRV	Service
SWS	Software Product
TRN	Training
UIT	User Interface Tester
OTR	Other

□ ₃	Model Description
----------------	-------------------

□ ₄	Unique Description
----------------	--------------------

Spare Part Categories

Zetec has a tiered methodology to the availability of spare parts based on the following categories:

Tier 1: available to all owners

Tier 2: available to owners who are Zetec trained or use Zetec for maintenance

Eddy Current Instruments

MIZ[®]-200



Characteristics

When performance matters

The MIZ[®]-200 portable eddy current instrument for tubing and surface inspections is the latest innovation from Zetec. It has been specifically designed for balance-of-plant (BOP) / power generation and oil & gas applications. Developed for demanding inspection environments, the MIZ-200 provides enhanced capability in a compact, rugged, and sealed unit.

Rugged and portable

The MIZ-200 is as tough as the inspection environment, but easy on your back with its lightweight and portable size. It is compact and lightweight yet rugged and dependable. The MIZ-200 is conveniently powered from either AC mains or hot swappable lithium-ion rechargeable batteries.

The rugged cast aluminum case is designed to withstand the bumps and drops that inevitably happen in inspection environments, and the sealed and fanless unit will withstand dust and water. The rubber corner bumpers serve as convenient handles. They are easily gripped with a bare or gloved hand. Each corner also has integrated carry pins that can be used to affix a shoulder strap or carry handle.

Enhanced capability

The MIZ-200 boasts improvements over competitive products and includes new features in one highly capable eddy current instrument.

- Large Surface Array Coil Capacity
- Improved Signal Processing
- Built-in Probe Pusher Control
- Support for a Wide Range of Probes

Product evolution. Technology innovation.

Borrowing from our best in class products the MIZ-200 is our latest and best foot forward. The MIZ-200 incorporates the latest technology along with the best features of the MIZ-85 and ZIRCON instruments. Velocity Software complements the instrument to create the most effective solution.

Proven on ZIRCON

- Enclosure
- Batteries and battery charging
- CPU board
- AC-to-DC power adapter

Proven on MIZ-85

- MRPC
- Encoders
- Amplifiers for French probes
- Current source for French probes
- Pusher control

Specifications

FEATURE	GENERAL
Dimensions (W x H x D)	11.7 × 4.2 × 12.8 in (29.7 × 10.7 × 32.5 cm)
Weight	14.7 lbs. (6.7 kg) w/ batteries. 12.7 lbs. (5.8 kg) without batteries.
Battery	8 hrs (typical), hot swappable
Battery Type	Lithium-ion rechargeable
Power	115/230 VAC and self-switching
Computer Interface	LAN 10 / 1000 Base T
Phased Array Channels	32/128 P or 32/128 PR
Operating Temperature	23°F to 113°F (-5°C to 45°C)
Storage Temperature	-4°F to 140°F (-20°C to 60°C)

FEATURE	EDDY CURRENT (ECT)
Probe Inputs	8
Number of frequencies	Up to 160
Frequency range	5 Hz – 4 MHz
Generators	2
Power	3 (1 is for French probes only)
Generator output	Up to 20 Volts peak-to-peak
Injection modes	Continuous and Super-Multiplex
Receiver gain	23 – 58 dB, 35 dB range
ADC resolution	16 bits
Acquisition/sampling rate	Up to 40,000 per second
Connector	36-pin circular for X-probes and MRPC probes 4-pin for bobbin with adapter #10038239 6-pin for French with adapter #009A801-00 Two 4-pin for AC3 with adapter #009A802-00 8-pin for MFL with adapter #009A804-00

FEATURE	EDDY CURRENT ARRAY (ECA)
Probe Inputs	128
Probe Outputs	128
Number of frequencies	Up to 160
Frequency range	5 Hz – 4 MHz
Generator/ Coil driver	2
Generator output	Up to 20 Volts peak-to-peak
Injection modes	Continuous and Super-Multiplex
Receiver gain	23 – 58 dB, 35 dB range
ADC resolution	16 bits
Acquisition/sampling rate	Up to 40,000 per second
Multiplexer	Internal, configures MIZ200 to match the probe coil arrangement (differential, absolute, driver-pickup, transmit-receive, differential driver-pickup)
Connector	160-pin rectangular

FEATURE	LOW-VOLTAGE REMOTE FIELD TESTING (RFT)
---------	--

Probe Inputs	4
Number of frequencies	5
Frequency range	5 Hz – 250 KHz
Generator/ Coil driver	2
Generator output	Up to 20 Volts peak-to-peak
Injection modes	Continuous
Receiver gain	36 – 86 dB, 50 dB range
ADC resolution	16 bits
Acquisition/sampling rate	Up to 40,000 per second
Connector	19-pin circular

FEATURE	MAGNETIC FLUX LEAKAGE (MFL)
Probe Inputs	4
Receiver gain	20 – 58 dB, 38 dB range
ADC resolution	16 bits
Acquisition/sampling rate	Up to 40,000 per second
Connector	36-pin circular, 8-pin with adapter #009A804-00

FEATURE	MOTOR DRIVE FOR MRPC PROBES
Speed regulation	Regulation of probe rotating speed to provide constant speed under varying loads
Output Current	2.7A continuous
Maximum Power	35 Watts continuous
Connector	36-pin circular

Ordering Information

Part Number	Description	Details
10048495	ZES-RDT-MIZ-200-TUBING	<p>MIZ-200 Eddy Current Test Instrument Tubing – ECT, RFT, NFT, AC3, French</p> <p>Includes:</p> <ul style="list-style-type: none"> • MIZ-200 Instrument • 36-Pin to 4-Pin Bobbin Adapter • AC/DC Power Adapter • Filtered Power Cord • User Manual • Carry Handle • RJ45 Cat-5e Ethernet Cable • Shipping Case • Velocity Software Install CD • Velocity AQ Key • 1 Year Warranty
10051666	ZES-RDT-MIZ-200-TUBING + MFL	<p>MIZ-200 Eddy Current Test Instrument Tubing – ECT, RFT, NFT, AC3, French, MFL</p> <p>Includes:</p> <ul style="list-style-type: none"> • MIZ-200 Instrument • 36-Pin to 4-Pin Bobbin Adapter • AC/DC Power Adapter • Filtered Power Cord • User Manual • Carry Handle • RJ45 Cat-5e Ethernet Cable • Shipping Case • Velocity Software Install CD • Velocity AQ Key • 1 Year Warranty
10048500	ZES-RDT-MIZ-200-ARRAY 64	<p>MIZ-200 Eddy Current Test Instrument Tubing and Array 64 – ECT, RFT, NFT, AC3, French</p> <p>Includes:</p> <ul style="list-style-type: none"> • MIZ-200 Instrument • 36-Pin to 4-Pin Bobbin Adapter • AC/DC Power Adapter • Filtered Power Cord • User Manual • Carry Handle • RJ45 Cat-5e Ethernet Cable • Shipping Case • Velocity Software Install CD • Velocity AQ Key • 1 Year Warranty
10050200	ZES-RDT-MIZ-200-ARRAY 64 + MFL	<p>MIZ-200 Eddy Current Test Instrument Tubing and Array 64 – ECT, RFT, NFT, AC3, French, MFL</p> <p>Includes:</p> <ul style="list-style-type: none"> • MIZ-200 Instrument • 36-Pin to 4-Pin Bobbin Adapter • AC/DC Power Adapter • Filtered Power Cord • User Manual • Carry Handle

		<ul style="list-style-type: none"> • RJ45 Cat-5e Ethernet Cable • Shipping Case • Velocity Software Install CD • Velocity AQ Key • 1 Year Warranty
10048501	ZES-RDT-MIZ-200-ARRAY 128	<p>MIZ-200 Eddy Current Test Instrument Tubing and Array 128 – ECT, RFT, NFT, AC3, French Includes:</p> <ul style="list-style-type: none"> • MIZ-200 Instrument • 36-Pin to 4-Pin Bobbin Adapter • AC/DC Power Adapter • Filtered Power Cord • User Manual • Carry Handle • RJ45 Cat-5e Ethernet Cable • Shipping Case • Velocity Software Install CD • Velocity AQ Key • 1 Year Warranty
10050201	ZES-RDT-MIZ-200-ARRAY 128 + MFL	<p>MIZ-200 Eddy Current Test Instrument Tubing and Array 128 – ECT, RFT, NFT, AC3, French, MFL Includes:</p> <ul style="list-style-type: none"> • MIZ-200 Instrument • 36-Pin to 4-Pin Bobbin Adapter • AC/DC Power Adapter • Filtered Power Cord • User Manual • Carry Handle • RJ45 Cat-5e Ethernet Cable • Shipping Case • Velocity Software Install CD • Velocity AQ Key • 1 Year Warranty

Software Options

Part Number	Description	Details
10047951	ZES-SWS-PC-VELOCITY/ AN_V1.x_CO	Includes: <ul style="list-style-type: none"> • Velocity Analysis (AN) • 1year SSP
10048849	ZES-SWS-PC-VELOCITY/ AN_V1.x_KEY_CO	Includes: <ul style="list-style-type: none"> • Velocity Analysis (AN) • USB Key • 1year SSP
10049901	ZES-SWS-PC-VELOCITY/ AN+CSCAN_V1.x_CO	Includes: <ul style="list-style-type: none"> • Velocity Analysis (AN) + Advanced C-Scan • 1year SSP
10049900	ZES-SWS-PC-VELOCITY/ AN+CSCAN_V1.x_KEY_CO	Includes: <ul style="list-style-type: none"> • Velocity Analysis (AN) + Advanced C-Scan • USB Key • 1year SSP
10047952	ZES-SWS-PC-VELOCITY/ DM_V1.x_CO	Includes: <ul style="list-style-type: none"> • Velocity Data Management (DM) • 1year SSP
10048850	ZES-SWS-PC-VELOCITY/ DM_V1.x_KEY_CO	Includes: <ul style="list-style-type: none"> • Velocity Data Management (DM) • USB Key • 1year SSP
10052906	ZES-SWS-PC-VELOCITY/ BUNDLE_V1.x_CO	Includes: <ul style="list-style-type: none"> • Velocity Analysis (AN) • Velocity Data Management (DM) • 1year SSP
10048851	ZES-SWS-PC-VELOCITY/ BUNDLE_V1.x_KEY_CO	Includes: <ul style="list-style-type: none"> • Velocity Analysis (AN) • Velocity Data Management (DM) • USB Key • 1year SSP

Adapters – Tier 1

Part Number	Description	Details
10038239	ZEC-ADP-MIZ_36-PIN_TO_4-PIN_SOLID	Used for 4-Pin Bobbin probes. This is a short rigid adapter. Works on MIZ-80, MIZ-85, and MIZ-200.
10022045	ZEC-ADP-MIZ_36-PIN_TO_4-PIN_FLEX_6IN	This is the same adapter as 10038239 used for 4-Pin Bobbin probes, but it has a flexible 6" cable. Works on MIZ-80, MIZ-85, and MIZ-200.
009A801-00	ZEC-ADP-MIZ-200_36-PIN_TO_6-PIN_SAX_PROBE	Used for 6-Pin SAX probes. Only works on MIZ-200.
009A802-00	ZEC-ADP-MIZ_36-PIN_TO_DUAL_4-PIN_AC3	Used for dual 4-Pin AC3 probes. Works on MIZ-80, MIZ-85, and MIZ-200.
009A804-00	ZEC-ADP-MIZ-200_36-PIN_TO_8-PIN_MFL	Used for 8-Pin MFL probes. Only works on MIZ-200.
009A808-00	ZEC-ADP-MIZ-200_36-PIN_TO_12-PIN_HV_RFT	Used for 12-Pin High Voltage RFT. Only works on MIZ-200.
009A811-00	ZEC-ADP-MIZ_36-PIN_TO_41-PIN_BOBBIN	Used for MS5800 41-Pin Bobbin probes. Works on MIZ-80, MIZ-85, and MIZ-200.
10041339	ZEC-ADP-MIZ_36-PIN_TO_36-PIN_RG3-4	Used for RG3-4 probes. Works on MIZ-80, MIZ-85, and MIZ-200.
10022316	ZEC-ADP-MIZ_36-PIN_TO_10-PIN_MRPC_AND_5-PIN_MU_10IN	Used for 10-Pin/5-Pin MRPC probes (Supports 1 to 3 coils). Also used in China. Works on MIZ-80, MIZ-85, and MIZ-200.

Accessories and Spare Parts – Tier 2

Part Number	Description	Details
009A000-01	BLACK BUMPER	Tier 2
009A100-01	MIZ-200, CASE BOTTOM	Tier 2
009A120-00	FAN ASSY	Tier 2
009A130-00	PCBA, MIZ-200 ACQUISITION	Tier 2
009A140-00	PCBA, MIZ-200 POWER SUPPLY	Tier 2
009A160-00	PCBA, MIZ-200 DPU	Tier 2
009A200-02	MIZ-200, SHELL TOP	Tier 2
009A210-00	MIZ-200 POWER WIRING ASSY	Tier 2
10037645	1-WIRE ASSEMBLY	Tier 2

MIZ[®]-21C

The Most Advanced Handheld With Surface Array Capability

TRULY AFFORDABLE EDDY CURRENT



Introducing MIZ®-21C, the most advanced handheld instrument with surface array capabilities. The truly affordable MIZ-21C is ideal for aerospace, oil & gas, manufacturing and power generation applications. Its ergonomic design, long battery life and intuitive touchscreen mean you can inspect more areas faster than ever without fatigue. The MIZ-21C is compatible with a wide range of probes and scanners and comes in three models to meet your unique inspection needs and budget.

Designed for a Wide Range of Applications.

MIZ-21C delivers an inspection advantage across numerous inspection applications including:

Detecting Cracks Near Fastener Holes. Pencil probes are ideal for detecting small cracks in close proximity to fastener holes. The inspector uses a known crack or notch standard to set up the MIZ-21C signal display. Then, while scanning the test piece, the inspector can estimate the depth and length of surface cracks by comparing the phase and amplitude of the generated eddy current signal to the standard's signal.

Multi-Layer Corrosion Inspection. Identifying corrosion is one of the most critical and complex aspects of airframe inspections. Changes in skin thickness as well as varying multi-layer structures usually make it difficult to recognize signals. The MIZ-21C has the power to penetrate thick sections. Exceptional signal-to-noise ratio helps inspectors distinguish even a small loss of material. Dual-frequency with mixing nearly eliminates the unwanted signals caused by varying air gaps between layers that can "mask" the signal of interest.

Conductivity and Coating Thickness Measurement. Use digital conductivity measurements (resistivity) to characterize/sort materials. Directly measure the conductivity of metals and alloys, such as aluminum structures, using dedicated conductivity probes that have a broad operating frequency range. Or measure a nonconductive coating such as paint. The MIZ-21C offers a wide measurement range for both conductivity and thickness.

Save Time & Money.

MIZ-21C is a fast, highly portable and cost-effective replacement for Liquid Penetrant Testing (PT) and Magnetic Particle Testing (MT) inspections. The surface array option can reduce inspection time by up to 95% versus pencil probes. MIZ-21C's intuitive touchscreen and simple, yet powerful embedded software gets users inspecting in no time, offering quick set-up and hassle-free operation.

Inspect More Areas.

The MIZ-21C is designed for user comfort. It can be held for twice as long as other Eddy Current portable devices. The small form factor enables users to inspect hard-to-reach areas and components that other instruments can't. MIZ-21C brings the power of surface array to places it has never been before.

Improve Flaw Detection.

MIZ-21C features an industry-leading signal quality providing up to 25% better flaw detection capability. When coupled with surface array, users can be confident that MIZ-21C will deliver the most thorough inspection in its class.

Specifications in this document are subject to change

FEATURE	
Size (H × W × D)	267 × 122 × 38 mm (10.5 × 4.8 × 1.5 in)
Weight (including batteries and cover)	1.22 kg (2.7 lb)
Multi-Touch Display	5.7 in (480 x 640 pixels)
Battery Life	8 hr per charge
Eddy Current Connector	18-Pin Lemo
Eddy Current Array Connector	26-Pin Lemo
Connectivity	USB 2.0, Wi-Fi, Bluetooth
Encoders	2 axes, quadrature
Probe Recognition and Setup	Automatic, Zetec Coil ID Chip
Coil Inputs	MIZ-21C-SF: 1, MIZ-21C: 1, MIZ-21C-ARRAY: 3
Frequencies Per Timeslot	MIZ-21C-SF: 1, MIZ-21C: 2, MIZ-21C-ARRAY: 2
Data Channels	MIZ-21C-SF: 32, MIZ-21C: 64, MIZ-21C-ARRAY: 192
Maximum Probe Coils	MIZ-21C-SF: 2, MIZ-21C: 2, MIZ-21C-ARRAY: 32
Frequency Range	5 Hz to 10 MHz
Generator Output	Up to 19 Vpp
Injection Modes	Continuous and Super-Multiplex
Receiver Gain	10 – 53 dB, 43 dB range
Data Resolution	16 bits
Acquisition / Sampling Rate	Up to 25,000 per second
Probe Drive	50 Ohm
Filters	Adjustable CC, Median, High Pass, Low Pass, Bandpass, Spike
Alarms	Adjustable Box, Audio adjustable volume, Headphone support
Conductivity Frequency	60, 120, 240 and 480 kHz
Conductivity Specification	Digital readout in 0.9 to 110 %IACS (0.5 to 70 MS/m), Accuracy within ±0.5% IACS from 0.9% to 65% IACS and within ±1.0% of values over 65%
Non-Conductive Coating Thickness	Can measure non-conductive coating thickness from 0 mm to 1.000 mm. Accuracy of 0.025 mm (±0.001 in.) over a 0 mm to 0.64 mm range
Rotating Scanner	MIZ-21C-SF: No, MIZ-21C: Yes, MIZ-21C-ARRAY: Yes Zetec Rotating Scanner, Others
Maximum Data File Size	60 MB
Languages	English, Spanish, French, German, Chinese
Storage	8 GB SSD Internal, Any size through USB expansion
Instrument Calibration	ISO/IEC 17025:2005, Meets or exceeds manufacturer's requirements

General Specifications

Voltage: 100 to 240 VAC, Auto-Switching

Frequency: 50 to 60 Hz

Output Voltage: 15 VDC

Maximum Power: 40 W

Operating Temperature Range: -10°C to 45°C (14°F to 113°F)

Storage Temperature Range: -20°C to 70°C (-4°F to 158°F)
(w/out batteries)

Relative Humidity: 95% non-condensing

CE mark is an attestation of the conformity with all applicable directives and standards of the European Community. WEEE, RoHS.

Accessories Ordering Information

111A801-00 - ZES-ADP-MIZ-21C_26-PIN_TO_26-PIN_SURF-X_ARRAY_PROBES_6FT

6 ft detachable cable from MIZ-21C 26-Pin Lemo to 26-Pin Lemo Surface Array Probe

111A802-00 - ZES-ADP-MIZ-21C_18-PIN_TO_12-PIN_GE_SCANNER_6FT

6 ft detachable cable from MIZ-21C 18-Pin Lemo to 12-Pin Lemo Rotating Scanners

111A803-00 - ZES-ADP-MIZ-21C_18-PIN_TO_16-PIN_OLYMPUS_SCANNER_6FT

6 ft detachable cable from MIZ-21C 18-Pin Lemo to 16-Pin Lemo Rotating Scanners

111A804-00 - ZES-ADP-MIZ-21C_18-PIN_TO_MICRODOT_PROBES_6FT

6ft detachable cable from MIZ-21C 18-Pin Lemo to Coaxial Microdot Probes

111A805-00 - ZES-ADP-MIZ-21C_18-PIN_TO_TRIAX_PROBES_6FT

6 ft detachable cable from MIZ-21C 18-Pin Lemo to Triaxial Fischer Probes

111A806-00 - ZES-ADP-MIZ-21C_18-PIN_TO_3-PIN_ZETEC_PROBES_6FT

6 ft detachable cable from MIZ-21C 18-Pin Lemo to 3-Pin Zetec Probes

111A807-00 - ZES-ADP-MIZ-21C_18-PIN_TO_4-PIN_FISCHER_PROBES_1FT

1 ft detachable cable from MIZ-21C 18-Pin Lemo to 4-Pin Fischer Probes

111A810-00 - ZES-ADP-MIZ-21C_18-PIN_TO_18-PIN_ZETEC_SCANNER_6FT

6 ft detachable cable from MIZ-21C 18-Pin Lemo to 18-Pin Lemo Zetec Rotating Scanners

Environmental Tests

As per MIL-STD-810G

Cold Storage - 502.5 procedure I

Cold Operation - 502.5 procedure II

Heat Storage - 501.4 procedure I

Heat Operation - 501.4 procedure II

Temperature Shock - 503.5 procedure II

Vibration - 514.6 procedure I

Transit Drop - ISTA 1G

Drop Test - 516.6 procedure IV, 1.2 m (4 ft) with cover

Specifications included in this document are subject to change.

Ordering Information

111A901-00 - ZES-HHT-MIZ-21C-SF

Fully integrated single frequency handheld Eddy Current system featuring 1 input and 32 active channels on up to 2 coil probes. Supports Conductivity. System purchase includes: MIZ-21C unit, 2 battery packs, AC adapter, cover, stand, USB flash drive with user manual, certification, and hard carrying case.

111A902-00 - ZES-HHT-MIZ-21C

Fully integrated dual frequency handheld Eddy Current system featuring 1 input and 64 active channels on up to 2 coil probes. Supports Conductivity and Rotating Scanner. System purchase includes: MIZ-21C unit, 2 battery packs, AC adapter, cover, stand, USB flash drive with user manual, certification, and hard carrying case.

111A903-00 - ZES-HHT-MIZ-21C-ARRAY

Fully integrated dual frequency handheld Eddy Current system featuring 3 inputs and 192 active channels on up to 32 coil probes. Supports Conductivity, Rotating Scanner, and Surface Array. System purchase includes: MIZ-21C unit, 2 battery packs, AC adapter, cover, stand, USB flash drive with user manual, certification, and hard carrying case.

111A904-00 - ZES-HHT-MIZ-21C-SF_WIRELESS-LOCKED

Wireless locked version of MIZ-21C-SF.

111A905-00 - ZES-HHT-MIZ-21C_WIRELESS-LOCKED

Wireless locked version of MIZ-21C.

111A906-00 - ZES-HHT-MIZ-21C-ARRAY_WIRELESS-LOCKED

Wireless locked version of MIZ-21C-ARRAY.

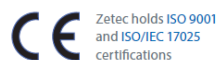

MIZ[®]-85iD



Characteristics

Flexible Performance

The MIZ-85iD family leverages the industry leading MIZ-80iD eddy current instrument technology into a modular “instrument only” alternative to the integrated all-in-one approach of MIZ-80iD System. The small rugged module is light weight and integrates easily in a multitude of inspection system scenarios. The completely sealed enclosure provides protection from environmental and radiological contamination to ensure integrity in electronic performance and allow serviceability throughout the life of the product.

Advanced features such as Auto Tube End Detection improve probe life while internal electronic differential reference signal and electronic connector pin multiplexer to eliminate the need for reference probes and common probe adapter cables. These features provide superior data quality and promote better analysis results.

Integration with probe delivery systems is provided through two independent Auxiliary I/O control lines to operate probe pushers such as the 10D probe pusher and provide direct integration with peripheral devices such as probe position encoders. On-board independent web servers allow for network configuration management and instrument calibration. Optional calibration module provides traceability in the calibration process to bureau of standards.

Features & Benefits

The MIZ-85iD is available in one or two probe standard model configurations. Each MIZ-85iD ships including a 1-year license of EddyNet/AQ acquisition software.

- Available in a dual or single probe configuration to best suit your application
- Supports all common steam generator inspection techniques
- Integral probe interface module (PIM) eliminates the need for probe adapters
- MIZ-iD Intelligent Device technology provides automatic probe configuration validation with MIZ-iD equipped probes

Specifications

FEATURE	GENERAL
Weight (without lid)	32.5 lbs. (14.75 kg)
Power	100-240 VAC, 50-60 Hz Auto Switching
Operational Temperature	32°F to 113°F (0°C to 45°C)
Storage Temperature	-4°F to 140°F (-20°C to 60°C)
Dimensions	11.5"H x 16.25"L x 14"W

FEATURE	EDDY CURRENT (ECT)
Frequency Range	20 Hz to 1.2 MHz
Gain	23-53 dB in 1 dB steps
Sample Rate	10Hz to 40 kHz
Drive Voltage	0-20 Vpp, 0-60 Vpp I-Probe mode
Coil Drive Amplifiers	Up to 2 per probe connector
Coil Input Amplifiers	Up to 8 per probe connector
Drive	0 – 20 Vpp
Supported Probe Technology	Array Probes, Bobbin Probes, and MRPC®
Channel Capability	40 Continuous Mode, 512 Multiplex, 640 Super-Multiplex
Maximum Sample Rates	Continuous Mode 40,000 Hz, Multiplex & Super-Multiplex 20,000 Hz

FEATURE	PROBING SYSTEM INTEGRATION
Analog servo control lines	±0-10 VDC
Solenoid function control lines	24 VDC
Auxiliary differential encoder inputs	Up to 2 / probe
Auxiliary limit switch input	1 / probe
External acquisition trigger	Option
CAN Bus device network integration	Option

Ordering Information

Part Number	Description	Details
10040998	ZEC-RDT-MIZ-85-1 SYSTEM +EDDYNET/AQ	MIZ-85iD-1 Remote Eddy Current Inspection Tester 1 Probe Model. Supports Bobbin, MRPC, X-Probe, I-Probe. Includes: -- Certification -- Filtered Power Cord -- Quick Start Guide -- Installation & Operating Manual -- Eddynet/AQ License Current Version + 1-Year SSP -- Shipping Case
10038840	ZEC-RDT-MIZ-85-1F_SYSTEM +EDDYNET/AQ	MIZ-85iD-1F Remote Eddy Current Inspection Tester 1 Probe Model for inspections with French Techniques. Supports Bobbin, MRPC, X-Probe, I-Probe and includes a French bobbin probe connector. -- Certification -- Filtered Power Cord -- Quick Start Guide -- English Language Installation & Operating Manual -- Eddynet/AQ License Current Version +1-Year SSP -- Shipping Case
10036516	ZEC-RDT-MIZ-85-2 SYSTEM +EDDYNET/AQ	MIZ-85iD-2 Remote Eddy Current Inspection Tester 2 Probe Model. Supports Bobbin, MRPC, X-Probe, I-Probe. Includes: -- Certification -- Filtered Power Cord -- Quick Start Guide -- Installation & Operating Manual -- Eddynet/AQ License Current Version + 1-Year SSP -- Shipping Case
10033416	ZEC-RDT-MIZ-85-2F_SYSTEM +EDDYNET/AQ	MIZ-85iD-2F Remote Eddy Current Inspection Tester 2 Probe Model for inspections with French Techniques. Supports Bobbin, MRPC, X-Probe, I-Probe and includes a French bobbin probe connector. Includes: -- Eddynet A/Q doesn't store the DATA to the EDF file format -- Eddynet A/Q doesn't drive the saturation current in the SAX probe -- Eddynet A/Q does drive the SAX mode but without the saturation coil -- Eddynet A/Q does not support the French MRPC Techniques -- Certification -- Filtered Power Cord -- Quick Start Guide -- English Language Installation & Operating Manual -- Eddynet/AQ License Current Version +1-Year SSP -- Shipping Case

10033415	ZEC-RDT-MIZ-85-4 SYSTEM +EDDYNET/AQ	MIZ-85iD-4 Remote Eddy Current Inspection Tester 4 Probe Model. Supports Bobbin, MRPC, X-Probe and I-Probe. Includes: -- Certification -- JEAG Calibration -- Filtered Power Cord -- Quick Start Guide -- English Language Installation & Operating Manual -- Eddynet/AQ License Current Version + 1-Year SSP -- Shipping Case

Software Options

Part Number	Description	Details
10042658	ZEC-SWS-PC-EDDYNET/ AN_V1.x_CO	Includes: <ul style="list-style-type: none"> Eddynet PC Manual Analysis (AN) 1year SSP
10042659	ZEC-SWS-PC-EDDYNET/ DM_V1.x_CO	Includes: <ul style="list-style-type: none"> Eddynet PC Data Management (DM) 1year SSP
10042657	ZEC-SWS-PC-EDDYNET/ AQ_V1.x_CO	Includes: <ul style="list-style-type: none"> Eddynet PC Acquisition (AQ) 1year SSP
10042660	ZEC-SWS-PC-EDDYNET/ AQ+DQV_V1.x_CO	Includes: <ul style="list-style-type: none"> Eddynet PC Acquisition (AQ) Data Quality Verification (DQV) 1year SSP
10032950	ZEC-SWS-PC-EDDYNET_ INSTALL_V1.x_SOFT_CD	Includes: <ul style="list-style-type: none"> Eddynet PC Acquisition (AQ) Software CD 1year SSP

Adapters – Tier 1

Part Number	Description	Details
10038239	ZEC-ADP-MIZ_36-PIN_TO_ 4-PIN_SOLID	Used for 4-Pin Bobbin probes. This is a short rigid adapter. Works on MIZ-80, MIZ-85, and MIZ-200.
10022045	ZEC-ADP-MIZ_36-PIN_TO_ 4-PIN_FLEX_6IN	This is the same adapter as 10038239 used for 4-Pin Bobbin probes, but it has a flexible 6" cable. Works on MIZ-80, MIZ-85, and MIZ-200.
009A802-00	ZEC-ADP-MIZ_36-PIN_TO_ DUAL_4-PIN_AC3	Used for dual 4-Pin AC3 probes. Works on MIZ-80, MIZ-85, and MIZ-200.
009A811-00	ZEC-ADP-MIZ_36-PIN_TO_ 41-PIN_BOBBIN	Used for MS5800 41-Pin Bobbin probes. Works on MIZ-80, MIZ-85, and MIZ-200.
10041339	ZEC-ADP-MIZ_36-PIN_TO_ 36-PIN_RG3-4	Used for RG3-4 probes. Works on MIZ-80, MIZ-85, and MIZ-200.
10022316	ZEC-ADP-MIZ_36-PIN_TO_ 10-PIN_MRPC_AND_5-PIN_MU_10IN	Used for 10-Pin/5-Pin MRPC probes (Supports 1 to 3 coils). Also used in China. Works on MIZ-80, MIZ-85, and MIZ-200.

Accessories and Spare Parts – Tier 2

Part Number	Description	Details
108745	RIBBON 6 INCH 10P DUAL ROW	Tier 2
10033741	PCBA, MIZ-85iD MRPC	Tier 2
10033821S	PCBA, MIZ-85iD PIM	Tier 2
10033884S	MIZ-85 PS BOARD ASSY	Tier 2
10033999	MIZ-85iD I/O board for I-Probes	Tier 2
10034022	Ethernet Switch, Industrial 5-Port	Tier 2
10034578	MOD PWR ENTRY 4A 2POLE IP65 REAR	Tier 2
10034581	Ethernet Connector	Tier 2
10035827	ETHERNET CABLE 1 FOOT SHIELDED	Tier 2
10036937	MIZ85-2 LOW VOLTAGE DIST. CABLING	Tier 2
10036938	MIZ85-2 +48V PS CONTROL CABLE	Tier 2
10037644	MIZ85 FAN ASSEMBLY	Tier 2
10037645	MIZ85 1-WIRE ASSEMBLY	Tier 2
EQEX015C	MUSKETEER ANALOG BOARD ASSY	Tier 2
EQEX018D	MUSKETEER DIGITAL BOARD ASSY	Tier 2

Eddy Current Probe Delivery

MIZ[®]-80iD

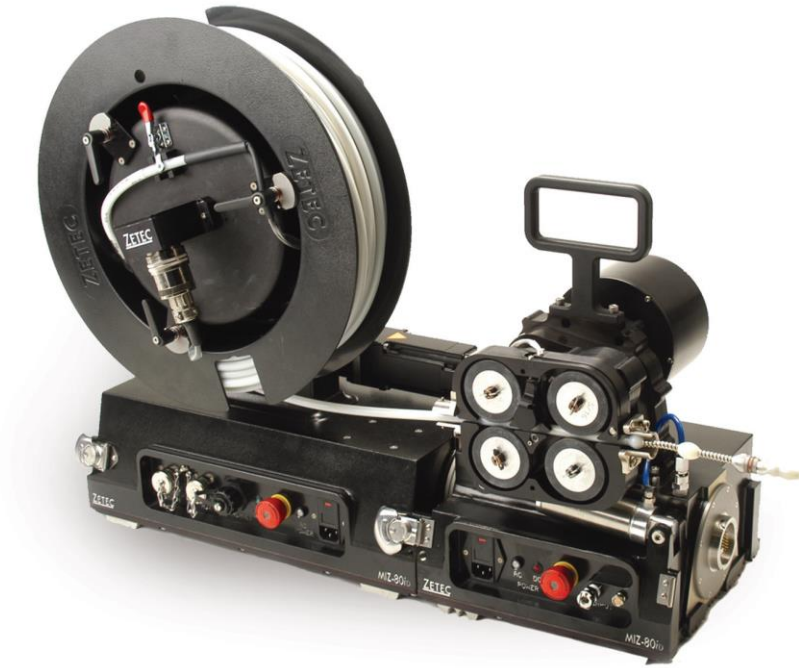

Characteristics

Integrated Perfection

The MIZ-80iD has revolutionized eddy current data acquisition for tubing inspections by providing an integrated eddy current instrument, probe pusher, and control system into one lightweight and efficient package. This innovative approach eliminates complexities associated with deployment, setup, and maintenance resulting in lower costs of operation and reduced human radiation exposure.

A modular design allows the MIZ-80iD to quickly be separated into three modules for ease of handling and transportation. Advanced locating features manage probe life by developing motion profiles to control speeds and positioning of the probes to reduce the risk of probe damage.

Features & Benefits

The MIZ-80iD is ready to revolutionize your inspection experience.

- All-in-one eddy current instrument, probe pusher, and controller reduces system setup from hours to minutes
- Supports all common steam generator inspection techniques
- Integral probe interface module (PIM) eliminates the need for probe adapters
- Integral eddy current instrument improves data quality by the elimination of probe extensions and slip-rings
- MIZ-iD Intelligent Device technology provides automatic probe configuration validation with MIZ-iD equipped probes

Specifications

FEATURE	GENERAL
Power	100-240 VAC 50-60 Hz
Operational Temperature	32°F to 113°F (0°C to 45°C)
Storage Temperature	-4°F to 140°F (-20°C to 60°C)

FEATURE	EDDY CURRENT INSTRUMENT
Weight	7.0lb (3.18kg)
Size	13.0" dia x 7.0"W (33.0 x 17.8 cm)
Frequency Range	20 Hz to 1 MHz
Drive	0 – 20 Vpp
Supported Probe Technology	Array Probes, Bobbin Probes, and MRPC®
Channel Capability	40 Continuous Mode, 512 Multiplex, 640 Super-Multiplex
Gain	23-53 dB in 1 dB steps, variable
Maximum Sample Rates	Continuous Mode 40,000 Hz, Multiplex & Super-Multiplex 20,000 Hz

FEATURE	TAKE-UP REEL
Weight	40.2 lb (18.2 kg)
Size	21"H x 18"L x 11"W (53.3 x 45.7 x 28.0 cm)
Inputs/Outputs	Ethernet 10/100Base T

FEATURE	PUSHER DRIVE
Weight	43.8 lb (19.9 kg)
Size	18"H x 11"L x 11"W (45 x 28 x 28 cm)
Probe Speeds	X-Probe 40 inches/second (101 cm/second) Bobbin 95 inches/second (241 cm/second) MRPC +Point 2 inches/second (5 cm/second)

Ordering Information

Part Number	Description	Details
10021170	ZEC-RDT-MIZ-80ID-SYSTEM	MIZ-80iD Integrated Eddy Current Inspection System Includes: -- Certification -- 2ea Filtered AC Power Cords -- Fenders (5/16), Black Wheels (5/16) -- Wheel Safety Cover -- Conduit Lock Kit, Air Adapter -- Quick Start Guide -- Installation & Operating Manual and Shipping Case -- MIZ-80iD hardware
10031064	ZEC-RDT-MIZ-80ID-SYSTEM_CE	MIZ-80iD Integrated Eddy Current Inspection System with CE MARK Includes: -- Certification -- 2ea Filtered AC Power Cords -- Fenders (5/16), Black Wheels (5/16) -- Wheel Safety Cover, Spool Safety Cover -- Conduit Lock Kit, Air Adapter -- Quick Start Guide -- Installation & Operating Manual and Shipping Case -- MIZ-80iD hardware with CE equipment
10030725	ZEC-RDT-MIZ-81ID-SYSTEM	MIZ-81iD Integrated Eddy Current Inspection System Includes: -- Certification -- 2ea Filtered AC Power Cords -- Fenders (5/16), Black Wheels (5/16) -- Wheel Safety Cover, Spool Safety Cover -- Conduit Lock Kit, Air Adapter -- Quick Start Guide -- Installation & Operating Manual and Shipping Case -- MIZ-81iD hardware -- 1ea Probe Adapter SAX/STL -- 1ea Probe Adapter MIZ-81iD 36 Pin

Software Options

Part Number	Description	Details
10042658	ZEC-SWS-PC-EDDYNET/ AN_V1.x_CO	Includes: <ul style="list-style-type: none"> Eddynet PC Manual Analysis (AN) 1year SSP
10042659	ZEC-SWS-PC-EDDYNET/ DM_V1.x_CO	Includes: <ul style="list-style-type: none"> Eddynet PC Data Management (DM) 1year SSP
10042657	ZEC-SWS-PC-EDDYNET/ AQ_V1.x_CO	Includes: <ul style="list-style-type: none"> Eddynet PC Acquisition (AQ) 1year SSP
10042660	ZEC-SWS-PC-EDDYNET/ AQ+DQV_V1.x_CO	Includes: <ul style="list-style-type: none"> Eddynet PC Acquisition (AQ) Data Quality Verification (DQV) 1year SSP
10032950	ZEC-SWS-PC-EDDYNET_ INSTALL_V1.x_SOFT_CD	Includes: <ul style="list-style-type: none"> Eddynet PC Acquisition (AQ) Software CD 1year SSP

Adapters – Tier 1

Part Number	Description	Details
10038239	ZEC-ADP-MIZ_36-PIN_TO_ 4-PIN_SOLID	Used for 4-Pin Bobbin probes. This is a short rigid adapter. Works on MIZ-80, MIZ-85, and MIZ-200.
10022045	ZEC-ADP-MIZ_36-PIN_TO_ 4-PIN_FLEX_6IN	This is the same adapter as 10038239 used for 4-Pin Bobbin probes, but it has a flexible 6" cable. Works on MIZ-80, MIZ-85, and MIZ-200.
009A802-00	ZEC-ADP-MIZ_36-PIN_TO_ DUAL_4-PIN_AC3	Used for dual 4-Pin AC3 probes. Works on MIZ-80, MIZ-85, and MIZ-200.
009A811-00	ZEC-ADP-MIZ_36-PIN_TO_ 41-PIN_BOBBIN	Used for MS5800 41-Pin Bobbin probes. Works on MIZ-80, MIZ-85, and MIZ-200.
10041339	ZEC-ADP-MIZ_36-PIN_TO_ 36-PIN_RG3-4	Used for RG3-4 probes. Works on MIZ-80, MIZ-85, and MIZ-200.
10022316	ZEC-ADP-MIZ_36-PIN_TO_ 10-PIN_MRPC_AND_5-PIN_MU_10IN	Used for 10-Pin/5-Pin MRPC probes (Supports 1 to 3 coils). Also used in China. Works on MIZ-80, MIZ-85, and MIZ-200.

Accessories – Tier 1

Part Number	Description	Details
10021181	ZEC-ADP-MIZ-80ID-SENSE_COIL	MIZ-80iD Sensing Coil Adapter
10021293	ZEC-ACC-MIZ-80ID-ANNUAL_CAL_MOD	MIZ-80iD Annual Calibration Module
10021387	ZEC-ACC-MIZ-80ID-PRE/POST_CAL_PLUG	MIZ-80iD Pre/Post Calibration Check Plug
10021746	ZEC-ACC-MIZ-80ID-TENSIONER	Manual Tensioner for Pusher Wheels
10022488	ZEC-SP-MIZ-80-TU_SPOOL_COVER	MIZ-80iD TURC Spool Replacement Safety Cover
10023270	ZEC-ACC-MIZ-80ID-J-ADAPTER_KIT	MIZ-80iD Intelligent Probe interface kit
10024280	ZEC-SP-MP-LG_DRV_WHEEL_5/16_BLK_1	MIZ-80iD & 10D Pusher Drive Wheel, 5/16 Black Buna 70/80 Type 1
10024789	ZEC-ADP-SIO-CONTROL_CABLE	Sensor I/O Control Cable, 20FT
10024797	ZEC-SP-PUSHER-SPOOL_18IN	18" diameter probe spool. Compatible with current Zetec probe pushers
10031599	ZEC-ACC-MIZ-80ID-REM_OP_CABLE_6FT	ZEC-ACC-MIZ-80ID-REM_OP_CABLE_6FT
10035272	ZEC-ACC-MIZ-80ID-JEAG_ANNUAL_CAL_MOD_KIT	MIZ-80iD JEAG Calibration module kit. Includes calibration module, injector cable, procedure and fitted case
10004968-10	ZEC-ACC-SIO-W/.750_J-LOC	Zetec Inline Coil Sensor with 4-pin Lemo connector, .750ID with J-Loc connectors
10021230-1	ZEC-ACC-MIZ-80ID-VAC_COVER_PW	Vacuum Cover Attachment for Pusher Wheels
10022288-1	ZEC-ACC-MIZ-80ID-SPOOL_SAFE_COVER	MIZ-80iD TURC Spool Safety Cover Kit, Includes mounting hardware

Non-Teflon Conduit

Sales Part No	Sales Part Description
10035763	ZEC-ACC-JLOC_THD_COND_3/4X9FT
10035773	ZEC-ACC-JLOC_THD_COND-3/4X.5FT
10035767	ZEC-ACC-JLOC_THD_COND-3/4X1.5FT
10035765	ZEC-ACC-JLOC_THD_COND-3/4X10FT
10035766	ZEC-ACC-JLOC_THD_COND-3/4X12FT
10035768	ZEC-ACC-JLOC_THD_COND-3/4X18FT
10035764	ZEC-ACC-JLOC_THD_COND-3/4X1FT
10035770	ZEC-ACC-JLOC_THD_COND-3/4X20FT
10035769	ZEC-ACC-JLOC_THD_COND-3/4X2FT
10035771	ZEC-ACC-JLOC_THD_COND-3/4X3FT
10035772	ZEC-ACC-JLOC_THD_COND-3/4X4FT
10035774	ZEC-ACC-JLOC_THD_COND-3/4X5FT
10035775	ZEC-ACC-JLOC_THD_COND-3/4X6FT
10035776	ZEC-ACC-JLOC_THD_COND-3/4X8FT
10040736	ZEC-ACC-JLOC_THD_COND-SET_B_3/4

System - Tier 1

Part Number	Description	Details
108398	SEC-SP-MIZ-80ID-BALL_LOCK_PIN	MIZ-80iD Ball-Lock Pin
111125	ZEC-SP-MP-10_AMP_FUSE	Fuse, SLO-BLO ~ MDA 10 AMP 250V
116193	ZEC-SP-MP-FILTERED_POWER_CORD	Filtered Power Cord
10021878	ZEC-CAL-MIZ-80ID-ASFAL_CERT+RFU	MIZ-80iD annual calibration certification including system ready for use checkout and maintenance
10035906	ZEC-CAL-MIZ-80ID-ASFAL_CERT_ONLY	MIZ-80iD annual calibration certification

Instrument - Tier 1

Part Number	Description	Details
10021168	ZEC-SP-MIZ-80ID-INST_CONN_ASSY	MIZ-80iD Instrument Probe Connector Assy
10021234	ZEC-RDT-MIZ-80ID-INSTRUMENT	MIZ-80iD Instrument Module
10021300	MIZ-80ID INSTRUMENT SPOOL CLAMP ASS	
10021776	PROBE POLY CLAMP KIT	
10026010	ZEC-RDT-MIZ-81ID-SAX/STL_PRB_MOD	MIZ-81iD SAX/STL Probe Connector Module

TURC - Tier 1

Part Number	Description	Details
10036214	CLOSURE CAP W/ LAYNARD, IP67 RATED	Ethernet Weather Cap
109076	ZEC-SP-MIZ-80ID-CASE_TURC	MIZ-80iD Take-up Reel Storage Case
110796	SEC-SP-MIZ-80ID-TURC_I/O_CAP	TURC Aux I/O & Sync Weather Cap
10020990	ZEC-SP-MIZ-80-TU_MTR/ENC_WIRG	MIZ-80iD TURC MOTOR AND ENCODER WIRING. B.
10032412	ZEC-SP-MIZ-80ID-TURC_HS_COVER	ZEC-SP-MIZ-80/81ID-TURC_WR_HS_COVER
10021233	ZEC-RDT-MIZ-80ID-TURC	MIZ-80iD Take Up Module (Turc)
10024797	ZEC-SP-PUSHER-SPOOL_18IN	ZEC-SP-10D-SPOOL_18IN
10024806	ZEC-SP-10D-SPOOL_16IN	ZEC-SP-10D-SPOOL_16IN
25EEE0004	TIMING BELT, 5MM PITCH, 15MM WIDE	

Pusher - Tier 1

Part Number	Description	Details
103731	1 QUART BOTTLE 80W90 WEIGHT OIL W/	
104514	1/8ID PIPE THREAD SHUTOFF 1/8NPT CB	
104928	BREATHER FILTER	
109075	ZEC-SP-MIZ-80ID-CASE_PUSHER	MIZ-80iD Pusher Head and Instrument Storage Case
10004951	BUTTERFLY LOCK (KIT)	
10019932	HANDLE ARM	
10032408	SEC-SP-MIZ-80/81ID-PH_WR_HOTSHOE_COVER	MIZ-80iD Pusher Head Hot Shoe Cover Sub-Assembly
10021232	ZEC-RDT-MIZ-80ID-PUSHER	MIZ-80ID Pusher Module For 5/16-3/8 Poly
10021780	REPLACEMENT FENDER BRUSH ASSY	
10024280	ZEC-SP-MP-LG_DRV_WHEEL_5/16_BLK_1	MIZ-80iD Drive Wheel, Black material grooved for 3/8" shaft
10024281	ZEC-SP-MP-LG_DRV_WHEEL_3/8_BLK_1	MIZ-80iD Drive Wheel, Black material grooved for 7/16" shaft
10024282	ZEC-SP-MP-LG_DRV_WHEEL_1/2_BLK_1	MIZ-80iD Drive Wheel, Black material with no groove
10024281	ZEC-SP-MP-LG_DRV_WHEEL_3/8_BLK_1	MIZ-80iD Drive Wheel, Black material grooved for 7/16" shaft
10024282	ZEC-SP-MP-LG_DRV_WHEEL_1/2_BLK_1	MIZ-80iD Drive Wheel, Black material with no groove
10024283	ZEC-SP-MP-LG_DRV_WHEEL_1/4_BLK_1	MIZ-80iD Drive Wheel, Black material grooved for 5/16" shaft
10024284	ZEC-SP-MP-LG_DRV_WHEEL_7/16_BLK_1	MIZ-80iD Drive Wheel, Black material grooved for 1/2" shaft
10024285	ZEC-SP-MP-LG_DRV_WHEEL_1/8_BLK_1	MIZ-80iD Drive Wheel, Black material grooved for 1/8" shaft
10024286	ZEC-SP-MP-LG_DRV_WHEEL_BLK_BLANK	MIZ-80iD Drive Wheel, Black material with no groove
10024287	ZEC-SP-MP-LG_DRV_WHEEL_TAN_1/4_1	MIZ-80iD Drive Wheel, Tan material grooved for 5/16" shaft
10024288	ZEC-SP-MP-LG_DRV_WHEEL_TAN_5/16_1	MIZ-80iD Drive Wheel, Tan material grooved for 7/16" shaft
10024289	ZEC-SP-MP-LG_DRV_WHEEL_TAN_7/16_1	MIZ-80iD Drive Wheel, Blue material grooved for 5/16" shaft
10024291	ZEC-SP-MP-LG_DRV_WHEEL_BLU_5/16_2	MIZ-80iD Drive Wheel, White material grooved for 1/4" shaft
10024292	ZEC-SP-MP-LG_DRV_WHEEL_WHT_1/4_2	MIZ-80iD Drive Wheel, White material grooved for 5/16" shaft
10024293	ZEC-SP-MP-LG_DRV_WHEEL_WHT_5/16_2	MIZ-80iD Drive Wheel, White material grooved for 3/8" shaft
10024294	ZEC-SP-MP-LG_DRV_WHEEL_WHT_3/8_2	MIZ-80iD Drive Wheel, White material grooved for 3/8" shaft
10026346	ZEC-SP-MP-LG_DRV_WHEEL_TAN_BLANK	MIZ-80iD Drive Wheel, Tan material grooved for 1/4" shaft
10031234	MIZ-80 ENCODER ASSY, SPARE	
10020650-6	ZEC-SP-MIZ-80ID-AIR_ADP_6FT	MIZ-80ID Shop Air Adapter, 6FT
10021177-1	ZEC-ACC-MIZ-80ID-LR_FEND_ASSY_1/4	MIZ-80 Fender Sub-Assembly, 1/4 Poly

10021177-2	ZEC-ACC-MIZ-80ID-LR_FEND_ASSY_3/8	MIZ-80 Fender Sub-Assembly, 5/16-3/8 Poly
10021177-3	ZEC-ACC-MIZ-80ID-LR_FEND_ASSY_1/2	MIZ-80 Fender Sub-Assembly, 11MM-1/2 Poly
10021226-1	ZEC-SP-MIZ-80ID-WHEEL_SAFE_COVER	MIZ-80iD Universal Wheel Safety Cover With Ball Locks
10021640-2	ZEC-SP-MIZ-80ID-UP_FEND_ASSY_5/16	MIZ-80 Top Fender Sub-Assembly With Encoder Cable, 5/16-3/8

Instrument - Tier 2

Part Number	Description	Details
10021057	ZEC-SP-MIZ-80-INST_MIZ-iD_ASSY	MIZ-80iD Instrument MIZ-iD assy for the housing
10021265	ZEC-SP-MIZ-80-INST_FAN	COOLING FAN, MIZ-80ID INSTRUMENT, 3 INCHES
10021775	INSTRUMENT LOCK RING KIT	
10021777	INSTRUMENT LID REPLACEMENT	
10021781	ZEC-SP-MIZ-80-INST_CABLE_KIT	CABLE KIT, MIZ-80ID INSTRUMENT
10021926	ZEC-SP-MIZ-80-INST_FAST_KIT	MIZ-80iD Instrument Fastener Kit
10022384	MIZ-80ID INSTRUMENT DIGITAL BOARD	
10022385	MIZ-80ID INSTRUMENT ANALOG BD	
10022386	MIZ-80ID INSTRUMENT PIM BOARD	
10022387	MIZ-80ID INSTRUMENT DC BOARD	

TURC - Tier 2

Part Number	Description	Details
107845	SERVO AMPLIFIER, 5A, 230VAC, BASOON	
107847	GEARHEAD, NEMA 23, 7:1, RIGHT ANGLE	
108316	DRAW LATCH	
108730	FAN W/HSINK, 5V, 23MM FPGA CLIP	
109127	PERFORMANCE FILTER, 10A W/ FAST	
10020998	ZEC-SP-MIZ-80-Z1-872_LED_WIRG	MIZ-80ID J5 Z1-872 LINK LED WIRING. B.
10021069	POWER SUPPLY ASSEMBLY	
10021151	SLIP RING SUB-ASSEMBLY, MIZ-80ID	
10021152	ZEC-SP-MIZ-80-TU_HS_SUBASSY	TURC HOT SHOE SUB-ASSEMBLY, MIZ-80ID
10021302	ZEC-SP-MIZ-80-TU_FAN	24V COOLING FAN, MIZ-80ID TUR, 3 INCHES
10035397	ETHERNET MOD	
10021782	ZEC-SP-MIZ-80-TU_CABLE_KIT	CABLE KIT, MIZ-80ID TAKE-UP REEL CONTROLLER
10021927	ZEC-SP-MIZ-80-TU_FAST_KIT	MIZ-80iD Take-Up Reel Controller Fastener Kit
25BBE0006	BEARING, SINGLE ROW, DEEP GROOVE, S	
MKTXE013A	MKTR LOWER PULLEY 17T	
MKTXE014A	MKTR TOP PULLEY 40T	
MQTXE163A	MKTR TOP PULLEY KEY	
MSTXE006A	MKTR TAKE UP HANDLE	
10022388	MIZ-80ID TURC DIGITAL BOARD	

10022389	MIZ-80ID TURC ANALOG BOARD	
Z1-872-1	PCB, MUSKETEER TAKEUP PANEL AUX I/O	

Pusher - Tier 2

Part Number	Description	Details
103981	10D AC FILTER RH1	
107408	POWER ENTRY MODULE, P SERIES, NO SW	
108315	DRAW-LATCH KEEPER	
108461	SERVO AMPLIFIER, DIGITAL, 100- 240V	
114499	AIR HOSE, CLEAR 1/4 OD X 1/8 ID	
10020985	ZEC-SP-MIZ-80-MAC_VALVE_ASSY	MIZ-80 MAC VALVE WIRING ASSY. B.
10020999	ZEC-SP-MIZ-80-PH_MTR_WIRG	MIZ-80ID PUSHERHEAD MOTOR WIRING ASSEMBLY. B.
10021059	MIZ-80ID PANEL DC LED WIRING	
10021155	PUSHER HEAD HOT SHOE SUB- ASSEMBLY,	
10021778	BIMBA AIR CYLINDER REPLACEMENT	
10021779	ZEC-SP-MIZ-80ID- PH_MTR_ENC_RPL_KIT	MIZ-80iD Pusher Motor Velocity Encoder Replacement Kit
10021783	ZEC-SP-MIZ-80-PH_CABLE_KIT	CABLE KIT, MIZ-80ID PUSHER HEAD
10021928	ZEC-SP-MIZ-80-PU_FAST_KIT	MIZ-80iD Pusher Head Controller Fastener Kit
10019800-1	PUSHER HEAD ASSEMBLY	PUSHER HEAD ASSEMBLY

ZR-100



Characteristics

Inspection and Repair Robot

Field proven to be faster and easier to use than any other inspection or repair robot. You can install and calibrate two ZR-100 robots in less than 20 minutes. Run up to two robots and four Zetec probes in each channel head. Operate each robot and dual probes with the MIZ- 80iD integrated acquisition system simultaneously using EddyNet/AQ software. Efficiently inspect every tube and analyze data quickly with EddyNet®/AN or RevospECT™. Change tools remotely without removing the robot for complete and efficient inspection to repair operations. Reconfigure the robot in less than an hour for a different steam generator inspection.

Features & Benefits

- Quick, accurate and reliable
- Smallest footprint and most agile robot available
- Multiple robots conveniently controlled from EddyNet/AQ software
- A completely non-entry installation that is both fast and easy
- Supports Eddy Current and Repair Tools
- Easily configured for various steam generator models

Quick, Accurate and Reliable

- Can quickly inspect every tube in the steam generator faster than any other robot
- All eddy current and repair tools can reach every steam generator tube
- Field proven in horizontal and vertical OTSG in-service inspections and vertical pre-service inspections

Intelligent Motion

- Allows for multiple robots within same vessel for high productivity
- Multi-robot awareness system intelligently coordinates multiple robots within same vessel to avoid collisions
- Multi-robot awareness system coordinates probing to avoid pushing a probe into an adjacent plenum robot

Easy and Fast Installation

- ZR-100 installation system and the EddyNet™/AQ install wizard allow for an easier and faster installation than any other robot
- The installation process is based on controlled science and process to be less demanding of the operator
- The zero entry installation positions the operators for the lowest dose achievable during installation
- Allows you to be collecting data from up to four MIZ-80s in less than 20 minutes from platform arrival

Supports Eddy Current and Repair Tools

- Zetec's dual guide tube tool allows for testing of 2 tubes simultaneously per ZR-100
- Quickly change to roll plugging, TIG shrinker insert, plug puller insert, stake installation and plug inspection tools
- Up to 30 lb tool payload

Specifications

FEATURE	ENVIRONMENTAL
Operating Temperature	4°C - 49°C / 40°F - 120°F
Storage Temperature	-40°C - 60°C / -40°F - 140°F
Operating Humidity	10 - 95% RH
Storage Humidity	10 - 95% RH
Sound	69 dB max
Vibration	4 Sine Sweeps from 5Hz-500Hz Op/Non-Op, Each axis 10 minutes random vibrate Op/Non-Op. PSD=0.7G RMS
Shock: Robot/Controller/Cable	3+/- pulses each, 30G at 5ms and 3+/- pulses each, 28G at 11ms X, Y, Z axis Op
Shock: Install Carriage	3+/- pulses each, 30G at 5/11ms X, Y, Z axis Op

FEATURE	OPERATIONAL
Power	90 - 265 VAC, 47 - 63Hz, auto switching, 8A maximum amps
Plant Air Pressure	80 - 100 PSI (5.5 - 6.9 bar) recommended, 110 PSI (7.6 bar) maximum
Plant Air Connector	1/4" male thread connection

FEATURE	FUNCTIONAL
ZR-100 Base Robot System	32"W x 27"W x 17"H (.81mW x .69mW x .53mH), includes: Robot (unloaded ZR-100 robot weight 37lbs (16.78kg))
Install Hardware	24"L x 15"W x 23"H (.61mL x .38mW x .58mH), includes: Install Carriage (15lbs (6.80kg))
Radiation Immunity	Zero adverse effect when operating in 20 REM/hr field
Water Ingress	Meets spec IP-X5 (3.25 gal/min low pressure spray for 3 minutes)
Speed	Up to 4" per second (.10m/sec), guide tubes can locate a new tube in less than one second
Payload	30lbs (13.6kg) in a horizontal tubesheet (including weights of cables and conduit), 15lbs (6.8kg) in a vertical tubesheet.

Ordering Information

Part Number	Description	Details
10048624-X	ZEC-ROB-ZR-100-SD_SYS_X	ZR-100 Robot System includes: Robot, Staggered DGT, Control Box, Operation Guide, Filtered Power Cord, 60ft Robot Main Cable and Hard Shipping Case, Eddyner AQ Install Disk, 1-year Factory Warranty. (X = Tube OD and Pitch)
10049925-X	ZEC-ROB-ZR-100-SYS_NO_DGT_X	ZR-100 Robot System includes: Robot, Control Box, Operation Guide, Filtered Power Cord, 60ft Robot Main Cable and Hard Shipping Case, Eddyner AQ Install Disk, 1-year Factory Warranty. Does not include Staggered DGT. (X = Tube OD and Pitch)
10033332-X	ZR-100 Configured Robot	Robot only, does not include DGT, Controller, Cal Plate, Shipping Case, or related cables. (X = Tube OD and Pitch)

Software Options

Part Number	Description	Details
10042658	ZEC-SWS-PC-EDDYNET/ AN_V1.x_CO	Includes: <ul style="list-style-type: none"> Eddyner PC Manual Analysis (AN) 1year SSP
10042659	ZEC-SWS-PC-EDDYNET/ DM_V1.x_CO	Includes: <ul style="list-style-type: none"> Eddyner PC Data Management (DM) 1year SSP
10042657	ZEC-SWS-PC-EDDYNET/ AQ_V1.x_CO	Includes: <ul style="list-style-type: none"> Eddyner PC Acquisition (AQ) 1year SSP
10042660	ZEC-SWS-PC-EDDYNET/ AQ+DQV_V1.x_CO	Includes: <ul style="list-style-type: none"> Eddyner PC Acquisition (AQ) Data Quality Verification (DQV) 1year SSP
10032950	ZEC-SWS-PC-EDDYNET_ INSTALL_V1.x_SOFT_CD	Includes: <ul style="list-style-type: none"> Eddyner PC Acquisition (AQ) Software CD 1year SSP

Configuration Parts – Tier 1

Part Number	Description	Details
10048627-X	ZEC-ROB-ZR-100-SD_CONV_X	DGT Robot Conversion Kits (X = Tube OD and Pitch) Includes: Staggered Dual Guide Tube (DGT), 7 Gripper Heads, Configuration Plates; Does not include Calibration Plate, only one required per SG. Does not include conduit connectors, 2 required per DGT.
10030659-X	ZEC-ROB-ZR-100-PCONFIG_KIT_X	Config Plates and Hardware (X = Pitch) Includes: 1 Pod Config Plate, 2 Leg Config Plates
10048628-1	ZEC-ROB-ZR-100-GRIPPER_HEAD_V3_549	Gripper for 5/8 x .038 Tube (7 required per Robot, 2 per Install Anchor Kit) Nom Operating ID .554
10048628-2	ZEC-ROB-ZR-100-GRIPPER_HEAD_V3_608	Gripper for 11/16 x .040 Tube (7 required per Robot, 2 per Install Anchor Kit) Nom Operating ID .611
10048628-3	ZEC-ROB-ZR-100-GRIPPER_HEAD_V3_664	Gripper for 3/4 x .043 Tube (7 required per Robot, 2 per Install Anchor Kit) Nom Operating ID .669
10048628-4	ZEC-ROB-ZR-100-GRIPPER_HEAD_V3_775	Gripper (7 required per Robot, 2 per Install Anchor Kit) Nom Operating ID .780
10048628-5	ZEC-ROB-ZR-100-GRIPPER_HEAD_V3_630	Gripper for 7/8 x .039 Tube (7 required per Robot, 2 per Install Anchor Kit) Nom Operating ID .636
10048628-6	ZEC-ROB-ZR-100-GRIPPER_HEAD_V3_530	Gripper for 5/8 x .044 and 5/8 x .0445 Tube (7 required per Robot, 2 per Install Anchor Kit) Nom Operating ID .540
10048628-7	ZEC-ROB-ZR-100-GRIPPER_HEAD_V3_620	Gripper for 19.05mm x 1.65mm Tube (7 required per Robot, 2 per Install Anchor Kit) Nom Operating ID .621
10048628-9	ZEC-ROB-ZR-100-GRIPPER_HEAD_V3_792	Gripper for 7/8 x .049 and 7/8 x .050 Tube (7 required per Robot, 2 per Install Anchor Kit) Nom Operating ID .792
10048732-X	ZEC-ROB-ZR-100-CAL_PLT_X	Calibration Plate (X = Tube OD and Pitch), 1 is required per generator.
10048524-X	ZEC-ROB-ZR-100-STG_DGT_X	ZR-100 Staggered Dual Guide Tube (X = Tube OD and Pitch)
10046626-X	ZEC-ROB-ZR-100-DGT_KIT_TO_STG_X	DGT Upgrade Kit Popper to Staggered (X = Tube OD and Pitch)
10046625-X	ZEC-ROB-ZR-100-COM-SGT_X	ZR-100 Common Single Guide Tube (X = Tube OD)

Accessories – Tier 1

Part Number	Description	Details
10034169-X	ZEC-ROB-ZR-100-IN_HW_X	ZR-100 Robot Installation Hardware Kit includes: Install Carriage, 60ft Install Cable, Installation Stick, Anchor Kit (X = Tube OD and Pitch)
10033831	ZEC-ROB-ZR-100-INSTALL_CARRIAGE	Installation Carriage
10033943	ZEC-ROB-ZR-100-INSTALL_BRKT ASSY	Installation Pole & T-Bar, Gripper Heads not included
10034168-X	ZEC-ROB-ZR-100-ANCHOR_KIT_X	Includes: Anchors, 2 Gripper Heads, Poly and T-Bar Alignment Pins
001A000-04-XX-X	ZEC-ROB-ZR-100-CUSTOMER_TS MOCKUP_X	Customer Tube Sheet Mockups (dimensions W=32" L=25" H= 1.35") (3 Zones SG Exp Tube ID: Min, Nom, Max) Requires Stand 10035310
10035310	ZEC-ROB_ZR-100-TUBESHEET_STAND	Stand for hold traveling tube sheets - tubesheet not included, weight 41 lb.
10040101-X	ZR-100 SOLID GT PASS/FAIL ALIGNMENT TOOL_X	Measuring sticks for DGT accuracy in the tubesheet. (X = Expanded Tube ID)
10046035	ZR-100 POD EXT AIR/CABLE FIXTURE	
10043564	20-200 in-lb adj torque wrench, ¼" dr	Torque wrench to tighten gripper heads to 80 in-lb
10043565	6mm socket, ¼" drive	Socket to tighten gripper heads for torque wrench
10046385	ZR-100 Comprehensive Tool Kit	For customers that purchase PMLSP
10041748	ZR-100 Specialty Tool Kit	Contains the below 8 items (4 of 10036632, 1 each rest)
10041747	ZR-100 Leg Timing Jig	Used along with 2 1/8 x 1/2 dowel pins to time the 2 legs
10041746	Stride Drive Pulley Socket	Used to hold item 19 on 10030591 assembly while tightening item 35
10041745	Stride Drive Shim Tool	Used to correctly space item 19 on 10030591 assembly
10036632	Stride Assembly Shim	Used for correctly spacing the 2 rear stride pulleys when locking/timing the legs
10031530	Stride Pulley Spanner	Used for installing and tightening the 4 stride pulley bearing housing assemblies. Item 36 on 10031383 assy
10041825	ZR-100 Slip Ring Connector Align Tool	
10041803	Sonic Tension Meter	
10041802	Wrench, S-Shape Box, 5/16"-3/8", 12-Point	
001A112-05-X	Toe clips	Dash numbers match Gripper Head dash numbers.
10038638	ZEC-ROB-ZR-100-CONFIG_SCREW_KIT_HW	Replacement screw kit whenever config plates are changed for robots with rubber bumpers. 40 screws (3 sizes), 35 o-rings (4 sizes) and 1 tube of o-lube
10043078	ZEC-ROB-ZR-100-CONFIG_SCREW_KIT_HW_TOP_MOUNT	Replacement screw kit whenever config plates are changed for robots without rubber bumpers. 40 screws (3 sizes), 35 o-rings (4 sizes) and 1 tube of o-lube
10041699	Kit of 7 Silicone Plugs, 3/4-1.0	Plugs for gripper modules when gripper heads removed for decontamination
101305	O-RING, .176 ID X .070 W	O-ring on front of tool head interface

Controller – Tier 1

Part Number	Description	Details
10029784	ZEC-ROB-ZR-100-CONTROLLER	ZR-100 Controller
116193	Power Cord	110V to controller AC adapter. Other voltages must be bought locally.
10037120	ZEC-ROB-ZR-100-CBL_MAIN_60FT	One 60ft and 1 30ft extension cable can be used. Same cable that ships with robot system
10037360	ZEC-ROB-ZR-100-CBL_INSTL_HW_60FT	One 60ft and 1 30ft extension cable can be used. Same Cable that ships with install HW
10031680	ZEC-ROB-ZR-100-CBL_EXT_MAIN_30FT	Up to one regular and 2 extension cables (90 ft) can be used
10033914	ZEC-ROB-ZR-100-CBL_EXT_INSTL_HW30FT	Up to one regular and 2 extension cables (90 ft) can be used
10030730	ZEC-ROB-ZR-100-CBL_MAIN_30FT	30ft main cable. Default cable changed from 30 to 60ft June 30, 2010
10033640	ZEC-ROB-ZR-100-CBL_INSTL_HW_30FT	30ft install cable. Default cable changed from 30 to 60ft June 30, 2010
114163	1/8 IDX1/8 ID MALE CONN AIR FITTING	Air connector for anchor, main cable and install cable blue poly airlines. Mates to controller, robot or carriage.
10037925	Dust Cap with Lanyard	Plant air cap
10036214	CLOSURE CAP W/ LAYNARD, IP67 RATED	Ethernet cap
107461	ECONOMY AIR FILTER	Filter for controller if separate
107797	REGULATOR	Filter / Regulator
10035236	PIPE SEALANT	DO NOT USE TEFLON TAPE. Use pipe sealant for entire air path on the controller.
10035024	Air Adapter, 1/4 NPT M to 1/8 NPT F	Air fittings plant in
104514	1/8 ID PIPE THREAD SHUTOFF 1/8 NPT	Air fittings outputs. 4 per controller
10037724	Caution Label, 80-110 Pressure Range	For controller
10038448	CE LABEL, ZR-100 CONTROLLER	For Controller - how different than serial number label
109030	LABEL, AC INFORMATION	For Controller
10021167	LABEL, ZETEC ~ MIZ-80ID	
10037722	Warning Label, 110 Max Air Pressure	For Controller
108435	WEEE PRODUCT COMPLIANCE LABEL	For Controller
10029809	ZR-100 CONTROLLER LABEL	For Controller - Has serial number
10035213	ZR CONTROLLER FRONT LABEL	For Controller
10037891	Danger Label, Start and Stop Movement	For Cal Plate - Need 2, one for each side of cal plate.
10037955	Danger Label, Pinch Points	For Cal Plate - Need 2, one for each side of cal plate.

Install Hardware – Tier 1

Part Number	Description	Details
001A415-00	3/8P-1/4 BAH AIR LINE KIT	SS pins connector barb(block), Airline, poly and toggle switch for anchors
10037360	ZEC-ROB-ZR-100-CBL_INSTL_HW_60FT	Install Cable
10039244	ZEC-ROB-ZR-100-IN_HW_INSTALL POLE	Pole only - has heat shrink to capture hardware
10035119-X	INSTALL BRKT ASSY-%875P	Alignment pins for install spreader bracket
1-036-1	ZEC-SP-3D-DRV_WHL_5/16_BLACK_A	Black wheels used on the install HW. 4 per carriage
10049579	ZEC-SP-ZR-100-INSTALL_POLY_REPL_KIT	Upgrade to Poly and Barb retention for original users.

Toolhead – Tier 1

Part Number	Description	Details
10034819-X	Guidetube Assy_X	X = Tube OD
10032199-1	DGT Tube Spacer, 5/8 x .070	Short spacer for secondary
10032199-2	DGT Tube Spacer, 5/8 x .770	Long spacer for primary
10033304-1	DGTTUBESPACER,11/16SHORT	Short spacer for secondary
10033304-2	DGTTUBESPACER,11/16LONG	Long spacer for primary
10033404-1	DGT TUBE SPACER, .750 SHORT	Short spacer for secondary
10033404-2	DGT TUBE SPACER, .750 LONG	Long spacer for primary also for Staggered DGT secondary
10049137	DGT TUBE SPACER, 3/4 PRIMARY	Short spacer for Staggered DGT Primary
10036398-1	DGT Tube Spacer 1, 18mm X .070 LG	Short spacer for secondary
10036398-2	DGT Tube Spacer 2, 18mm X .770 LG	Long spacer for primary
10039000-X	Bottom Bushing	Between DGT plastic and primary guide tubes.
10036400-1	FEMALE J-LOCK, 3/4 SHAFT, 5/8 THREADED	
10036400-2	FEMALE J-LOCK, 3/4 SHAFT, 11/16 THREADED	
10036400-3	FEMALE J-LOCK, 3/4 SHAFT, 3/4 THREADED	
10036400-4	FEMALE J-LOCK, 3/4 SHAFT, 7/8 THREADED	
10036400-5	FEMALE J-LOCK, 3/4 SHAFT, 18MM THREADED	
10039421-36	ZEC-ACC-JLOC_COND_STIFF-3/4X3FT	

Robot – Tier 2

Part Number	Description	Details
10049232	ZEC-ROB-ZR-100-GH_V3_REFRESH_KIT	For GH PNs 10048628-X Must be done by certified service representative. Robot owner is responsible for ensuring dose rate is at a suitable level to work on the gripper heads. Kit contains materials for refreshing 7 GHs.
10039889	GRIPPER CAPTURE HOUSING	Black Delrin Piece that may get damaged when friction patch is changed in GH
10028163	GRIPPER FRICTION PATCH	Pucks for gripper head. 6 per GH
10048761-X	ZEC-SP-ZR-100-GRIPPER_SHOE_V3_X	Matches Gripper Head configuration number.
10035410	ZR100, PRESSURE SENSOR WIRING	Robot Pressure sensor
10028166S	GRIPPER MODULE TESTED	Tested Gripper Modules for all units. Dip switches must be set for correct location.
103342	AIR HOSE, BLUE 1/4 OD X 1/8 ID	Air hose that attaches to the anchors. 44 ft is amount on the anchor BOM
10014258-1	HOSE RETAINER	
102441	1/8 OD MINIATURE AIR TUBING - BLUE	
10007260	MINIATURE HOSE RETAINER	
10035022	Air Barb Elbow, 1/16 NPT M to 1/4 ID Tube	
10035019	Air Barb Fitting, 1/4-28 M to 1/4 ID Tube	
10030943	AIR FITTING BARB 10-32 TUBE ID-1/8	Used in TI section
102439	AIR BARB FITTING	Used in TI section
10033403	ZR-100, DC-DC converter modification	DC/DC board
10030640	Cable Harness, ZR-100 Body	Main wire harness
10030903	ZR-100 Robot, Main Connector Wiring	Main robot connector plus wiring
10031351	ZR-100, MV Camera Wiring	MV Camera
10031353	ZR-100, LED Board Wiring	Machine vision camera lighting
10030905	ZR-100 Foot to I/O Wiring	
10030980	ZR-100, I/O to I/O Wiring	
10031282	ZR-100, Tool Interface I/O Wiring	
10031264	ZR-100, Tool Interface Input Wiring	
10049162	ZEC-SP-ZR-100-POD_HOT_SHOE_ASSY	Pod Hot Shoe spare part assembly
10036090	Tool Interface Center Prox Sensor Wiring	
10026593-1	TOOL CHANGER HOT SHOE ASSY	TI Hot shoe
10049162	ZEC-SP-ZR-100-POD_HOT_SHOE_ASSY	Pod hot shoe
10037770	CONTROL CABLE GUIDE	Hold main cable on to robot.
10031277	Top Plate Gasket	Gasket for ZR100 top plate with side mount screws. Robots manufactured before ~4/1/2012
10041737	Top Plate Gasket	Gasket for ZR100 top plate with top mount screws. Robots manufactured after ~4/1/2013
10030961	TOOL INTERFACE CAP GASKET	
104247	GASKET G10	used in main body, tool interface
10032590	Tool Interface Gasket	

10038769	Hot Shoe Gasket	Gasket for ZR100 top plate with side mount screws. Robots manufactured before ~4/1/2012
105773	LOCTITE 243 NUCLEAR GRADE 100ML	
110039	LOCTITE ADHESIVE - RED	
103442	EPOXY, HYSOL 608-CLEAR	
103459	ADHESIVE, LOCTITE 401	
112555	SEALANT RTV, BLACK ~ 103	

Controller – Tier 2

Part Number	Description	Details
10028704	PCBA, ZR-100 CONTROLLER	
10025684	POWER SUPPLY, 600W RH1	
108627	SWITCH, EMERGENCY STOP, RH1	
10034922	POWER ENTRY MODULE, IP65	AC module (Need to validate this is correct)
10035175	THRU PANEL RECEPTACLE, RJ-45 - Cat 5e	Ethernet port
10035877	BNC CONNECTOR, F/F PANEL MOUNT - 75 OHM	BNC ports 1 for MV camera and 1 for operator camera
10030879	ZR-100 CONTROLLER MAIN CONN. WIRING	Main connector and includes wiring
10033646	ZR-100, INSTALLATION CONN. WIRING	Aux connector and includes wiring
10034398	GASKET, CONTROLLER BASE	
10034366	AIR FILTER MOUNTING GASKET	
10014258-2	HOSE RETAINER, 3/8 OD Hose	
10035029	Air Hose, Blue 3/8 OD X 1/4 ID	

Install Hardware – Tier 2

Part Number	Description	Details
10029224	PCBA, ZR-100 I/O Module	1 in carriage. FW 1.2 is current rev for board.
103539	TUBING, NYLON TYPE H - 3/8 OD	Poly used for the installation anchors. 24 ft (12ft for each anchor) on the BOM.
10033930	HALL SENSOR TUBE SHEET LIMIT, Right	
10033931	HALL SENSOR TUBE SHEET LIMIT, Left	
10037770	CONTROL CABLE GUIDE	Hold install cable on to carriage
10035601	3-WAY TOGGLE VALVE, #10-32	Anchor airline toggle switch
10033832	SENSOR MOUNT, PROXIMITY	
10033802	GASKET, CARRIAGE WING BOX	
10033803	GASKET, CARRIAGE REAR CHASSIS	
10033801	GASKET, EE HOUSING	
10033804	GASKET, ACCESS COVER, EE HOUSING	
10035508	Connector Housing Gasket	
10036577	TIMING BELT, 45T	Carriage Belt. 2 per assembly

Toolhead – Tier 2

Part Number	Description	Details
10029224	PCBA, ZR-100 I/O Module	1 in DGT. FW 1.2 is current rev for board.
10032136	DGT Hot Shoe Wiring	
10037556	ZR-100, Toolhead I/O wiring, for 5v camera	Operator Camera
10034792	Hot Shoe Seal	
10031353	ZR-100, LED Board Wiring	Operator camera lighting
114356	GREEN EPOXY, 2 PART	required for putting sleeve on guide tubes
10038965	Timing Belt, 98T	Thinner DGT belt
10038966	TIMING BELT, 89T	Thicker DGT belt

Eddy Current Software Solutions

Steam Generator inspection

RevospECT® Pro (PC)

RevospECT Pro is the industry's first commercially available high-powered, adaptable and scalable automated analysis system. It provides end users the power and control to perform comprehensive automated analysis of eddy current data. RevospECT has a proven track record in the field and meets rigorous industry standards for flaw analysis from bobbin, rotating and array inspection techniques.

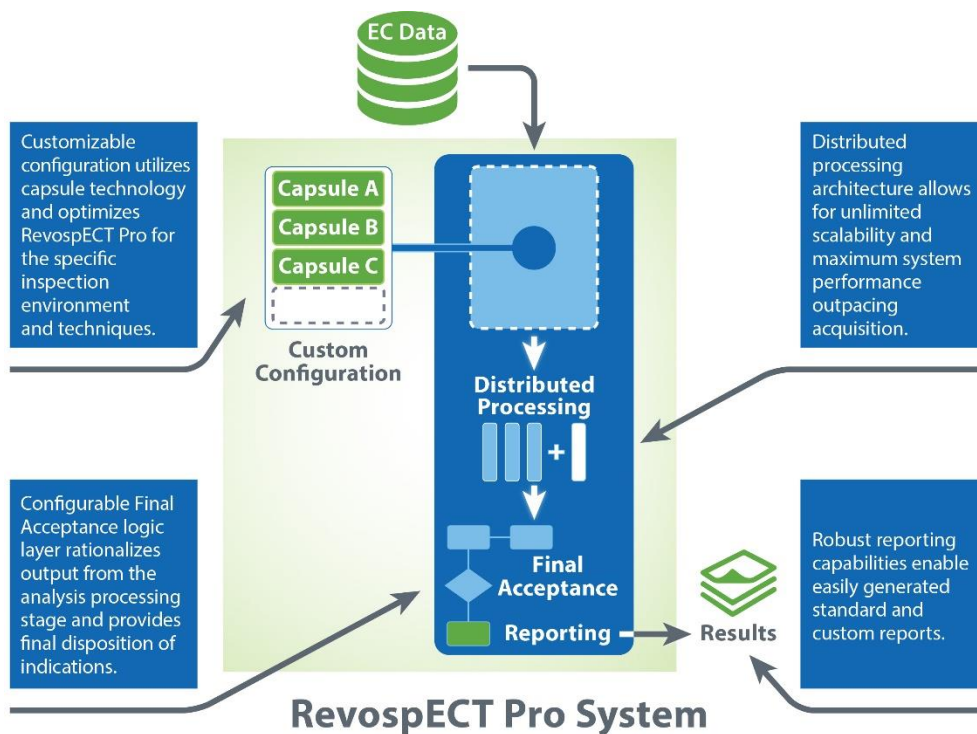

Cut Analysis Time & Resources

Automated analysis cuts time and resources required for inspections

- Fast distributed processing architecture
- Streamlined user interaction
- Utilizing less operators per robot

Improve Inspection Accuracy

Parameter based processing of signals guarantees repeatable accuracy

- Intrinsically independent analysis algorithms
- Full tube coverage through comprehensive configuration

- Backed by seven years of field deployment experience

Control from Start to Finish

The ability to lock down user configuration guarantees control over reporting results every time

- User defined configuration set-up process
- Flexible results reporting & exporting
- Integrates with existing systems & processes

EddyNet Software (PC)

Designed specifically for complex nuclear steam generator tube inspections, EddyNet PC delivers powerful performance. It benefits from the Windows OS to simplify network administration, file utilities use and printing operations. EddyNet PC can be utilized as a bundle, or as separate data acquisition, data analysis or data management modules.

EddyNet/AQ – Data Acquisition software

EddyNet/AQ has the features you need to run your eddy current instruments, probe pushers, and robotics for efficient data acquisition. It's tightly integrated with other EddyNet PC platform products.

Includes:

- Auto Acquire (AAS & Scripted AAS)
- MIZ-iD support
- PIMS (Probe Inventory Management)
- Data Stripper (X-Probe/Bobbin)
- Network Hardware Identification Utility
- Integrated Test Management

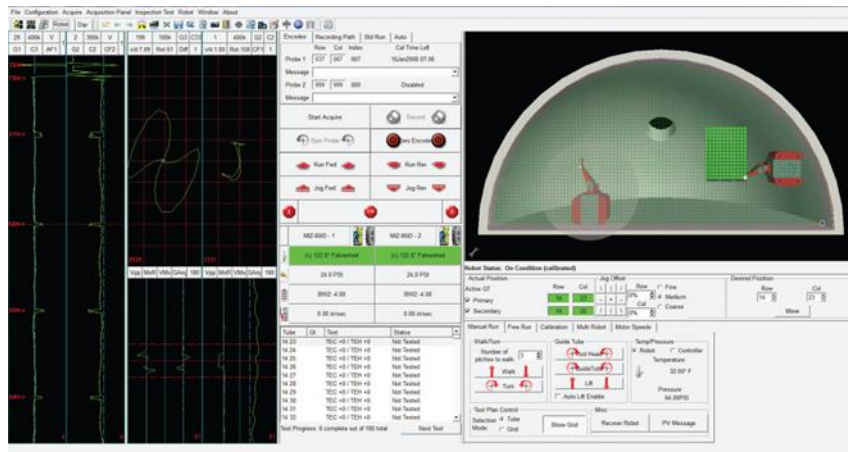

EddyNet/AN – Data Analysis software

EddyNet/AN has all of the necessary features to analyze, review and report on any eddy current data that you acquired during your inspection.

Includes:

- Bobbin, MRPC, Array Analysis

- Advanced C-Scan
- E-Resolution
- APTS
- Bobbin, Array, D-Probe Profile
- Multi-datafile comparison

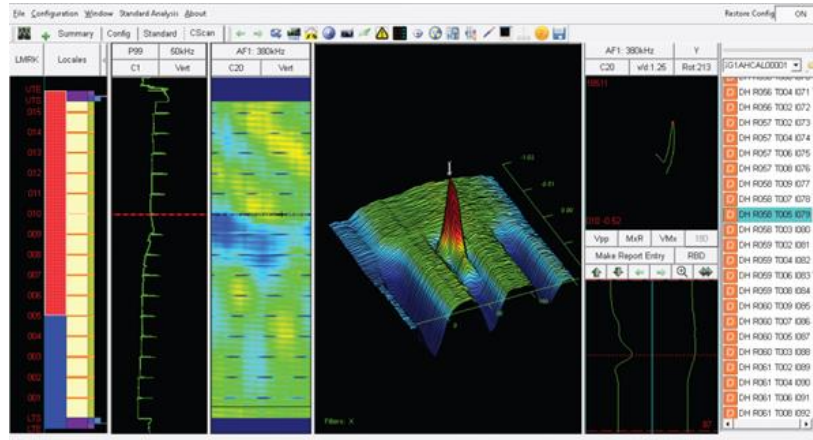

Eddynet/DM – Eddynet Data Management software

Eddynet/DM gives you the management functionality necessary to execute planning, tracking, and reporting on the eddy current data that was analyzed during your inspection.

Includes:

- Inspection Planning & Management
- Historical Management
- APTS
- Special Interest Test
- PID Test
- Test Plans and Scanner Tool
- Extent and Advanced Reporting Tools
- HMS/EIMS exports
- Cal-Board

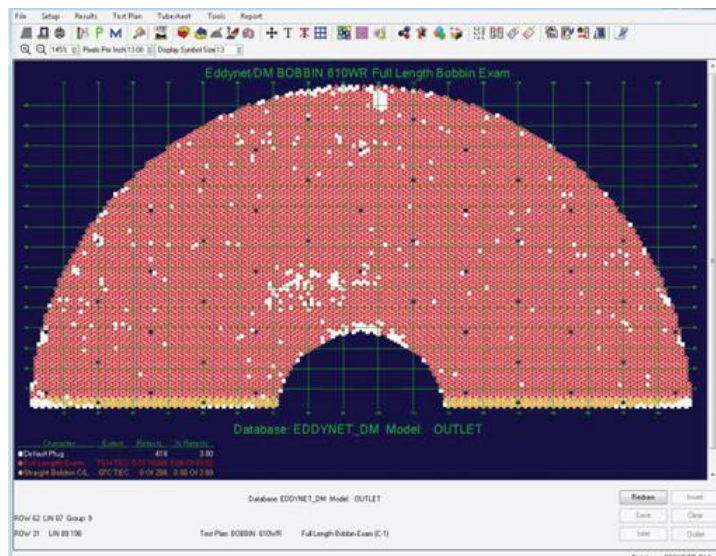

Eddynet/RevospECT Add-on Technologies

HDC®

Historical Data Compare (HDC) from Zetec is a technology that automates the process of retrieving and graphically aligning acquired EC data with historical data at same tube locations. Comparing current inspection data with the historical view is a standard practice on all inspection jobs but is tedious, time consuming, and carries risk of human error. Zetec HDC® technology automates and streamlines this function.

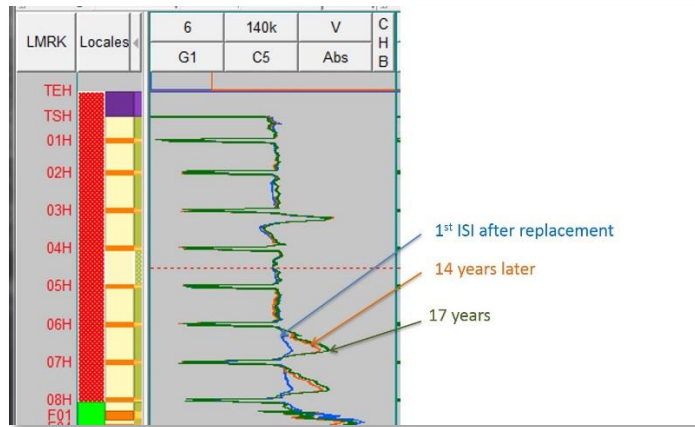

Eddynet Signal InjECT

Coming soon – summer of 2016 (Note: this product will not be available in the U.S.)

Eddynet Signal InjECT is the industry’s most advanced tool for creating and editing eddy current signal data files. It allows users to repurpose existing data for other value-added applications such as creation of SSPD exams, automation performance testing, analyst training, and more. It is fully integrated into the Eddynet/AN product yet has a full set of independent easy to use features and controls for the capture, paste, and manipulation of bobbin, MRPC and array data.

Zetec Part Number	Product Name	Description
10035609	Eddynet/AN	1 year license-to-use of Eddynet AN manual analysis
10037946	Eddynet/AQ	1 year license-to-use of Eddynet AQ acquisition
10039268	Eddynet/AQ plus DQV	1 year license-to-use of Eddynet AQ acquisition plus DQV (Data Quality Verification)
10037975	Eddynet/DM	1 year license-to-use of Eddynet DM Data Management
REVOPRO-001	RevospECT Pro	Per job license use of RevospECT Pro Automated Analysis software
Eddynet PC Software Products		www.zetec.com/products/eddy-current/software-ec/eddynet-pc-products/
RevospECT Pro Software		www.zetec.com/products/eddy-current/software-ec/revospECT-pro/
Software Service Program		www.zetec.com/products/eddy-current/software-ec/eddynet-pc-products/eddynet-pc-software-service-program/

BOP/HX applications

Velocity Software (PC)

Built on the Eddynt architecture, Velocity has been customized to the balance-of-plant (BOP) / heat exchanger (HX) market, bringing the same acquisition, analysis and management of data functionality as our popular Eddynt software.

Our Velocity PC Software is the most efficient tool you can use for data acquisition, analysis and management. It has been customized for the balance-of-plant (BOP) and heat exchanger (HX) markets. It's easy to use, offering you improved analysis data filtering capabilities.

Velocity operates via three modules for each activity –

- Velocity/AQ for data acquisition
 - Auto Acquisition (AAS & Scripted AAS)
 - Network Hardware Identification Utility
 - Integrated Test Management

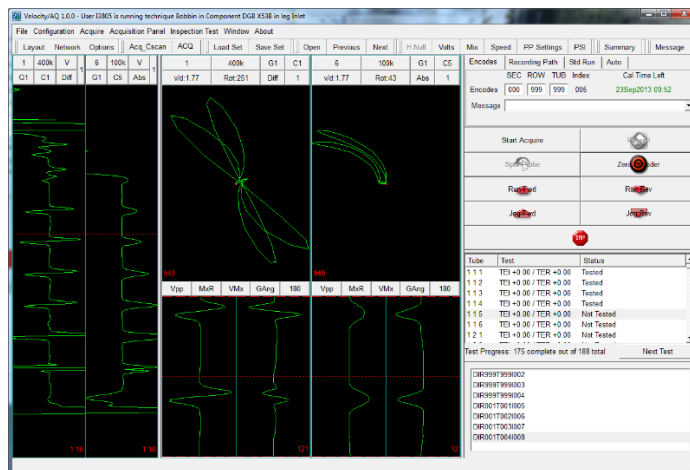

- Velocity/AN for data analysis
 - Bobbin, MRPC and Array Analysis
 - Enhanced C-Scan
 - E-Resolution
 - Multi-datafile Comparison
 - One all-inclusive DB per component

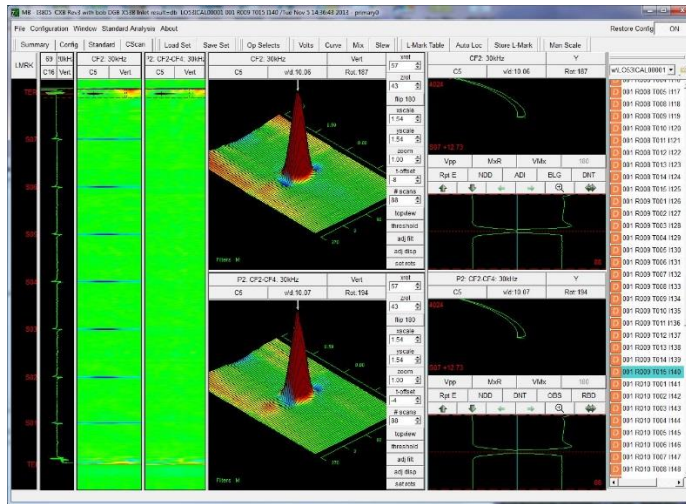

- Velocity/DM for data management
 - Inspection Planning and Management
 - Historical Data Management
 - Test Plans
 - PID Test
 - Extent reporting tool
 - Auto Closeout Reporting

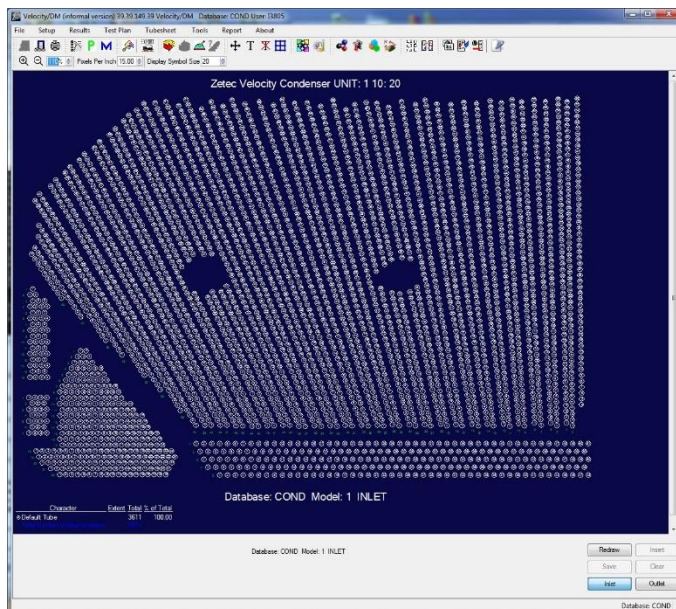

Each product has been perfected with the support of decades of experience in the BOP and steam generator eddy current inspections.

Benefits of Velocity Software

Broad Compatibility

Velocity software is compatible with a wide range of instruments, probes and pushers, including:

- MIZ-200
- Bobbin probes
- 3D & 10D pushers

Useful Acquisition

- Get more efficient data acquisition through your inspections with Velocity’s Auto Acquire.

Expert Analysis

- Gain better understanding of your data through an improved locating feature, report editor enhancements, and comparisons to competitor data.

Data Control

- Manage your data via advanced reporting tools, live interaction and updating, and user-defining of watermark use.

Zetec Part Number	Product Name	Description
10047951	Velocity/AN	Customer owned license of Velocity AN for analysis
10048849	Velocity/AN with Key	With Hardware key licensing
10049901	Velocity/AN+CSCAN	Customer owned license of Velocity AN + CSCAN
10049900	Velocity/AN+CSCAN with Key	With Hardware key licensing
10047952	Velocity /DM	Customer owned license of Velocity DM for data management
10048850	Velocity/DM with Key	With Hardware key licensing
10052906	Velocity Bundle	Customer owned license of Velocity bundle all three products
10048851	Velocity Bundle with Key	With Hardware key licensing
Velocity Software		www.zetec.com/products/eddy-current/software-ec/velocity/
Software Service Program		www.zetec.com/products/eddy-current/software-ec/eddynet-pc-products/eddynet-pc-software-service-program/

Software Service Program (SSP)

Zetec is committed to continuous improvement of the PC based software products and to introduce new features that will improve system performance and reliability. Customers that subscribe to the Eddynet or Velocity PC Software Service Program (SSP) will benefit from access to annual or semi-annual product releases addressing software bugs, new features, and improved functionality.

EDDYNET/VELOCITY SSP – BENEFITS

All customers owning an SSP contract for their software products are entitled to:

- Access to all current updates, enhancements, and bug fixes for the current Eddynet/Velocity PC software version
- Online access to SSP self-service web portal including:
 - Self-service licensing
 - Software downloads
 - Software bulletins

Annual review by an Eddynet/Velocity specialist to discuss performance, potential issues, and suggestions for new features

To access the SSP website use your Internet Licensing Distribution System (ILDS) account to login. go to <http://ssplicensing.zetec.com>

EDDYNET/VELOCITY SSP – CONDITIONS

Requires an active subscription to maintain access to the SSP benefits

The purchase of any new Eddynet license automatically provides 1st year SSP subscription, free of charge

The SSP period is one year from the date of purchase. Zetec will send a personalized SSP renewal quotation to each customer approximately one month prior to expiration of the SSP

Customers skipping a year of SSP subscription can become current by remitting the unpaid prior year(s) fees

Zetec offers attractive upgrade opportunities for current Eddynet HPUX customers to transition to Eddynet PC. Contact Zetec sales or customer service for more information.

Suggested hardware to run the EC software

Eddynet® PC Hardware/Software Recommended Specifications

In preparation for the use of Zetec Eddynet PC software, the following information provides a guide to be used in the selection of computer hardware for compatibility with the PC Windows version of the Eddynet software products.

Processor: Minimum 2.4GHz multi-core processor.

NOTE: With all Zetec and support applications' running on one PC the recommended minimum is a single quad core processor at a minimum of 2.4GHz.

Operating System: Microsoft Windows 7 Ultimate or Microsoft Windows 7 Enterprise

- Zetec has validated the product to work on Windows 7. Windows 7 is the operating system currently preferred by the majority of our customers. Please contact Zetec to express interest in a **Windows 8** solution.

- 64-bit or 32-bit Operating System, recommend 64-bit.

RAM: 8GB (Recommended minimum - 4GB)

Secondary Storage:

- Minimum 2GB of available secondary storage space for installation. Additional space as required for data storage. Recommend minimum 500GB.
- The storage device should meet or exceed the following Data Transfer Rates
- Internal data transfer rate 1200 Mbits/sec max
- Sustained data transfer rate OD 100 Mbytes/sec max
- I/O data-transfer rate 300 Mbytes/sec max

Media Drive: CD/DVD-ROM drive

Display Monitor(s): 1,600 x 1200 resolution or better with display screen size set to 100% (default)

Graphics Card: Minimum of 256MB video memory, single DVI/VGA (Dual DVI/VGA recommended for acquisition stations)

☑ **Network:** Single, minimum 100Mbit/sec Ethernet Network Card

Eddy Current Probes

Table of Contents

ECT Probe Introduction.....	128
Probe Description Information.....	130
Probe Selection Recommendations.....	146
Bobbin Probes	148
Array Probes	170
MRPC Probes	183
Motor Units	194
Encircling Probes	203
Handheld Probes	205
Surface Array Probes	208
Ferrous Tubing Probes	209
Calibration Standards	214
MIZ-21C Probes & Accessories	215

ECT Probe Introduction



Tubing Array Probes



Bobbin Probes



Rotating Probes



Handheld Probes



Calibration Standards



Adapters

Probe Solutions for all Industries

Since 1968, the experts at Zetec have designed over 10,000 probes to meet the constantly expanding technological needs of our NDT clients.

We offer a wide selection of eddy current and other electromagnetic probes.

Bobbin probes for non-ferromagnetic tube inspections



X-Probe and CXB multi-coil array probes to quickly detect and characterize all flaws, including circumferential cracks



Rotating (MRPC) probes to detect and characterize all flaws at expansion, in small radius U-bends, in tube plugs and in repair sleeves



Remote Field probes for inspection of high permeability tubing and pipe

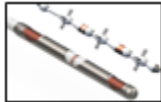

Carter and TEO probes for inspection of mildly ferritic tubes such as Monel, SEA-CURE and 400 series stainless steel



Handheld probes for inspecting turbine blades, welds and more



If you don't find the product you are looking for, do not hesitate to email Zetec Customer Service: customerservice@zetec.com to discuss your particular needs.

Probe Description Information

Zxxx-xxxxxx-Exx.xxx-xxx-xxB1x00-0.000

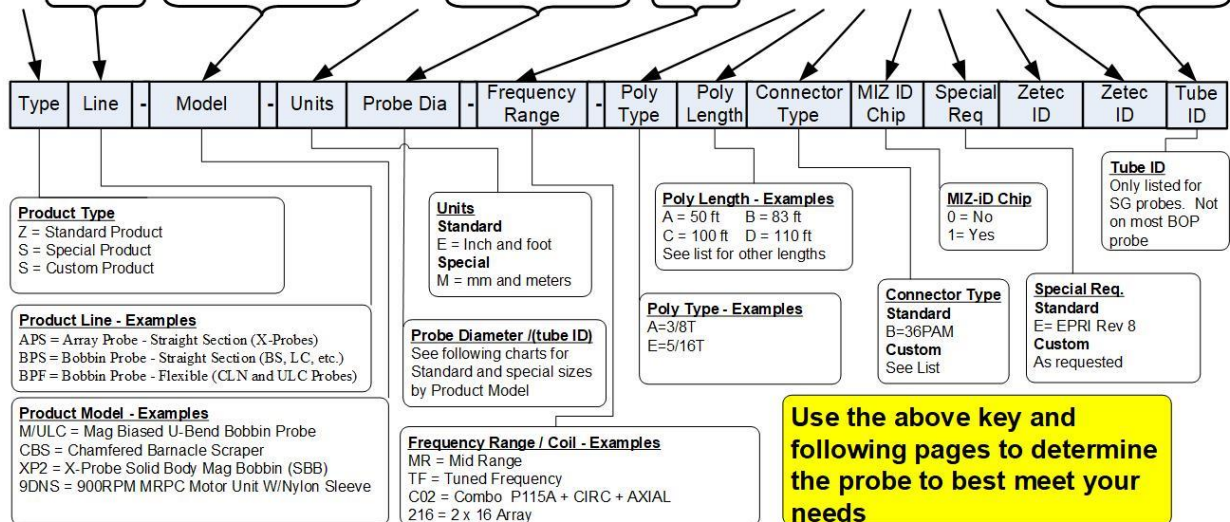

Example

ZAPF-XP2-E00.560-216MR-ADB1E01-0.608

The Above Probe is an X-probe with mag biased bobbin (XP2), in English Units (E), with a diameter of .560" (00.560); 2X16 array coils and a mid range frequency bobbin (216MR), with 3/8T poly type (A), 110 ft in length (D), a 36 pin connector (B), ID chip that stores and transmits probe data (1), tested to EPRI REV7 requirements (E); and is made for a tube with an ID of 0.608 inches.

The above figure demonstrates what each piece of information means in the probe description.

The following lists provide most of the available options for each of the above items.

Product Line

Z**xxx**-xxxxxx-Exx.xxx-xxx-xxB1x00

Product Line	Description
APS	Array Probe - Straight Section
APF	Array Probe - Flexible
BPS	Bobbin Probe - Straight Section
BPF	Bobbin Probe - Flexible
BPR	Bobbin Probe - Reference
CPS	Tight Bend (Combo) Bobbin Probe - Straight Section
CPF	Tight Bend (Combo) Bobbin Probe - Flexible
BPA	Bobbin Probe - Accessories
MUS	Motor Unit - Straight Section
RPS	Rotating Probe Head - Straight Section
RPF	Rotating Probe Head - Flexible
RES	Rotating Extension Shaft
TDS	Tube Drive Shaft
MPA	MRPC Probe - Accessories
HHP	Handheld Probe w/Cable
HHD	Handheld Detachable Probe w/o Cable
HHA	Handheld Probe Accessories
HHC	Handheld Probe Adaptor Cable
ES	Surface Array Probe
UT	Ultra-Sonic Probe

Model Information

Zxxx-xxxxxx-Exx.xxx-xxx-xxB1x00

Go to the specific probe catalog models to get model information

Diameter

Zxxx-xxxxxx-Exx.xxx-xxx-xxB1x00

Most probes have diameter offerings in .010" increments
See Zetec's Product Catalog for diameter offerings for specific models.
Other sizes are available upon request

Coil Frequency Information

Zxxx-xxxxxx-Exx.xxx-MR-xxB1x00

Coil	Coil Description
NMR	Narrow Groove MR Coil Winding
NHF	Narrow Groove HF Coil Winding
NTF	Narrow Groove TF Coil Winding
LF	LF Coil Winding
ULF	ULF Coil Winding
MR	MR Coil Winding
HF	HF Coil Winding
UHF	UHF Coil Winding
TF	TF Coil Winding
SAX	French SAX Bobbin Winding
	Combo Coil Sets
C01	Combo P115A + PP11A + SP080B
C02	Combo P115A + AXIAL + CIRC
C03	Combo SP080A + AXIAL + CIRC
C04	Combo MP115A + MPP11A + MSP080B
C05	Combo P115A + PP11A
C06	Combo PP11C + PP16B
C07	Combo MPP11C + MPP16B
C08	Combo PP11A + SP080B
C09	Combo P115A + PP11A + P115E
C10	Combo SP080B + SP060B + SP040B
C11	Combo PP9A + PP14A
C12	Combo SP080A + PP11A
C13	Combo PP11A + PP9A

Coil	Coil Description
C14	Combo PP11A + PP16A
C15	Combo SP080E + SP060E + SP040B
C16	Combo SP080B + SP060F + SP040C
C17	Combo PP11A + SP060F + P115A
C18	Combo GAP SCAN
C19	Combo SP080A + PP11A + AXIAL
C20	Combo P115A + PP11A + Dummy Shoe
C21	Combo PP10C + Dummy Shoe
C22	Combo P115A + PP11K + Dummy Shoe
C23	Combo P080F + P100G
C24	Combo PP16A + P100D + SP080B
C25	Combo PP11A + Dummy Shoe
C26	Combo P116A + PP16A + SP080B
C27	Combo PP10A + Dummy Shoe
C28	Combo PP10E + Dummy Shoe
C29	Combo P115A + PP11G + SP080B
C30	Combo SP080B + PP11A + P115A
C31	Combo P115A + PP9A + SP080B
C32	Combo P116A + PP9A + SP080B
C33	Combo PP11A + PP9A + SP080B
C34	Combo PP11A + Circ Sensitive D/P Pancakes + Profiling pancake
C35	Combo MP115A + MPP11A, with magnets
C36	Combo PP9A + Point Coil with Magnet/P080A Pancake Coil
C37	Combo PP9A + Point Coil with Magnet/P080J Pancake Coil
C38	Combo PP11A, PP11A rotated 45° and P080A
	Pancake Coils
P035A	Pancake Coil 035A
P060A	Pancake Coil 060A
P077A	Pancake Coil 077A
P080A	Pancake Coil 080A
P091A/SD	Pancake Coil P091A receives driven by sheet drive
MP080A	Pancake Coil 080A, with magnet
C/P080A	CIRC Pancake Coil 080A
A/P080A	AXIAL Pancake Coil 080A
P080B	Pancake Coil 080B
MP080B	Pancake Coil 080B, with magnet
SP080A	Shielded Pancake Coil 080A
P080C	Pancake Coil 080C
C/P080G	CIRC Pancake Coil 080G
A/P080G	AXIAL Pancake Coil 080G
P084C	Pancake Coil 084C

Coil	Coil Description
P090E	Pancake Coil 090E
P090B	Pancake coil 090B
P110A	Pancake Coil 110A
P110B	Pancake Coil 110B
P110E	Pancake Coil 110E
P115A	Pancake Coil 115A
MP115A	Pancake Coil 115A, with magnet
P115E	Pancake Coil 115A
	+Point Coils
PP9A	+ Point Coil 9A - 300-1000 kHz
MPP9A	+ Point Coil 9A with magnet, 300-1000kHz
PP9B	+ Point Coil 9B - KHZ
PP9C	+ Point Coil 9C - KHZ
PP9G	+ Point Coil 9G - KHZ
PP9H	+ Point Coil 9H - KHZ
PP9J	+ Point Coil 9J - KHZ
PP10B	+Point Coil
PP11A	+ Point Coil PP11A
MPP11A	+ Point Coil PP11A Magnet
PP11C	+ Point Coil PP11C - KHZ
PP11E	+ Point Coil PP11E - 20-200 KHZ
PP11G	+ Point Coil PP11G - 10-200 KHZ (50kHz Peak)
PP11K	+ Point Coil PP11K - KHZ
PP14A	+ Point Coil 14A
MPP14A	+ Point Coil PP14A Magnet
PP16C	+ Point Coil 16C - KHZ
PP17A	+ Point Coil 17A - KHZ
PP19A	+ Point Coil 19A - KHZ
PP20A	+ Point Coil 20A - 30-300 KHZ
MPP20A	+ Point Coil 20A Magnet - 30-300 KHZ
PP21B	+ Point Coil 21B - KHZ
PP29B	+ Point Coil 29B - KHZ
	Block +Point Coils
PPB5A	Block + Point Coil 5A - 50-600 KHZ
	Dummy
DS	Dummy Shoe
	X-Probe Coils
112	1x 12 No Bobbin

Coil	Coil Description
112LF	1x 12 Array/Low Frequency Bobbin
112MR	1x 12 Array/Mid Frequency Bobbin
112TF	1x 12 Any custom bobbin coil winding
112HF	1x 12 Array/High Frequency Bobbin
114	1x 14 Array
114LF	1x 14 Array/Low Frequency Bobbin
114HF	1x 14 Array/High Frequency Bobbin
114MR	1x 14 Array/Mid Frequency Bobbin
114TF	1x 14 Array/Tuned Frequency Bobbin
116	1x 16 Array
116LF	1x 16 Array/Low Frequency Bobbin
116MR	1x 16 Array/Mid Frequency Bobbin
116HF	1x 16 Array/High Frequency Bobbin
119HF	1x 19 Array/High Frequency Bobbin
119MR	1x 19 Array/Mid Frequency Bobbin
119LF	1x 19 Array/Low Frequency Bobbin
124HF	1x 24 Array/High Frequency Bobbin
124MR	1x 24 Array/Mid Frequency Bobbin
127HF	1x 27 Array/High Frequency Bobbin
127MR	1x 27 Array/Mid Frequency Bobbin
202A	2x 2 Array Simulating X-Probe
208	2x 8 Array
208LF	2x 8 Array/LF Bobbin
212	2x 12 Array
212MR	2x 12 Array/Mid Frequency Bobbin
212TF	2x 12 Array/Tuned Frequency Bobbin
212HF	2x 12 Array/High Frequency Bobbin
214	2x 14 Array
214LF	2x 14 Array/Low Frequency Bobbin
214MR	2x 14 Array/Mid Frequency Bobbin
214TF	2x 14 Array/Tuned Frequency Bobbin
214HF	2x 14 Array/High Frequency Bobbin
216	2x 16 Array
216LF	2x 16 Array/Low Frequency Bobbin
216MR	2x 16 Array/Mid Frequency Bobbin
216TF	2x 16 Array/Tuned Frequency Bobbin
216SAX	2x 16 Array/SAX bobbin
216HF	2x 16 Array/High Frequency Bobbin
219	2x 19 Array
219MR	2x 19 Array/ Mid Frequency Bobbin
219TF	2x 19 Array/Tuned Frequency Bobbin

Coil	Coil Description
219HF	2x 19 Array/High Frequency Bobbin
219LF	2x 19 Array/Low Frequency Bobbin
219SAX	2x 19 Array/SAX Bobbin
308	3x 8 Array
308MR	3x 8 Array/Mid Frequency Bobbin
312	3x 12 Array
312MR	3x 12 Array/Mid Frequency Bobbin
312TF	3x 12 Array/Tuned Frequency Bobbin
316	3x 16 Array
316TF	3x 16 Array/Tuned Frequency Bobbin
	RG3-4 Coils
CC46E	Surface Transmit and Receive - 3 Coil
	RPS Coils
CC52F	Non-Surface Transmit and Receive - 3 Coil - 50-500 kHz
CC52H	Non-Surface Transmit and Receive - 3 Coil - 20-200 kHz
CC52G	Non-Surface Transmit and Receive - 3 Coil - 5-50 kHz
	Deep River Coils
CC5W	50–500 kHz with Carter1 magnet configuration
CC14R.	10-100 kHz with Carter1R radial field magnet configuration
CC14L	Carter1R radial field magnet configuration
CC14Y	Deep River Coil
CC14W	Deep River Coil
CC14AA	Deep River Coil
CC18D	Carter1P magnetic bobbin partial saturation configuration
CC22J	Carter1P magnetic bobbin partial saturation configuration
CC40S	49.1 uH Carter1 magnet configuration
CC40T	42 uH Carter1 magnet configuration
CC40W	Deep River Coil
CC40X	Deep River Coil
CC43X	50-500 kHz with A/CFI configuration
CC48B	Deep River Coil - Bobbin
CC52F	Deep River Coil - 4 Coil
CC52J	Deep River Coil - 3 Coil
CC58C	20-400 kHz with Carter1R radial field magnet configuration
CC58P	50-500 kHz with Carter1 reverse magnet configuration
CC58U	50-500 kHz with Carter1 reverse magnet configuration
CC62A	20-400 kHz with Carter2 magnet configuration

Coil	Coil Description
	TEO/TEG Coils
005	1-10 kHz
010	2-20 kHz
015	3-30 kHz
025	5-50 kHz
030	6-60 kHz
050	10-100 kHz
075	15-150 kHz
100	20-200 kHz
125	25-250 kHz
150	30-300 kHz
250	50-500kHz
300	60-600 kHz
500	100-1000 kHz
600	120-1200 kHz
	Surface Coils
SC062A	Split-Core Coil SC062A
SC067A	Split-Core Coil SC067A
SC106A	Split-Core Coil SC106A
SC115A	Split-Core Coil SC115A
SC260A	Split-Core Coil SC260A
SC260B	Split-Core Coil SC260B
CS01	Combo Conical Split Core Coil (CSC) CSC089A + CSC089B
DS119A	Diff Driver-Up Split Core Coil (D-DPUSC119A)
DPU	Driver Pick-up
	Analog Magnetic Sensors
AMS	Analog magnetic sensor
	RFT Coils
085	20 Hz to 200 Hz used for carbon steel thicker than 6mm
.3K	100 Hz to 1000 Hz used for carbon steel applications like SA214 or SA179
02K	1 kHz to 10 kHz used for thin or lower permeability carbon steel like A-556
15K	5 kHz to 30 kHz used for ferromagnetic stainless steel like SS439 (A-268) or SEA-Cure
	Array Coils and Configuration
02x016/P101B	2x16 coil array using P101B pancake coils

Poly Type

Zxxx-xxxxxx-Exx.xxx-xx-**A**xB1x00

Poly Type	Description
0	None
A	3/8T
B	3/8H
C	3/8HDPE-T
D	3/8HDPE-H
E	5/16T
F	5/16H
G	**OBS**5/16HDPE-T
H	5/16HDPE-H
I	1/2 BLK
J	11mm HDPE
K	1/4 Nylaflo LM
L	4mm Flat Wound Shaft
M	1/2 Tygon
N	7/16 Tygon
O	3/8 Tygon
P	3/8 Solid Shaft
Q	7mm Nylon
R	1/4T
S	1/8T
T	5/16 Nylaflo LM
U	320HDPE
V	3/8 Solid Shaft - LL
W	3/16T
X	13.85 mm HDPE
Y	3/16H
Z	3/8HS
#	Special

Poly Length – Probes and Motor Units

Zxxx-xxxxxx-Exx.xxx-xx-x**A**B1x00

Most models provide recommended standardized lengths. Nearly every length can be provided upon request

General	Probe and MU Poly Lengths	Note: M/ULC/Cx and ULC/Cx “tight bend probes” have different formatting for the probe lengths
0	No cable	
A	50ft (15m)	The D means: SCPF-ULC/C4-E00.480-MR-ADB1E00: 110ft poly, plus 4ft combo section: 114ft total
B	83ft (25m)	
C	100ft (30.5m)	The N means: ZCPF-M/ULC/C4-E00.610-TF-ANB1E00-0.664: 106 ft poly, plus 4ft combo section: 110ft total
D	110ft (33.5m)	
E	45ft (13.5m)	
F	40ft (12m)	
G	96ft (29m)	
H	65ft (20m)	
I	90ft (27.5m)	
J	105ft (32m)	
K	80ft (24.5m)	
L	98ft (30m)	
M	99ft (30m)	
N	106ft (32.5)	
O	107ft (32.5m)	
P	85ft (26m)	
Q	30ft (9m)	
R	120ft (36.5m)	
S	6ft (2m)	
T	25ft (7.5m)	
U	75ft (23m)	
V	60ft (18.5m)	
W	130ft (39.5m)	
X	125ft (38m)	
Y	70ft (21.5m)	
Z	35ft (10.5m)	
#	Special	
2	13ft(4m)	

Length – MRPC Probe Heads and Extension Shafts

Zxxx-xxxxxx-Exx.xxx-xx-xEB1x00

MRPC	Probe Lengths
O	No cable
A	72 in
B	108 in
C	156 in
D	180 in
E	18 in
F	24 in
G	36 in
H	48 in
I	60 in
J	90 in
K	96 in
L	50 in
M	12 in
N	72 in
O	4 in
P	6 in
Q	8 in
R	2.5 in
S	3.5 in
T	45 in
U	35 in
V	30 in
W	68 in
X	75 in
Y	53 in
Z	38 in
#	Special

Connectors – Probe and Motor Unit to Instrument

Zxxx-xxxxxx-Exx.xxx-xxx-xxA1x00

General	Probe / MU Connectors
0	N/A
A	4 Pin Amphenol
B	36 Pin Amphenol
C	2x BNC
D	6 Pin Amp/3 Pin Amp
E	6 Pin Amp/5 Pin Bendix
F	10 Pin Amp/5 Pin Amp
G	4 Pin Micro-Tech
H	5 Pin Lemo
I	10 Pin Amphenol
J	16 Pin Lemo
K	4 Pin Fischer
L	10 Pin Insert
M	26 Pin - Aero
N	1 Pin Lemo
O	2 Pin Lemo
P	36 Pin Amp/6 pin Jaeger
Q	4x BNC
R	3 each Twinax #12
S	19 Pin Amphenol
T	5 Pin Cannon
U	27 Pin Connector
V	6 Pin Jaeger
W	41 Pin IT Cannon
X	6 Pin Jaeger/ 41 Pin IT Cannon
Y	8 Pin ITT cannon
Z	2 MCX Connectors
2	64 pin MIZ-200
#	Special

Connectors – MRPC Probe Head to Motor Unit

Zxxx-xxxxxx-Exx.xxx-xxx-xxA1x00

MRPC	Probe Connectors
O	N/A
A	10 Pin Insert to 5/2 Pin Insert
B	64 Pin MIZ-200 Surface Array Connector
C	128 Pin MIZ-200 Surface Array Connector
D	
E	
F	
G	5/2 Pin Insert
H	3 Pin Insert
I	5/2 to 5/2 Pin Insert
J	5 Pin Lemo to 5/2 Pin Insert
K	5 Pin Lemo
L	5 Pin Insert
M	12 Pin Omnetic
N	5 Pin Omnetic
O	
P	
Q	4 Pin Lemo
R	7 Pin Lemo
S	4 Pin Micro-Tech
T	
U	
V	27 Pin Connector
W	
X	10 Pin Insert
Y	
Z	1 Pin Female Triaxial Connector
#	Special

MIZ-iD Technology

Zxxx-xxxxxx-Exx.xxx-xxx-xxx1x00

The "1" indicates the probe head has MIZ-iD technology. You can remotely get the probe part number, description and serial number if you are using Zetec software and instruments. The MIZ-iD technology also ensures the correct tuning parameters are used when setting up motor units.

Special Requirements

Zxxx-xxxxxx-Exx.xxx-xxx-xxxxE00

Special Testing	Description
0	Standard Manufacturing Quality Check
E	Meets the requirements of US detrimental materials and EPRI PWRSG Guidelines rev 8
F	Meets the requirements of French chemical PMUC and EPRI PWRSG Guidelines rev 8
K	Meets the requirements of French chemical PMUC
D	Meets the requirements of EPRI PWRSG Guidelines rev 8
N	Meets the requirements of US Navy detrimental materials and EPRI PWRSG Guidelines rev 8
#	Customer Specific Requirements

Motor Unit Tuning Parameters

Zxxx-xxxxxx-Exx.xxx-xxx-xxxxAA0

MU Tune	Model: Motor Position-Item #/Brushed
00	Motor tuning not defined
AA	9D: M1-101281/M2-101294/Y
AB	12Q: M1-101283/M2-101293/M3-101296/Y
AC	HT: M1-101285/M2-101296/Y
AE	24S: M1-105984-1/N
AF	24S: M1-107381/N
AG	9S: M1-109232/N
AH	3S: M1-101252/Y
AI	HT: M1-105107/M2-101294/Y
AJ	3S: M1-101250/Y
AK	16S: M1-10028927/Y

MU Tune	Model: Motor Position-Item #/Brushed
AL	TDSMUW: M1-105764/M2-101294/N
AM	3S: M1-101253/Y
AN	3S: M1-101258/Y
KA	9D: M1-101281/M2-101294/Y; Meets French PMUC materials
KB	12Q: M1-101283/M2-101293/M3-101296/Y; Meets French PMUC materials
KC	HT: M1-101285/M2-101296/Y; Meets French PMUC materials
KE	24S: M1-105984-1/N; Meets French PMUC materials
KF	24S: M1-107381/N; Meets French PMUC materials
KG	9S: M1-109232/N; Meets French PMUC materials
KH	3S: M1-101252/Y; Meets French PMUC materials
KI	HT: M1-105107/M2-101294/Y; Meets French PMUC materials
KJ	3S: M1-101250/Y; Meets French PMUC materials
KK	16S: M1-10028927/Y; Meets French PMUC materials
KL	TDSMUW: M1-105764/M2-101294/N; Meets French PMUC materials
KM	3S: M1-101253/Y; Meets French PMUC materials
KN	3S: M1-101258/Y; Meets French PMUC materials

Probe Selection Recommendations

Probe Model Selection

Review the catalog to determine the best model to meet your specific needs.

Array Probes

If circumferential cracks and speed are components of your inspection, use Zetec's industry leading array probes.

MRPC Probes and Motor Units

For detailed evaluation and flaw sizing in tubing, Zetec has the most complete line of rotating probes.

Bobbin Probes

Zetec's high quality bobbin probes allow for quick and accurate inspections in a wide range of tube sizes, materials, lengths and geometries (bends or fins).

Magnetic Permeability Variations (Non-magnetic Tubing)

If there are variations in the magnetic permeability of the tubing, select a magnetically biased probe. Mag biased probe options are available in nearly all bobbin and MRPC probe head options.

Tight Bends

Zetec makes a wide range of probes for tight bends in the tubing. Whether it's a bobbin, array or MRPC probe head with extension shafts, we have the probe that will allow inspection in every area of the tube.

Probe Motor Units and MRPC Probe Heads

If you have MIZ8X instruments, you should always select motor units with the 36 pin connector. These motor units have MIZiD memory chips. MIZiD chips allow the MIZ8X motor control settings to be tuned automatically. Incorrect MIZ8X motor control settings will cause poor motor performance and may cause the instrument to be damaged.

When selecting the probe head for the motor unit it is important to ensure the probe head connector matches the mating connector on the motor unit.

Probe Outside Diameter

Fill factor (probe outside diameter² / tube inside diameter²) is not a good method for determining the optimum probe diameter. Typically, you want a probe outside diameter 0.040" to 0.050" (1.016 to 1.27 mm) smaller than the tube inside diameter. Using the same fill factor across all sizes can lead to oversized probes for small tubing and undersized probes for larger tubing.

Probes used in tubing with impediments, dents, tight radius bends or ovalization may need to have a smaller outside diameter.

Probes are typically provided in 0.010" (0.25 mm) outside diameters increments. Standard outside diameter ranges are listed for each model in the catalog. Larger or smaller diameters are available upon request.

Probe Length

Standard lengths are listed in the catalog for each probe model. It is recommended to order the shortest standard length that will cover the required inspection distance. Custom lengths can be provided for all sizes.

Probe Push/Pull Poly

The push/pull tube (poly) is what pushes and pulls the probe coils through the tube. If the probe must navigate bends, you should select the most pliable poly that will not kink. Poly sizes are typically followed with a “T” (thin) or and “H” (heavy). The “H” is the thickest wall, and therefore the strongest poly. It should be used when significant push force is required. As the diameter of the poly increases, the strength increases, but it becomes more difficult to push around bends.

Standard poly options are listed in the catalog for various probe models. There are also dozens of custom options available.

Probe Connector

Choose the connector that works with the instrument you are using. Using adapters may lead to a decrease in the data quality. Zetec’s 36 pin connectors also provide MIZiD information. The probe part number, description and serial number information can be presented electronically via Zetec’s software. MIZiD also automatically sets the tuning parameters for motor units. Using an incorrect motor unit tuning parameter has led to damaged instruments.

Probe Coil / Frequency Selection

For best results choose a probe coil type that has a frequency range that is suitable for the thickness and electrical resistivity of the material being inspected. Contact Zetec to optimize the coil for your application.

Non-Magnetic Tube Inspection

Bobbin Probes



Thimble tube, M/ULC, Carter, TEO, RFT and BS Bobbin Probes

The term “bobbin” is used to describe probes with a cylindrical form having coils wound around the circumference.

Most bobbin probes have two coils that are connected to an eddy current instrument differential input. When both coils are in flaw free or identical areas, there is no difference in what each coil senses and no differential signal produced. When one coil is near a flaw, dent, inclusion or other anomaly and the other is in normal material, a coil response is produced.

If the eddy current instrument can generate a reference signal or if a reference probe is used, an absolute flaw signal will also be produced by utilizing only one of the two coils. The absolute signal is used to detect more gradually occurring anomalies.

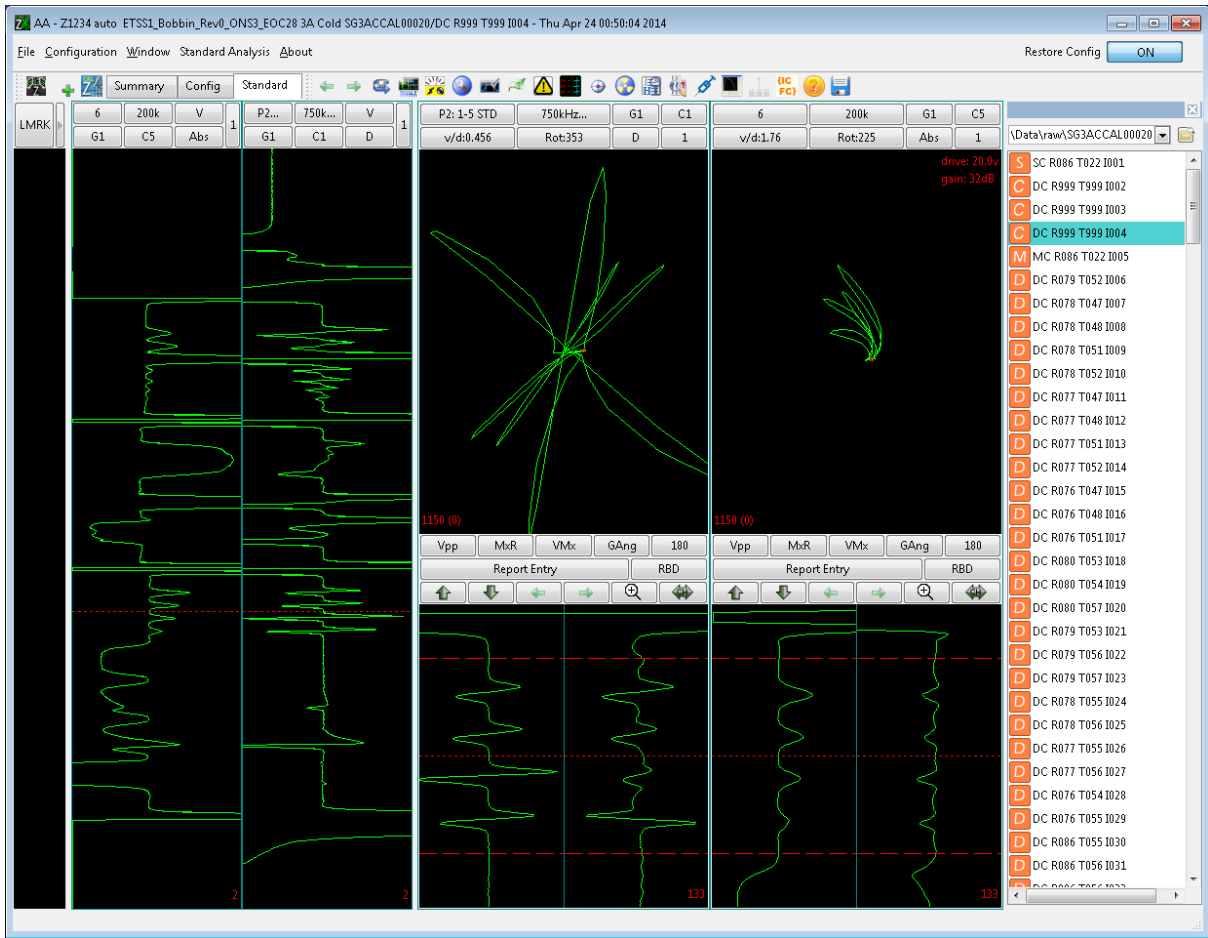

Bobbin Analysis with EddyNet Software

We set the standard for efficient and accurate inspection with our tubing bobbin probes. We apply advanced materials, design and production so that you acquire high signal to noise eddy current data that's consistent through the duration of the inspection, as well as for the life of the probe.

Our tubing bobbin probes are built for flexibility, allowing for optimal navigation through tubing u-bends, while maintaining high data quality. With our expertise in developing inspection solutions, and our extensive field experience, you can rely on our tubing bobbin probes to satisfy your tube inspection needs.

BS Barnacle Scraper Bobbin Probe

Barnacle Scraper (BS) Bobbin Probes are used in applications which require rugged probes for testing straight sections of tubing. Zetec’s BS probes are the industry standard for value, performance, and quality of eddy current signal.



Standard Features

- Designed for inspection of non-ferrous, straight tubes
- Stainless steel front scraper minimizes probe damage from sharp tube deposits/crustacean shells
- Wear resistant coil coating
- Tapered back bearing alleviates catching on far tube end during retraction
- Internal stainless steel retention cable

Standard Options

Probe Diameters	Push Poly Length	Push Poly Type	Frequency Range	Connectors
0.380" (9.65mm) to 1.250" (31.75mm) in 0.010" increments	50' (15.2m) 83' (25.3m) 100' (30.5m)	5/16T (Thin wall) 3/8T (Thin wall) 3/8H (Heavy wall)	Multiple ranges available	4 pin, 36 pin or 2 BNC
Custom options are available for all items				

CBS Chamfered Barnacle Scraper Bobbin Probe

The chamfered nose cone version of the BS probe is the most popular probe for basic tube inspections. The chamfered nose allows for the probe to pass through segments of tubing that have restrictions with less push effort.



Standard Features

- Designed for inspection of non-ferrous, straight tubes
- Chamfered probe tip for ease of tube entry
- Stainless steel front scraper minimizes probe damage from sharp tube deposits/crustacean shells
- Wear resistant coil coating
- Tapered back bearing alleviates catching on far tube end during retraction
- Internal stainless steel retention cable

Standard Options

Probe Diameters	Push Poly Length	Push Poly Type	Frequency Range	Connectors
0.380" (9.65mm) to 1.250" (31.75mm) in 0.010" increments	50' (15.2m) 83' (25.3m) 100' (30.5m)	5/16T (Thin wall) 3/8T (Thin wall) 3/8H (Heavy wall)	Multiple ranges available	4 pin, 36 pin or 2 BNC
Custom options are available for all items				

MCBS Mag Biased CBS Bobbin Probe

The magnetically biased chamfered barnacle scraper bobbin probe includes post magnets on both sides of the coils providing better signals when inspecting non-ferromagnetic tubes that may have some magnetic permeability anomalies.



Standard Features

- Designed for inspection of non-ferrous with some magnetic permeability, straight tubes
- Chamfered probe tip for ease of tube entry
- Stainless steel front scraper minimizes probe damage from sharp tube deposits/crustacean shells
- Wear resistant coil coating
- Tapered back bearing alleviates catching on far tube end during retraction
- Internal stainless steel retention cable

Standard Options

Probe Diameters	Push Poly Length	Push Poly Type	Frequency Range	Connectors
0.380" (9.65mm) to 1.250" (31.75mm) in 0.010" increments	50' (15.2m) 83' (25.3m) 100' (30.5m)	5/16T (Thin wall) 3/8T (Thin wall) 3/8H (Heavy wall)	Multiple ranges available	4 pin, 36 pin or 2 BNC
Custom options are available for all items				

NEW! HS Flexible High Stability Bobbin Probe

Standard Features

- Designed for inspection of non-ferrous tubing
- Flexible probe head for both straight and U-bend tube inspection
- Probe head minimum U-bend radius: ~5" (127mm) depending on test conditions.
- **Low drift coax** for more stable data null point
- **Spring expanded centering feet** (petals) for improved probe centering
- **Longer wear centering foot** (petal)
- **Bead covered** stainless steel flex member
- Programmed identification, authentication device (Nuclear steam generator probes)

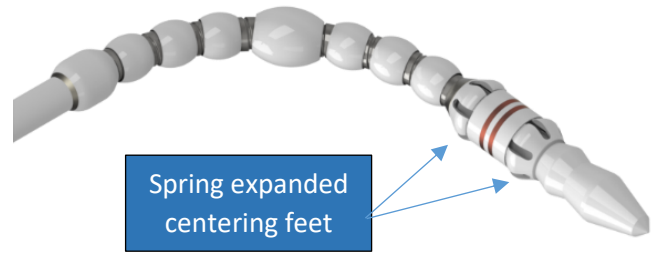

NEW! M/HS Flexible Mag Biased High Stability Bobbin Probe

Standard Features

- Same basic design as HS bobbin probe
- With permanent magnets for suppression of tubing magnetic permeability variations

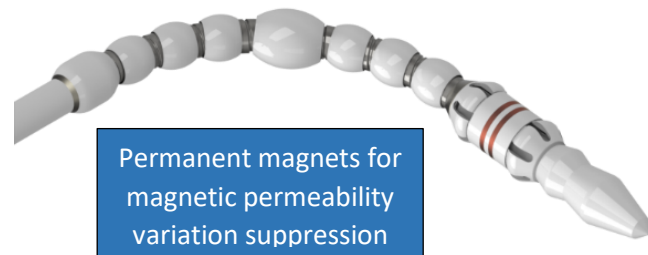

Standard Options

Probe Diameters	Push Poly Length	Push Poly Type	Frequency Range	Connectors
0.450" (11.43mm) to 0.900" (22.8mm) in 0.010" increments	50' (15.2m) 83' (25.3m) 100' (30.5m) 110' (33.5m)	5/16T (Thin wall) 5/16H (Heavy wall) 3/8T (Thin wall) 3/8H (Heavy wall)	Multiple ranges available	4 pin, 36 pin or 2 BNC
Custom options are available for all items				

NEW! HS/XP Flexible High Stability Bobbin Probe Equivalent to X-Probe Bobbins

Standard Features

- Same basic design as HS bobbin probe
- X-Probe equivalent coaxial cable inside push tube.
- X-Probe matching coil windings
- Low drift coax for more stable data null point
- Spring expanded centering feet (petals) for improved probe centering and longer wear

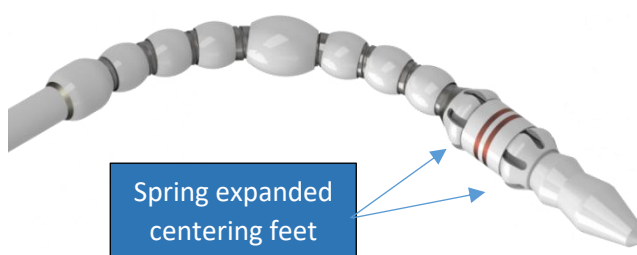

NEW! M/HS/XP Flexible Mag Biased High Stability Bobbin Probe Equivalent to X-Probe Bobbins

Standard Features

- Same basic design as HS bobbin probe
- With additional X-Probe matching permanent magnets for suppression of tubing magnetic permeability variations

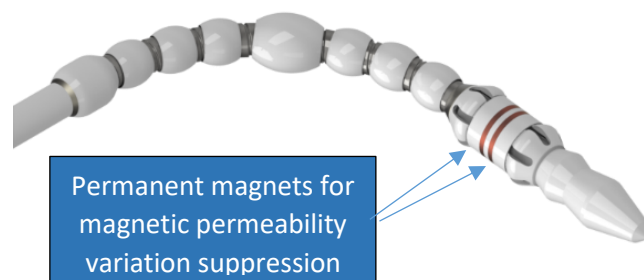

Standard Options

Probe Diameters	Push Poly Length	Push Poly Type	Frequency Range	Connectors
0.450" (11.43mm) to 0.900" (22.8mm) in 0.010" increments	50' (15.2m) 83' (25.3m) 100' (30.5m) 110' (33.5m)	5/16T (Thin wall) 5/16H (Heavy wall) 3/8T (Thin wall) 3/8H (Heavy wall)	Multiple ranges available	4 pin, 36 pin or 2 BNC
Custom options are available for all items				

NEW! MHS/LL Flexible Bobbin Probe



Standard Features

- Designed for inspection of non-ferrous tubing
- Flexible probe head for both straight and U-bend tube inspection
- Probe head minimum U-bend radius: ~5" (127mm) depending on test conditions.
- **Co-extruded push tube (poly)**
- **Bead covered** stainless steel flex member
- LLMC probe equivalent coil windings
- Low drift coax for more stable data null point
- **Spring expanded centering feet (petals)** for improved probe centering
- **Longer wear centering foot (petal)**
- Permanent magnets for suppression of magnetic permeability variations

Standard Options

Probe Diameters	Push Poly Length	Push Poly Type	Frequency Range	Connectors
0.560"	110' (33.52m)	3/8" Co-extruded	Equivalent to Long Life probes	36 pin
0.600"	110' (33.52m)			
0.610"	75' (22.86m)			
	110' (33.52m)			
0.720"	120' (36.57m)			
	110' (33.52m)			

Zetec ULC probes have been the industry standard for over 25 years

ULC Flexible Bobbin Probe

Standard Features

- Designed for inspection of non-ferrous tubing
- Flexible probe head for both straight and U-bend tube inspection
- Probe head minimum U-bend radius: ~5" (127mm) depending on test conditions.
- Programmed identification, authentication device (Nuclear steam generator probes)



M/ULC Flexible Mag Biased Bobbin Probe

Standard Features

- Same basic design as ULC bobbin probe
- With permanent magnets for suppression of tubing magnetic permeability variations

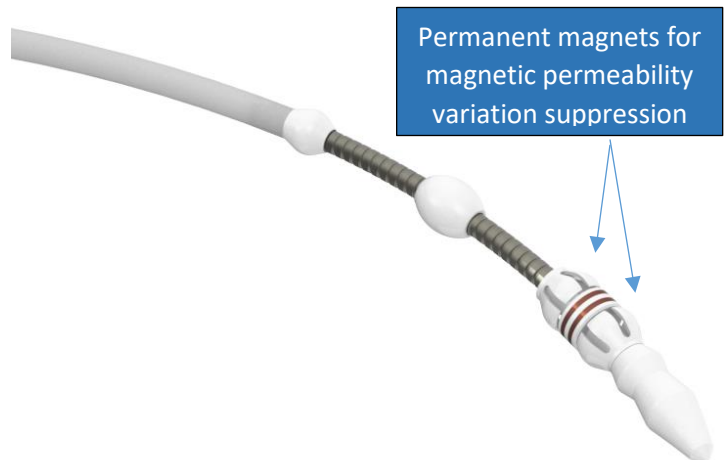

Standard Options

Probe Diameters	Push Poly Length	Push Poly Type	Frequency Range	Connectors
0.450" (11.43mm) to 0.900" (22.8mm) in 0.010" increments	50' (15.2m) 83' (25.3m) 100' (30.5m) 110' (33.5m)	5/16T (Thin wall) 5/16H (Heavy wall) 3/8T (Thin wall) 3/8H (Heavy wall)	Multiple ranges available	4 pin, 36 pin or 2 BNC
Custom options are available for all items				

ULC/XP Flexible Bobbin Probe Equivalent to the X-probe Bobbin

Standard Features

- Same basic design as ULC bobbin probe
- X-Probe equivalent coaxial cable inside push tube.
- X-Probe equivalent coil windings

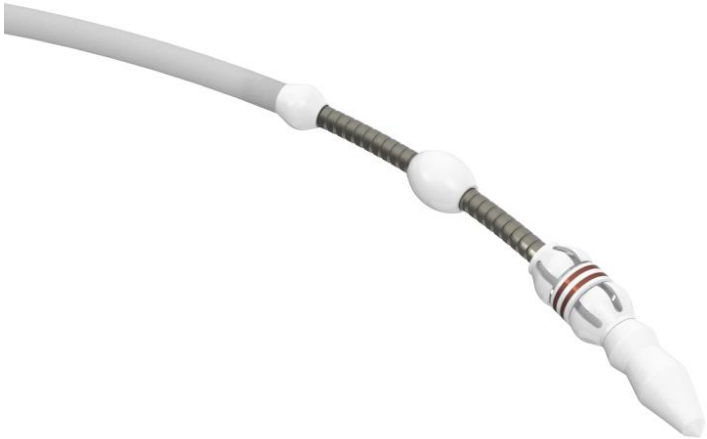

M/ULC/XP Flexible Mag Biased Bobbin Probe Equivalent to the X-Probe Bobbin

Standard Features

- Same basic design as ULC bobbin probe
- With additional X-Probe equivalent permanent magnets for suppression of tubing magnetic permeability variations

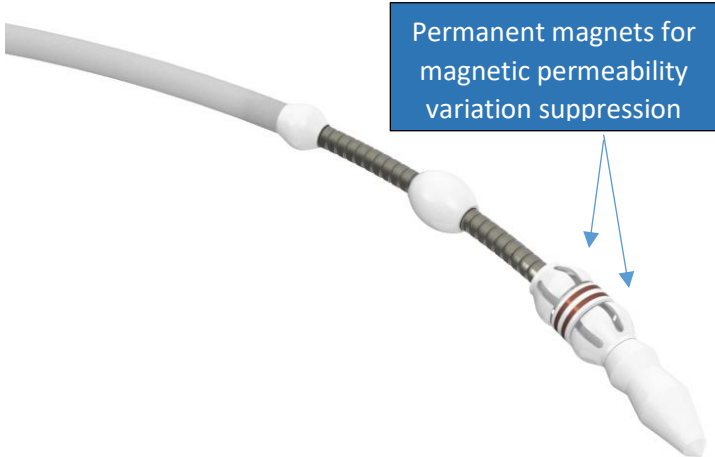

Standard Options

Probe Diameters	Push Poly Length	Push Poly Type	Frequency Range	Connectors
0.450" (11.43mm) to 0.900" (22.8mm) in 0.010" increments	50' (15.2m) 83' (25.3m) 100' (30.5m) 110' (33.5m)	5/16T (Thin wall) 5/16H (Heavy wall) 3/8T (Thin wall) 3/8H (Heavy wall)	Multiple ranges available	36 pin
Custom options are available for all items				

ULC/C* Bobbin Probe for Tight Bends

Standard Features

- Same basic design as ULC bobbin probe
- With extra flexible beaded section behind the probe head.

* Specify length of beaded section.

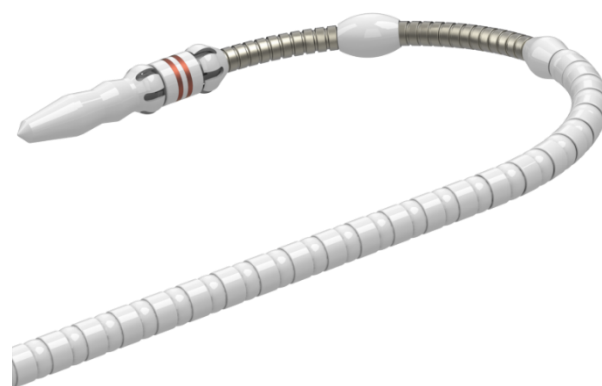

M/ULC/C* Mag Biased Bobbin Probe for Tight Bends

Standard Features

- Same basic design as ULC bobbin probe
- With extra flexible beaded section behind the probe head.

* Specify length of beaded section.

- With permanent magnets for suppression of tubing magnetic permeability variations

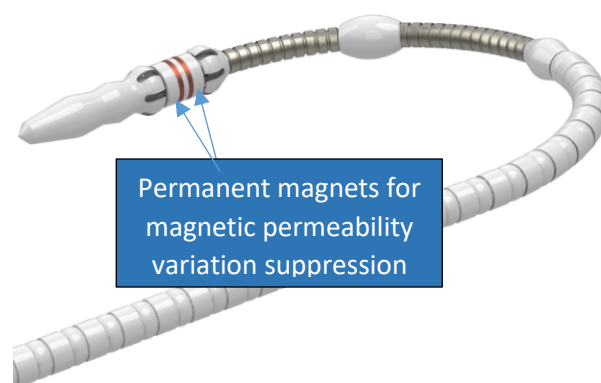

Standard Options

Probe Diameters	Push Poly Length (Includes beaded section)	* Beaded section length	Push Poly Type	Frequency Range	Connectors
0.450" (11.43mm) to 0.900" (22.8mm) in 0.010" increments	50' (15.2m) 83' (25.3m) 100' (30.5m) 110' (33.5m)	2 feet (610mm) 4 feet (1.22m)	5/16T (Thin wall) 5/16H (Heavy wall) 3/8T (Thin wall) 3/8H (Heavy wall)	Multiple ranges available	4 pin, 36 pin or 2 BNC
Custom options are available for all items					

URF Flexible Bobbin Probe for Small Diameter Tubing

Standard Features

- Designed for inspection of non-ferrous tubing
- Flexible probe head for both straight and U-bend tube inspection
- Probe head minimum U-bend radius: ~5" (127mm) depending on test conditions.
- Programmed identification, authentication device (Nuclear steam generator probes)

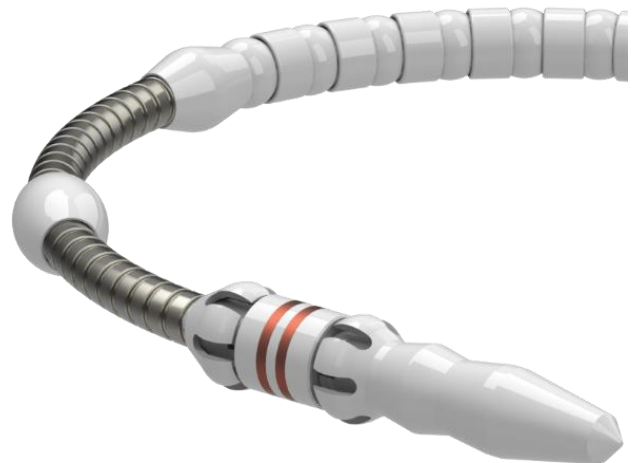

M/URF Flexible Bobbin Probe for Small Diameter Tubing

Standard Features

- Same basic design as URF bobbin probe
- With permanent magnets for suppression of tubing magnetic permeability variations

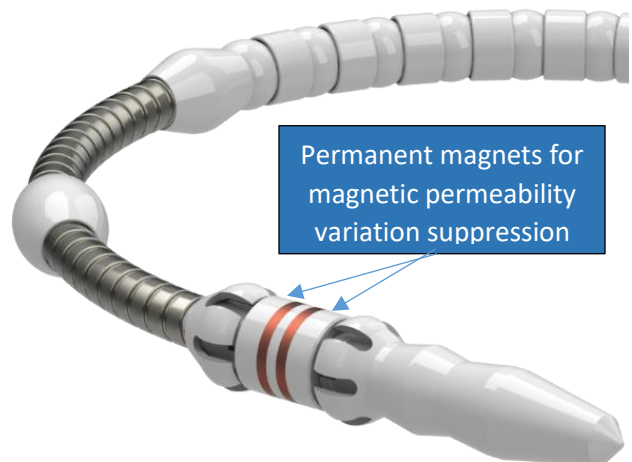

URF and M/URF Standard Options

Probe Diameters	Push Poly Length	Push Poly Type	Frequency Range	Connectors
0.380" (9.6mm) to 0.470" (11.93mm) in 0.010" increments	50' (15.2m) 83' (25.3m) 100' (30.5m)	5/16T (Thin wall) 5/16H (Heavy wall)	Multiple ranges available	4 pin or 36 pin
Custom options are available for all items				

URF/C* Flexible Bobbin Probe for Small Diameter Tubing and Tight Bends

Standard Features

- Same basic design as URF bobbin probe
- With extra flexible beaded section behind the probe head.
- * Specify length of beaded section (2 or 4 feet).

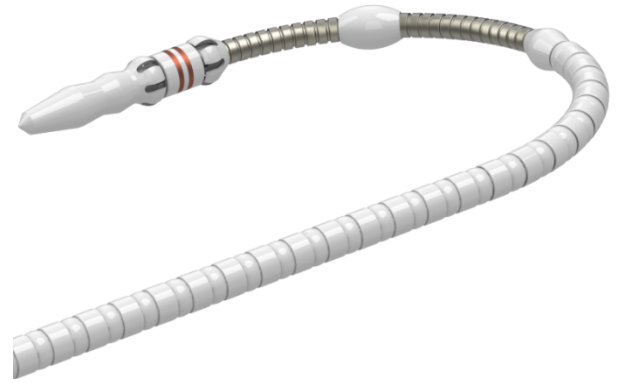

M/URF/C* Flexible Mag Biased Bobbin Probe for Small Diameter Tubing and Tight Bends

Standard Features

- Same basic design as URF bobbin probe
- With extra flexible beaded section behind the probe head.
- * Specify length of beaded section (2 or 4 feet).
- With permanent magnets for suppression of tubing magnetic permeability variations

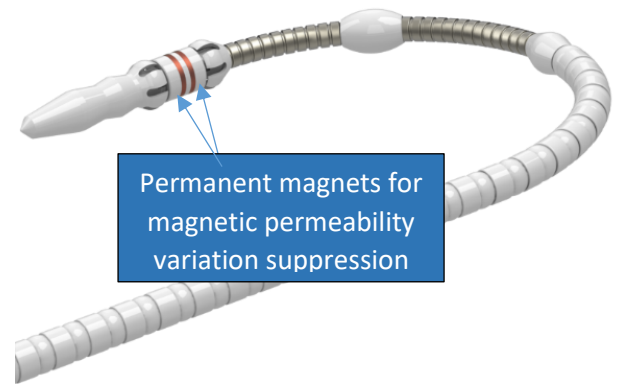

URF/C and M/URF/C Standard Options

Probe Diameters	Push Poly Length	Push Poly Type	Frequency Range	Connectors
0.340" (8.64mm) to 0.470" (11.93mm) in 0.010" increments	50' (15.2m) 83' (25.3m) 100' (30.5m)	5/16T (Thin wall)	Multiple ranges available	4 pin or 36 pin
Custom options are available for all items				

BJF Flexible Bobbin Probe for Small Diameter Tubing, Tight Bends and No Centering Feet

Standard Features

- Designed for inspection of non-ferrous tubing
- Extremely flexible probe head for difficult to inspect, small radius U-bend tubes
- Probe head minimum U-bend radius: ~2.5" (63.5mm) depending on test conditions.
- Probe diameters ordered are generally 0.080" to 0.100" under the tube inside diameter. Optimum probe diameter will depend on the tube nominal inside diameter, the amount of tube ovality and tube surface conditions
- Programmed identification, authentication device (Nuclear steam generator probes with 36 pin connector only)

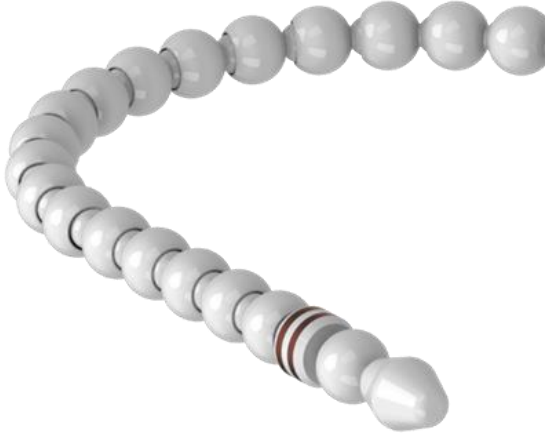

M/BJF Flexible Mag Biased Bobbin Probe for Small Diameter Tubing, Tight Bends and No Centering Feet

Standard Features

- Same basic design as BJB bobbin probe
- With permanent magnets for suppression of tubing magnetic permeability variations

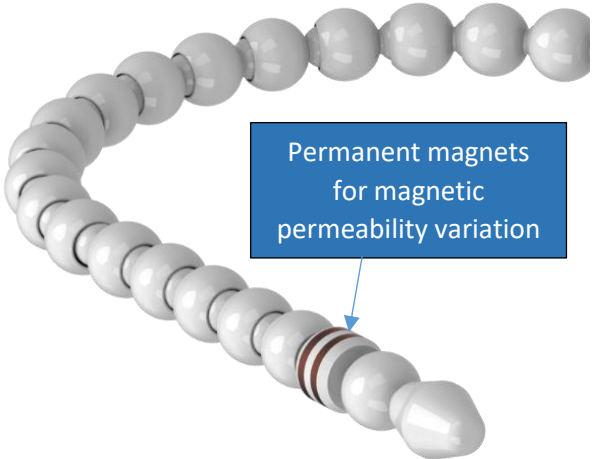

Standard Options

Probe Diameters	Push Poly Length	Push Poly Type	Frequency Range	Connectors
.300" (7.6mm) to .900" (22.86 mm) in 0.010" increments	50' (15.2m) 83' (25.3m) 100' (30.5m)	5/16T (Thin wall) 5/16H (Heavy wall) 3/8T (Thin wall) 3/8H (Heavy wall)	Multiple ranges available	4 pin or 36 pin 2 BNC
Custom options are available for all items				

F Flex Bobbin Probe



Standard Features

- Designed for inspection of non-ferrous tubing
- Flexible probe head for both straight and U-bend tube inspection
- Probe head minimum U-bend radius: ~5" (127mm) depending on test conditions
- Programmed identification, authentication device (Nuclear steam generator probes)

FM Flex Mag Biased Bobbin Probe



Standard Features

- Same basic design as F bobbin probe
- With permanent magnets for suppression of tubing magnetic permeability variations

Standard Options

Probe Diameters		Push Poly Length	Push Poly Type	Frequency Range	Connectors
F	FM	All Probes	All Probes	All Probes	All Probes
0.320" (8.13mm) to 0.930" (23.62mm) in 0.010" increments	0.340" (8.64mm) to 0.490" (12.45mm) in 0.010" increments	50' (15.2m) 83' (25.3m) 100' (30.48m)	5/16T (Thin wall) 5/16H (Heavy wall) 3/8T (Thin wall) 3/8H (Heavy wall)	Multiple ranges available	4 pin, 36 pin or 2 BNC
Custom options are available for all items					

LC4 Tube Roll Profiling Bobbin Probe

Standard Features

- Designed for inspection of straight non-ferrous tubing
- Longer probe head for higher stability in tube sheet roll transitions or near dents
- Additional centering feet (petals) for improved centering in tube sheet expansion
- Programmed identification, authentication device (Nuclear steam generator probes)

* Provide inside diameter of tube sheet expansion and nominal tube inside diameter when ordering. The standard centering foot outside diameter will be 0.045" (1.14mm) larger than the probe outside diameter



Standard Options

Probe Diameters	Push Poly Length	Push Poly Type	Centering Foot Diameter	Frequency Range	Connectors
0.460" (11.68mm) to 0.730" (18.54mm) in 0.010" increments	50' (15.2m) 83' (25.3m) 100' (30.5m) 110' (33.5m)	3/8T (Thin wall)	Probe outside diameter + 0.045" (1.14mm)	Multiple ranges available	4 pin, 36 pin or 2 BNC
Custom options are available for all items					

SAX EDF Steam Generator Bobbin Probe for French Market



Standard Features (See part numbers that end in “N”)

- Designed for inspection of non-ferrous EDF (Électricité de France) tubing
- Flexible probe head for both straight and U-bend tube inspection
- Bobbin Electromagnet for suppression of tubing magnetic permeability variations
- PMUC (Produits et Matériaux Utilisables en Centrale) compliant

SAX EDF Steam Generator Bobbin Probe with Rotating Feet for French Market

Standard Features (See part numbers that end in “O”)

- Same basic design as EDF S/G SAX bobbin probe
- With centering feet (Petals) that are free to rotate for longer, more even wear
- With beads that are free to rotate
- With longer flexible section behind coils

Standard Probes

Probe Part Number	Probe Diameter	Feet (Petal) type	Foot (Petal) Diameter	Push Poly Length	Push Poly Type	Connector
AASX001N	18.5mm	Stationary	19.7mm	33.5m	7mm	6 pin Jaeger
AASX001O	18.5mm	Rotating	19.7mm	33.5m	7mm	6 pin Jaeger
AASX002N	18.0mm	Stationary	19.7mm	33.5m	7mm	6 pin Jaeger
AASX002O	18.0mm	Rotating	19.7mm	33.5m	7mm	6 pin Jaeger
AASX003N	15.9mm	Stationary	16.9mm	33.5m	7mm	6 pin Jaeger
AASX003O	15.9mm	Rotating	16.9mm	33.5m	7mm	6 pin Jaeger
AASX004N	15.4mm	Stationary	16.9mm	33.5m	7mm	6 pin Jaeger
AASX004O	15.4mm	Rotating	16.9mm	33.5m	7mm	6 pin Jaeger

CTR1 Carter 1 Bobbin Probes



Standard Features

- Specialized differential bobbin with extremely strong, focused permanent magnet biasing. Capable of saturating or partially saturating mildly ferritic materials such as Monel, Sea-cure, 400 series stainless steel and 3RE60 depending on thickness and relative permeability.
- Designed to magnetically saturate Monel straight and larger radius steam generator U-bend tubing
- Ceramic foot petal wear inserts are for use in CANDU (CANada Deuterium Uranium) power plants
- Wear resistant ceramic foot (petal) inserts standard.
- Programmed identification, authentication device (36 pin probes)
- Titanium encased coils

Standard Options

Probe Versions	Body Type	Retrieval Wire	Foot Petal Wear Insert	Magnetic Field Orientation	Push Poly Length	Push Poly Type	Connector
CTR1	Standard	To head	None	Axial	Application specific	Application specific	4 pin, 36 pin
CTR1/CFI	Standard	To head	Ceramic	Axial	Application specific	Application specific	4 pin, 36 pin
CTR1/RWI	Standard	Full length	Ceramic	Axial	Application specific	Application specific	36 pin
CTR1/SBRWI	Short	Full length	Ceramic	Axial	Application specific	Application specific	36 pin
CTR1/CFI	Standard	To head	Ceramic	Axial	Application specific	Application specific	4 pin, 36 pin
CTR1/SBCFI	Short	To head	Ceramic	Axial	Application specific	Application specific	4 pin, 36 pin
CTR1/R	Standard	To head	Ceramic	Radial (For flaw detection under carbon steel supports)	Application specific	Application specific	4 pin

BSFI Bobbin Probes

Standard Features

- ULC type probe with ceramic foot inserts
- Designed to inspect non-ferrous CANDU (CANada Deuterium Uranium) power plant straight and U-bend tubing.
- Wear resistant ceramic foot (petal) inserts
- Flexible probe head for both straight and U-bend tube inspection
- Probe head minimum U-bend radius: ~5" (127mm) depending on test conditions
- Programmed identification, authentication device (36 pin probes)

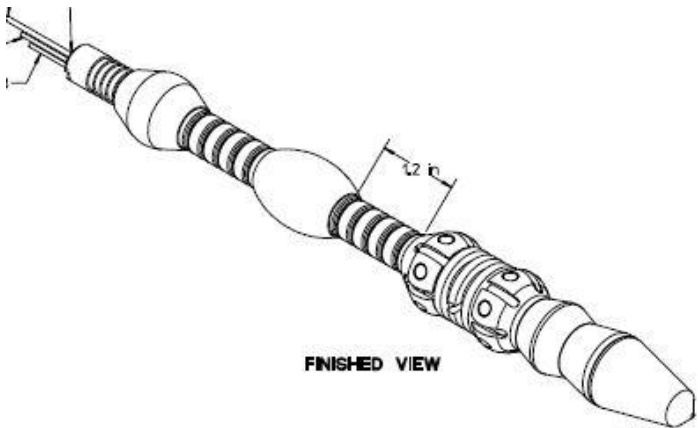

Standard Options

Probe Diameters	Push Poly Length	Push Poly Type	Frequency Range	Connectors
0.480" (12.0mm)	83' (25.3m) 100' (30.5m)	5/16T (Thin wall) 3/8T (Thin wall)	Multiple ranges available	4 pin 36 pin
Custom options are available for all items				

A/CFI Bobbin Probes



- Differential bobbin
- Designed to inspect straight and U-bend tubing.
- Ceramic foot petal wear inserts are for use in CANDU (CANada Deuterium Uranium) power plants.
- Programmed identification, authentication device
- Wear resistant ceramic foot (petal) inserts standard.
- Titanium encased coils

Standard Features

Probe Diameters	Push Poly Length	Push Poly Type	Frequency Range	Connectors
0.380" (9.65mm)	100' (30.5m)	5/16 HDPE-H		36 pin
Custom options are available for all items				

T/LC/NF Thimble Tube Bobbin Probe

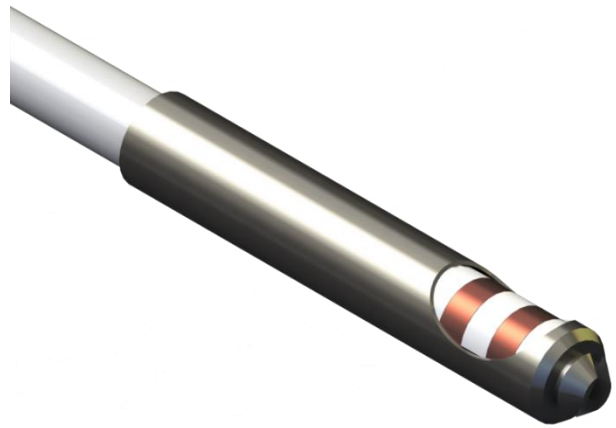

Standard Features

- Designed for inspection of nuclear reactor flux thimble tubes.
- Flat wound metal push tube (shaft) or Nylon push tube ($\geq .188''$ (4.77mm) probe diameter only)
- Fully encased differential bobbin coil pair

Standard Options

Probe Diameters	Push Poly Length	Push Tube Type	Frequency Range	Connectors
.175'' (4.44mm)	125' (38.1m)	.157'' (4mm) diameter flat-wound metal shaft only	Multiple ranges available	4 pin or 36 pin
.182'' (4.62mm)	125' (38.1m)	.157'' (4mm) diameter flat-wound metal shaft only	Multiple ranges available	4 pin or 36 pin
.188'' (4.77mm)	125' (38.1m)	.157'' (4mm) diameter flat-wound metal shaft or 3/16'' (4.76mm) Type H Nylon	Multiple ranges available	4 pin or 36 pin
Custom options are available for all items				

SUB/F Bobbin Probes for French Market

Standard Features

- Designed for inspection of non-ferrous tubing
- Flexible probe head for both straight and U-bend tube inspection
- PMUC (Produits et Matériaux Utilisables en Centrale) compliant



Standard Options

Probe Part Number	Probe Body Diameter	Frequency Range	Total Length	Push Tube Type	Centering Diameter	Connector
A138098B	9.8mm	50 kHz to 500 kHz	24.4m	¼T	11.5mm	6 pin Jaeger
SUBF-001	10.0mm	50 kHz to 500 kHz	24.4m	¼T	11.5mm	6 pin Jaeger

Array Probes



CXB4 and Combination X-Probe

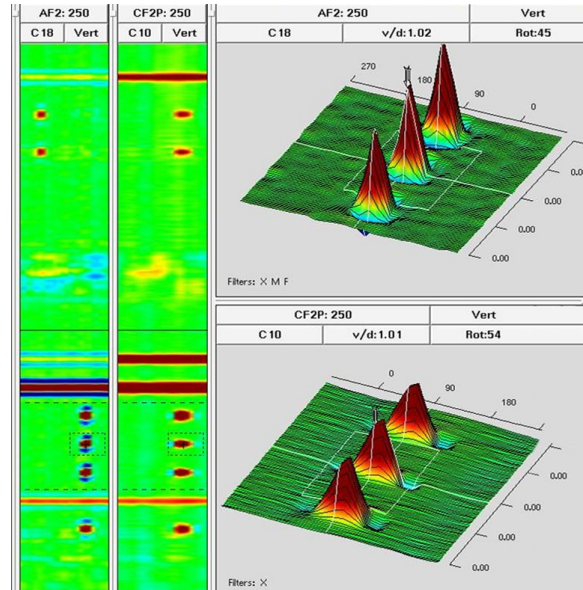

EddyNet Array Probe C-Scan Plot

Zetec is the leader in array coil technology. Our patent on reusing transmit and receive coils allows us to create a better coverage per coil density than anyone else in the industry. So when you use our probes for your inspections, you'll gather all of the necessary data in "one pass" through the tube, resulting in a cost savings on the procedure. Our selection of probes includes X-Probes, the standard array technology in the nuclear industry. Two technologies, array and bobbin, integrated into a single probe for shorter inspections, fewer probe changes, fewer trips to the platform, and reduced radiation exposure. CXB probes, designed to find circumferential cracks and other indications in non-nuclear heat exchangers.

Zetec X-Probes have been the industry standard for over 15 years

XP1 Flexible X-Probe for VVER Market

Standard Features

- Designed for inspection of non-ferrous VVER 1000 (0.512" ID) or 440 (0.519" ID) steam generator tubing
- Multi-coil array technology (No bobbin)
- Flexible probe head for both straight and bend inspection
- Probe head minimum U-bend radius: ~2.36" (60mm) depending on test conditions.
- Programmed identification, authentication device

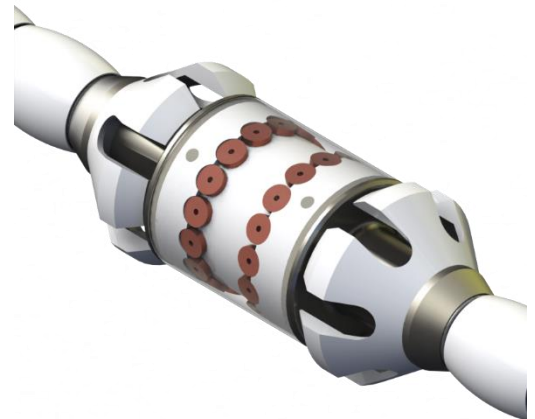

Standard Options

Probe Diameters	Push Poly Length	Push Poly Type	Application	Connectors
0.430" (10.92mm) or 0.440" (11.17mm)	52' (15.85m)	5/16 LM	Designed for inspection of 0.055" (1.4mm) or 0.059" (1.5mm) wall 321 stainless steel	36 pin
Custom options are available for all items				

XP2 Flexible X-Probe with Mag Biased Bobbin

Standard Features

- Designed for inspection of non-ferrous tubing
- Combination of array and bobbin technologies
- Flexible probe head for both straight and U-bend tube inspection
- Probe head minimum U-bend radius: ~10" (254mm) depending on test conditions
- Bobbin permanent magnets for suppression of tubing magnetic permeability variations
- Programmed identification, authentication device

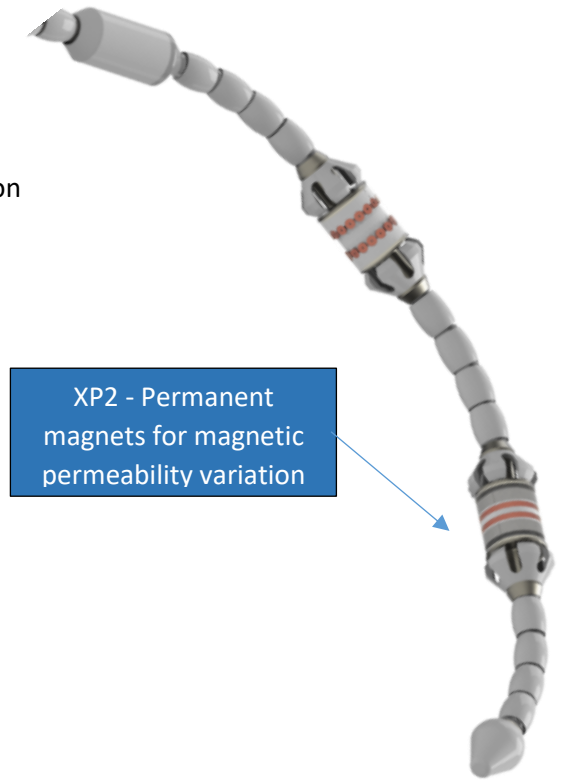

XP12 Flexible X-Probe with Bobbin

Standard Features

- Same basic design as the XP2
- Non-mag-biased bobbin (No permanent magnets)

Probe Diameters	Push Poly Length	Push Poly Type	Frequency Range	Connectors
0.330" (8.38mm) to 0.720" (18.29mm) in 0.010" increments	50' (15.2m) 83' (25.3m) 100' (30.5m) 110' (33.5m)	5/16T (Thin wall) 3/8T (Thin wall)	Multiple ranges available	36 pin
Custom options are available for all items				

XP2 Flexible X-Probe with SAX Bobbin (SAX SMX) for French Market

Standard Features

- Designed for inspection of non-ferrous EDF (Électricité de France) tubing
- Combination of array and bobbin technologies
- Flexible probe head for both straight and U-bend tubes
- Probe head minimum U-bend radius: ~10" (254mm) depending on test conditions.
- Bobbin Electromagnet for suppression of tubing magnetic permeability variations
- PMUC (Produits et Matériaux Utilisables en Centrale) compliant
- Programmed identification, authentication device

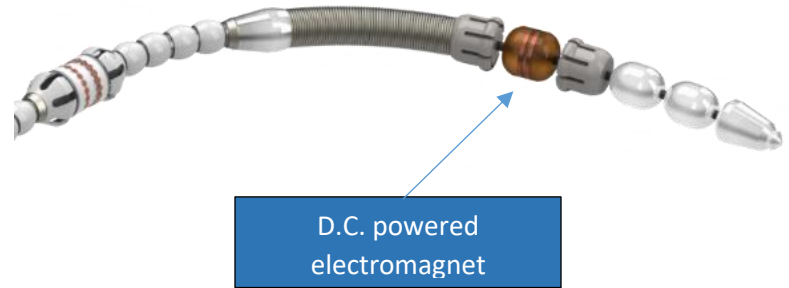

Probe Diameters	Push Poly Length	Push Poly Type	Frequency Range	Connectors
0.610" (15mm) and 0.720" (18mm)	105' (32m)	3/8T (Thin wall)		36 pin
Custom options are available for all items				

XP3 X-Probe for Tight Bends

Standard Features

- Array technology without bobbin coils
- Extra flexible probe head.
- Probe head minimum U-bend radius: ~2.5" (63.5mm)
- Programmed identification, authentication device
- PMUC (Produits et Matériaux Utilisables en Centrale) compliant version available

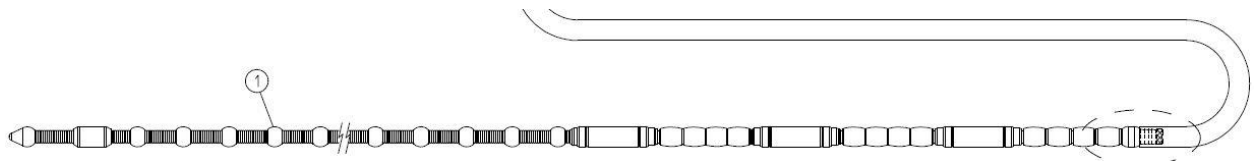

Standard Options

Probe Diameters		Push Poly Length	Push Poly Type	Frequency Range	Connectors
With Feet	Without Feet				
0.540" (13.72mm) to 0.710" (18.03mm) in 0.010" increments	0.360 (9.14mm) to 0.468" (11.89mm) in 0.010" increments	50' (15.2m) 83' (25.3m) 100' (30.5m) 110' (33.5m)	5/16T (Thin wall) 3/8T (Thin wall)	Multiple ranges available	36 pin
Custom options are available for all items					

XP4 Flexible Mag Biased X-Probe for CANDU Market

Standard Features

- Designed for inspection of **CANDU** heat exchanger tubing
- Multi-coil 3x12 array (Centered circumferential flaw sensors for magnet compatibility)
- Magnetically-biased for saturation of Monel 400
- Wear resistant ceramic foot petal Inserts
- Flexible probe head for both straight and U-bend tube inspection
- Probe head minimum U-bend radius: ~10" (254mm) depending on test conditions



Probe Diameters	Push Poly Length	Push Poly Type	Application	Connectors
0.330" (8.38mm) 0.350" (8.89mm)	90' (27.43m)	5/16 HDPE	Tuned for CANDU heat exchangers	36 pin
Custom options are available for all items				

XP6 Flexible X-Probe for CANDU Market

Standard Features

- Designed for inspection of **CANDU** heat exchanger tubing
- Short, titanium encased body
- Wear resistant ceramic foot petal inserts
- Multi-coil 3x12 array (Double the normal circumferential flaw sensors for increased resolution)
- Probe head minimum U-bend radius: 2.5" (63.5mm)



Standard Options

Probe Diameters	Push Poly Length	Push Poly Type	Application	Connectors
0.480" (12.19mm)	100' (30.48m)	3/8T	Tuned for CANDU heat exchangers	36 pin
Custom options are available for all items				

XP7 Flexible X-Probe with Snub Nose

Standard Features

- Designed for inspection of non-ferrous ROTSG and OTSG (Once through Steam Generator) tubing
- Combination of array and bobbin technologies
- Probe head designed for straight tube inspection
- Permanent magnets for suppression of tubing magnetic permeability variations
- Programmed identification, authentication device



Standard Options

Probe Diameters	Push Poly Length	Push Poly Type	Frequency Range	Connectors
0.510" (12.95mm)	83' (25.3m)	3/8T (Thin wall)	Tuned for OTSG tube inspection	36 pin
Custom options are available for all items				

XP10 Mag Biased X-Probe for Tight Bend CANDU



Standard Features

- Designed for inspection of CANDU heat exchanger tubing
- Titanium encased body
- Full length retrieval cord
- Wear resistant ceramic foot petal inserts
- Magnetically biased multi-coil 3x8 coil array
- Programmed identification, authentication device

Standard Options

Probe Diameters	Push Poly Length	Push Poly Type	Application	Connectors
0.350" (9.0mm)	90' (27.43m)	5/16 HDPE-H	CANDU heat exchangers	36 pin
Custom options are available for all items				

XP13 Flexible X-Probe for CANDU Tight Bends

Standard Features

- Designed for inspection of CANDU heat exchanger tubing
- Short, titanium encased body
- Wear resistant ceramic foot petal inserts
- Multi-coil 3x12 array
- Differential bobbin coils
- Probe head minimum U-bend radius: 2.5" (63.5mm)



Standard Options

Probe Diameters	Push Poly Length	Push Poly Type	Application	Connectors
0.380" (9.65mm) 0.480" (12.19mm)	100' (30.48m) or 83' (25.3m)	5/16T or 3/8T	CANDU heat exchangers	36 pin
Custom options are available for all items				

XP15 Flexible X-Probe for CANDU

Standard Features

- Designed for inspection of CANDU heat exchanger tubing
- Titanium encased body
- Wear resistant ceramic foot petal inserts
- Multi-coil 2x12 array

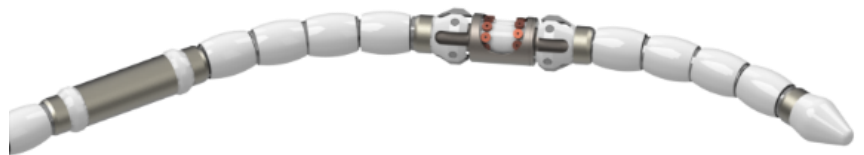

Standard Options

Probe Diameters	Push Poly Length	Push Poly Type	Application	Connectors
0.365" (9.27mm) or 0.380" (9.65mm)	100' (30.48m)	5/16T	CANDU heat exchangers	36 pin
Custom options are available for all items				

XP16 Flexible X-Probe with Mag Biased Array and Bobbin



Standard Features

- Designed for inspection of non-ferrous heat exchanger tubing

Standard Options

Probe Diameters	Push Poly Length	Push Poly Type	Frequency Range	Connectors
0.350" (8.89mm)	60' (18.29m)	5/16T	Multiple ranges available	36 pin
Custom options are available for all items				

CXB1 Array Probe



Standard Features

- Designed for inspection of non-ferrous tubing
- Combination of **circumferential** flaw sensitive array and bobbin technologies
- Flexible probe head for both straight and U-bend tube inspection
- Probe head minimum U-bend radius: ~10" (254mm) depending on test conditions.
- Programmed identification, authentication device
- Compatible Zetec Eddy Current Instruments: MIZ-80, MIZ-85, MIZ-200

Standard Options

Probe Diameters	Push Poly Length	Push Poly Type	Frequency Range	Connectors
0.330" (8.38mm) to 1.150" (29.21mm) in 0.010" increments	50' (15.2m) 83' (25.3m) 110' (33.5m)	5/16T (Thin wall) 3/8T (Thin wall)	Multiple ranges available	36 pin
Custom options are available for all items				

CXB2 Array Probe



Standard Features

- Designed for inspection of straight non-ferrous tubing
- Combination of **circumferential** flaw sensitive array and bobbin technologies
- Programmed identification, authentication device
- Compatible Zetec Eddy Current Instruments: MIZ-80, MIZ-85, MIZ-200

Standard Options

Probe Diameters	Push Poly Length	Push Poly Type	Frequency Range	Connectors
0.450" (11.43mm) to 1.150" (29.21mm) in 0.010" increments	50' (15.2m) 83' (25.3m) 110' (33.5m)	5/16T (Thin wall) 3/8T (Thin wall)	Multiple ranges available	36 pin
Custom options are available for all items				

CXB4 Array Probe



Standard Features

- Designed for inspection of straight non-ferrous tubing
- Combination of **circumferential/axial** flaw sensitive array and bobbin technologies
- Programmed identification, authentication device
- Compatible Zetec Eddy Current Instruments: MIZ-80, MIZ-85, MIZ-200

Standard Options

Probe Diameters	Push Poly Length	Push Poly Type	Frequency Range	Connectors
0.450" (11.43mm) to 0.900" (22.86mm) in 0.010" increments	50' (15.2m) 83' (25.3m) 110' (33.5m)	5/16T (Thin wall) 3/8T (Thin wall)	Multiple ranges available	36 pin
Custom options are available for all items				

MRPC Probes and Motor Units



Flex Head, Extension Shaft and DH3



9DNS Motor Unit with Protective Sleeve

Zetec is the leader in tubing rotating probes technology. We are backed by our nearly 50 years as the global leader in developing NDT solutions for the critical inspection needs of the world's major industries. Our expertise in developing technological solutions combined with our extensive field experience puts us in a unique position to understand your specific needs. Our rotating probes will provide you with the data necessary for you to make intelligent decisions.

We have created and developed thousands of probe designs successful at identifying and characterizing flaws across a range of applications. In addition to providing you with the rotating probe technology for your inspection solutions, we have track a record of providing support to our clients due to unforeseen issues that have arisen during the inspection process. As NDT industry leaders and inspection technology innovators, the experts at Zetec are your trusted advisers for your NDT solution needs.

DH1 One Coil Rotating Probe

Standard Features

- Designed for helical inspection of straight heat exchanger tubing
- Wear resistant coil holder
- Axial and circumferential crack sensitive +Point coil (~50 kHz to 400 kHz with ~240 kHz peak frequency)

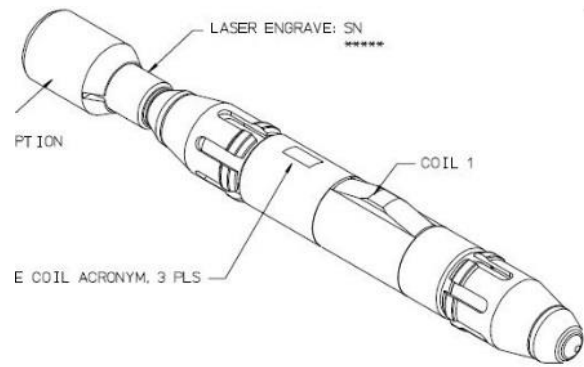

Standard Options

Probe Diameters	Coils	Connectors
0.380" (9.65mm) 0.480" (12.19mm)	Non-mag-biased PP11A +Point coil	5 pin or 7 pin (5/2) (≥0.480" diameter probes)
Custom options are available for all items		

DH2/PC Two Coil Rotating Probe

Standard Features

- Designed for helical inspection of straight heat exchanger tubing
- Wear resistant coil holder
- Axial and circumferential crack sensitive +Point coil (~50 kHz to 400 kHz with ~240 kHz peak frequency)
- Omni-directionally sensitive pancake coil (~50 kHz to 500 kHz with ~400 kHz peak frequency)
- Available with either standard coils or mag-biased coils



Standard Options

Probe Diameters	Coils	Connectors
0.500" (11.18mm) to 0.720" (18.29mm) in 0.010" increments	Non-mag-biased P115A pancake coil and PP11A +Point coil	7 pin (5/2) (≥0.480" diameter probes)
Custom options are available for all items		

DH3/PC Three Coil Rotating Probe

Standard Features

- Designed for helical inspection of straight heat exchanger tubing
- Wear resistant coil holder
- Axial and circumferential crack sensitive +Point coil (~50 kHz to 400 kHz with ~240 kHz peak frequency)
- Omni-directionally sensitive pancake coil (~50 kHz to 500 kHz with ~400 kHz peak frequency)
- Shielded, high resolution pancake coil (~200 kHz to 800 kHz with ~600 kHz peak frequency)
- Available with either standard coils or mag-biased coils



Standard Options

Probe Diameters	Coils	Connectors
0.520" (10.92mm) to 0.720" (11.17mm) in 0.010" increments	Non-mag-biased P115A pancake coil, SP080B pancake coil and PP11A +Point coil	7 pin (5/2)
Custom options are available for all items		

DI1 Dent Inspection Probe

Standard Features

- Designed for helical inspection of dented heat exchanger tubes
- Wear resistant coil holder
- Axial and circumferential crack sensitive +Point coil (~50 kHz to 400 kHz with ~240 kHz peak frequency)

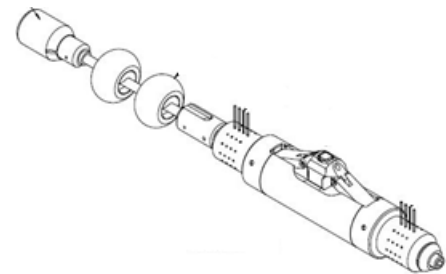

Standard Options

Probe Diameters	Coils	Connectors
0.500" (12.7mm) 0.580" (14.73mm) 0.720" (11.17mm)	PP11A +Point coil	7 pin (5/2)
Custom options are available for all items		

GPP Repair Sleeve Rotating Probe

Standard Features

- Designed for helical inspection of repair sleeves in straight heat exchanger tubing
- Wear resistant coil holder
- Axial and circumferential crack sensitive +Point coil
- Example coil: PP17A +Point coil for 100 kHz peak frequency, PP20A for 200 kHz peak frequency

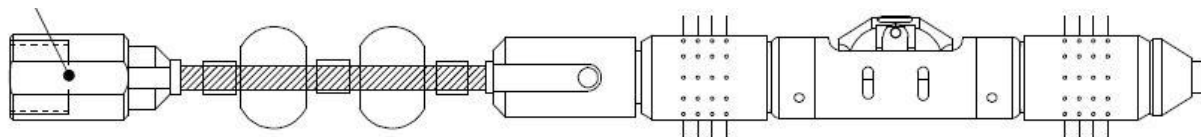

Standard Options

Probe Diameters	Coils	Connectors
0.290" (7mm) to 0.610" (15.49mm) in 0.010" increments	Various +Point coils	5 pin or 7 pin (5/2 type)
Custom options are available for all items		

BPP Tube Plug Inspection Probe

Standard Features

- Designed for helical inspection of heat exchanger tube plugs
- Wear resistant coil holder
- Axial and circumferential crack sensitive +Point coil

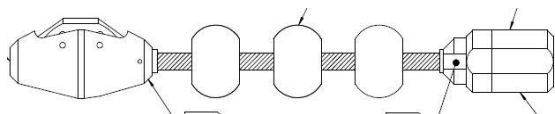

Standard Options

Probe Diameters	Coils	Connectors
0.410" (10.41mm) to 0.660" (16.76mm) in 0.010" increments	PP11A +Point coil	0.500"(12.7mm) diameter (7 pin (5/2 type)
Custom options are available for all items		

RPG (RG3-4) Rotating Array Probe

Standard Features

- Designed for detailed helical inspection straight heat exchanger tubing
- Wear resistant coil holder
- Very detailed resolution of axial and circumferential cracks



Standard Options

Probe Diameters	Coils	Connectors
0.440" (11mm) to 0.700" (18mm) in 0.010" increments	RG3-4 Type: 3 coil surface transmit and receive	3 pin or 7 pin (5/2)
Custom options are available for all items		

DH2/PSB D-Probe for Tube Profilometry Inspection

Standard Features

- Designed for helical inspection to provide inside diameter profiling (profilometry) and degradation detection of straight heat exchanger tubing
- 3D characterization of dents and bulges
- Wear resistant coil holder
- Dual centering feet for roll transition stability



Standard Options

Probe Diameters	Coils	Connectors
0.550" (14mm) 0.610" (15mm) 0.720" (18MM)	P115A + PP11A + SP080B or magnetically biased MP115A + MPP11A + MSP080B	7 pin (5/2)
Custom options are available for all items		

FH/R1 Small Radius U-Bend Rotating Probe



Standard Features

- Designed for helical inspection of **small radius U-Bend** heat exchanger tubing
- 18" long design
- Contour tracking, wear resistant coil holder
- Axial and circumferential crack sensitive +Point coil (~50 kHz to 400 kHz with ~240 kHz peak frequency)
- Extremely flexible shaft for inspection of ≥ 2.30 Radius U-bends
- Available with either standard coil or mag-biased coil

Standard Options

Probe Diameters	Probe Length	Coils	Connectors
0.480" (12.19mm) to 0.680" (17.27mm) in 0.010" increments	18" (457mm)	PP11A +Point coil	7 pin (5/2)
Custom options are available for all items			

FH Small Radius U-Bend Rotating Probe

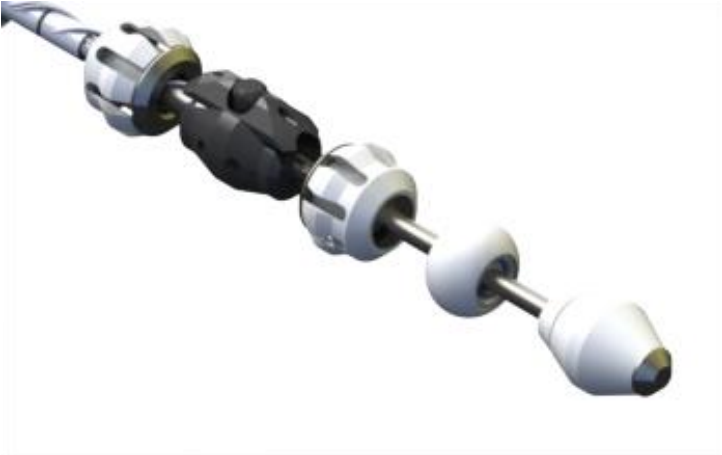

Standard Features

- Designed for helical inspection of small radius U-Bend heat exchanger tubing
- Contour tracking, wear resistant coil holder
- Axial and circumferential crack sensitive +Point coil (~50 kHz to 400 kHz with ~240 kHz peak frequency)
- Extremely flexible shaft for inspection of $\geq 2.30''$ Radius U-bends
- Available with either standard coil or mag-biased coil

Standard Options

Probe Diameters	Probe Lengths	Coils	Connector
0.480" (12.19mm) to 0.680" (17.27mm) in 0.010" increments	24" (609mm)	PP11A +Point coil	7 pin (5/2)
Custom options are available for all items			

STS Small Radius U-Bend Rotating Probe for French Market

Standard Features

- Designed for inspection of non-ferrous EDF (Électricité de France) tubing.
- Absolute pancake coil with internal reference coil.
- Up/Down indicator. External reference required.
- Locator bobbin coil. External reference required.
- Extremely flexible shaft for inspection of $\geq 2.5''$ Radius U-bends
- PMUC (Produits et Matériaux Utilisables en Centrale) compliant



Standard Options

Probe Part Number	Probe Body Diameter	Center Frequency	Probe Length (Connector end to coil center)	Centering Diameter	Connector
AATX017A	15.9mm	240kHz	664mm	19.8mm	Lemo 5 pin
AATX580B	13.34mm	280kHz	702.5mm	16.9mm	Lemo 5 pin
AATX680A	15.9mm	240kHz	664mm	19.9mm	Lemo 5 pin
10035666	15.9mm	240kHz	664mm	19.9mm	Lemo 5 pin

STT-STL Rotating Probe for French Market

Standard Features

- Designed for inspection of non-ferrous EDF (Électricité de France) tubing.
- STL element: Differential/absolute pancake coil pair at 45 degree angle.
- STT element: Anisotropic differential receive coils sharing common drive coil.
- Internal STT receive coil amplifier.
- PMUC (Produits et Matériaux Utilisables en Centrale) compliant



Photo côté capteurs STT



Standard Options

Probe Part Number	Probe Body Diameter	Frequency Range	Probe Length	Centering Diameter	Connector
B143185A	18.0mm	100 kHz to 600 kHz (240kHz center frequency)	180mm	20.4mm	Lemo 10 pin
B144152A	15.2mm	STL: 25kHz to 500 kHz STT: 140 kHz to 670 kHz	180mm	17.6/17.3mm	Lemo 12 pin
B144153A	15.2mm	STL: 25kHz to 500 kHz STT: 140 kHz to 670 kHz	180mm	17.6/17.3mm	Lemo 12 pin

STL Rotating Probe for French Market

Standard Features

- Designed for inspection of straight non-ferrous EDF (Électricité de France) tubing.
- Coil element: Differential/absolute pancake coil pair at 45 degree angle.
- PMUC (Produits et Matériaux Utilisables en Centrale) compliant



Standard Options

Probe Part Number	Probe Body Diameter	Frequency Range	Probe Length	Centering Diameter	Connector
10036340	18.0mm	100 kHz to 600 kHz	180mm	20.4mm	Lemo 10 pin
10036341	15.2mm	100kHz to 600 kHz	180mm	17.3/17.6mm	Lemo 12 pin
AASX020A	18.0mm	25kHz to 500 kHz	178mm	19.9/20.4	Lemo 5 pin
AASX021A	15.2mm	25kHz to 500 kHz	176mm	17.3/17.6mm	Lemo 5 pin

STE Rotating Probe for French Market

Standard Features

- Designed for inspection of straight non-ferrous EDF (Électricité de France) tubing.
- Coil element: Differential/absolute pancake coil pair at 45 degree angle.
- PMUC (Produits et Matériaux Utilisables en Centrale) compliant

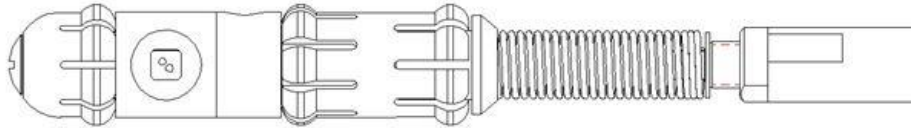

Standard Options

Probe Part Number	Probe Body Diameter	Probe Length	Centering Diameter	Connector
B150148A	14.8mm	151mm	17.3mm	Lemo 5 pin
B150185A	18.0mm	154.3mm	20.4mm	Lemo 5 pin
B151185A	18.0mm	154.3mm	20.4mm	Lemo 5 pin

Motor Units

9D and 9DNS Motor Unit (900 RPM)



Standard Features

- Designed to spin Zetec U-bend and straight tube rotating probe heads at 900 rpm
- Stainless steel motor housing. The 9DNS motor housing is covered with a Nylon sleeve
- Dual in-line D.C. micromotors with brushes
- Low noise precision gold contact slip-ring
- Low EMI cable
- 5 trigger signals per rotation
- Connector is compatible with probe head 5/2 connectors
- Torque: 120 oz./in.

Standard Options

Motor Diameters		Poly Length	Probe Head Connector	Instrument Connector
9D	9DNS	All Motors	All Motors	All Motors
0.560" (10.92mm) 0.610" (11.17mm) 0.720" (18.29mm)	0.610" (11.17mm)	50' (15.2m) 83' (25.3m)	7 pin (5/2)	36 pin
Custom options are available for all items				

12Q, 12QNS and 12Q/5PL Motor Unit (1200 RPM)



Standard Features

- Designed to spin Zetec straight tube rotating probe heads at 1200 rpm
- Stainless steel motor housing. The 12QNS motor housing is covered with a Nylon sleeve
- Four in-line D.C. micromotors
- Low noise precision gold contact slip-ring
- Low EMI cable
- 5 trigger signals per rotation
- Connector is compatible with probe head 5/2 connectors
- Torque: 120 oz./in.

Standard Options

Motor Diameters			Poly Length	Probe Head Connector			Instrument Connector
12Q	12QNS	12Q/5PL	All Motors	12Q	12QNS	12Q/5PL	All Motors
0.460" (11.68mm)) 0.500" (12.7mm)	0.560" (14.22mm)	0.460" (11.68mm)	50' (15.2m) 83' (25.3m)	7 pin (5/2)	7 pin (5/2)	5 Pin	36 pin
Custom options are available for all items							

3S Motor Unit (300 RPM)

Standard Features

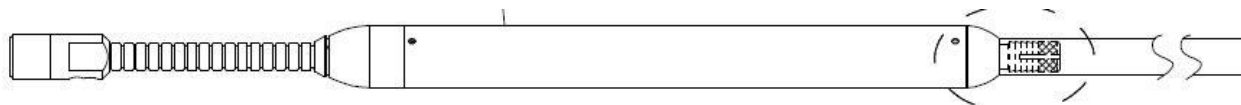

- Designed to spin Zetec U-bend and straight tube rotating probe heads at 300 rpm
- Stainless steel motor housing.
- Single D.C. micromotor with brushes
- Low noise precision gold contact slip-ring
- Low EMI cable
- 5 trigger signals per rotation
- Connector is compatible with probe head 5/2 connectors

Standard Options

Motor Diameters	Poly Length	Probe Head Connector	Instrument Connector
0.500" (12.70mm) 0.560" (14.22mm) 0.610" (11.17mm) 0.720" (18.29mm)	50' (15.2m) 83' (25.3m)	7 pin (5/2)	36 pin
Custom options are available for all items			

3S/F Motor Unit (300 RPM)

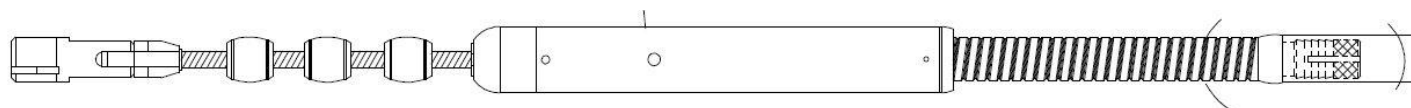

Standard Features

- Designed to spin Zetec straight tube rotating probe heads at 300 rpm
- 0.150" diameter flexible drive shaft and flex member between the motor and the Nylon tubing
(Allows improved rotation and translation when testing in confined spaces)
- Stainless steel motor housing. (Nylon covered motor housing versions available)
- Single D.C. micromotor with brushes
- Low noise precision gold contact slip-ring
- Low EMI cable
- 5 trigger signals per rotation
- Connector is compatible with probe head 3 pin connectors

Standard Options

Motor Diameters	Poly Length	Probe Head Connector	Instrument Connector
0.395" (10.03mm) 0.460" (11.68mm) 0.480" (12.19mm)	50' (15.2m) 83' (25.3m)	3 pin	36 pin
Custom options are available for all items			

HT/5PL and HT/3P Motor Unit (High Torque 300 RPM)

Standard Features

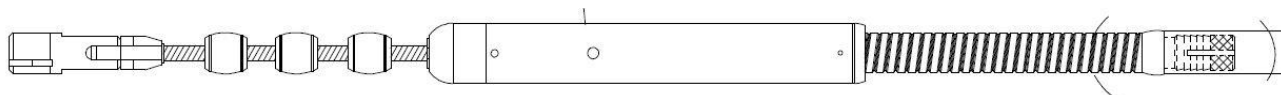

- Designed to spin Zetec straight tube rotating probe heads at 300 rpm
- 0.150" diameter flexible drive shaft and flex member between the motor and the Nylon tubing
- Stainless steel motor housing.
- Dual in-line D.C. micromotors with brushes (More torque than the single D.C. motor 3S/F motor unit)
- Low noise precision gold contact slip-ring
- Low EMI cable
- 5 trigger signals per rotation
- Connector is compatible with probe head 3 pin connectors

Standard Options

Motor Diameters		Poly Length	Probe Head Connector		Instrument Connector
HT/5PL	HT/3P	All Motors	HT/5PL	HT/3P	All Motors
0.460" (11.68 mm)	0.395" (10.03 mm)	50' (15.2m) 83' (25.3m)	5 pin	3 pin	36 pin
Custom options are available for all items					

HT Motor Unit (High Torque 300 RPM)

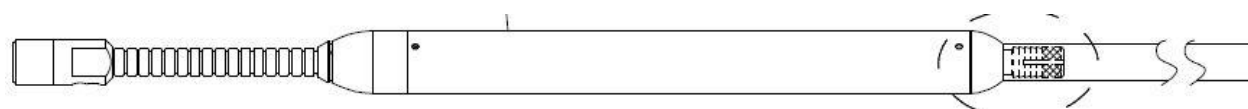

Standard Features

- Designed to spin Zetec straight tube and U-bend rotating probe heads at 300 rpm
- Stainless steel motor housing.
- Dual in-line D.C. micromotors with brushes

≥0.560" diameter: More torque than the single D.C. motor 3S motor unit

<0.560" diameter: More torque than the single D.C. motor 3S/F motor unit

- Low noise precision gold contact slip-ring
- Low EMI cable
- 5 trigger signals per rotation
- Connector is compatible with probe head 5/2 connectors

Standard Options

Motor Diameters	Poly Length	Probe Head Connector	Instrument Connector
0.460" (11.68mm) 0.500" (12.70mm) 0.610" (11.17mm) 0.720" (18.29mm)	50' (15.2m) 83' (25.3m)	7 pin (5/2)	36 pin
Custom options are available for all items			

24S Motor Unit (2400 RPM) Discontinued per Bulletin 05-1437, Contact Zetec for Other Options

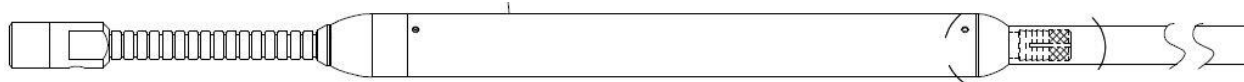

Standard Features

- Designed to spin Zetec U-bend and straight tube rotating probe heads at 2400 rpm
- Stainless steel motor housing.
- Single, high torque brushless motor
- Low noise precision gold contact slip-ring
- Low EMI cable
- 5 trigger signals per rotation
- Connector is compatible with probe head 5/2 connectors

Standard Options

Motor Diameters	Poly Length	Probe Head Connector	Instrument Connector
0.480" (12.19mm) 0.580" (14.73)mm 0.610" (15.49mm)	50' (15.2m) 83' (25.3m)	7 pin (5/2)	36 pin
Custom options are available for all items			

TTS Rotating Probe Top of Tubesheet Extension Shafts

Standard Features

- Extends flexible style rotating probe heads into large bends where motor units cannot travel



Standard Options

Probe Diameters	Extension Length	Connectors
0.520in (13mm)	18in (0.46m)	5/2 to 5/2 Pin Insert
0.560in (14mm)	24in (0.61m)	
0.580in (15mm)	36in (0.91m)	
0.680in (17mm)	48in (1.22m)	
	60in (1.52m)	
	72in (1.83m)	
	90in (2.29m)	
Custom options are available for all items		

TEO Bobbin Probe for Mildly Ferritic Tubes

Standard Features

- Titanium encased probe head for straight tube inspection
- Designed to partially saturate and suppress magnetic permeability noise in mildly ferritic materials such as Monel, 3RE60, SEA-CURE, and 400 series stainless steel



Standard Options

Probe Diameters	Push Poly Length	Push Poly Type	Frequency Range	Connectors
.400" (10.16mm) to 1.070" (27.18mm) in 0.010" increments	65' (25.3m)	5/16T (Thin wall) 3/8T (Thin wall)	Multiple ranges available	4 pin
Custom options are available for all items				

Encircling Probes

ENC/2 and ENC/3 Bobbin Encircling Probe

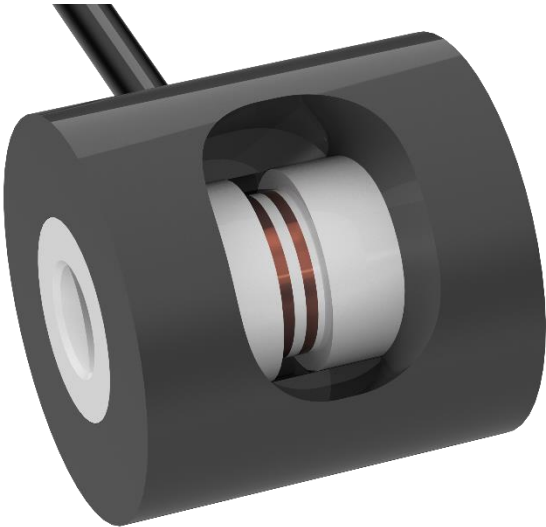

Standard Features

- Dual bobbin encircling coils.
- Designed for inspection of straight non-ferrous tubing
- 2" (ENC/2) or 3" (ENC/3) diameter outer housing

Standard Options

Probe Inside Diameters		Cable Length	Connector
ENC/2	ENC/3	6' (1.83m)	4 pin
0.030" (0.762mm) to 1.000" (25.4mm) in 0.010" increments	1.010" (25.654mm) to 2.000" (50.8mm) in 0.010" increments		
Custom options are available for all items			

ENC/RCCA/DUAL Array and Bobbin Encircling Probe



Standard Features

- Array of non-surface riding absolute pancake coils
- Dual bobbin encircling coils
- Radiation resistant cable
- Designed for inspection of nuclear power plant rod cluster control assembly (RCCA) tubes.
- Multiple probes typically used simultaneously
- With or without centering devices

Standard Options

Probe Diameters	Cable Length	Connector
0.400" (10.0mm)	100ft (30.5m)	36 pin
Custom options are available for all items		

Handheld Eddy Current Probes

DTP Detachable Tip Pencil Probe with Tapered Tip

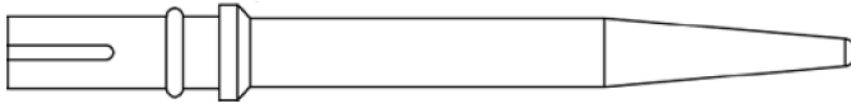

Standard Features

- 3.4 in. long tip
- 50 - 500kHz frequency range

DTPS Detachable Tip Pencil Probe, Shielded

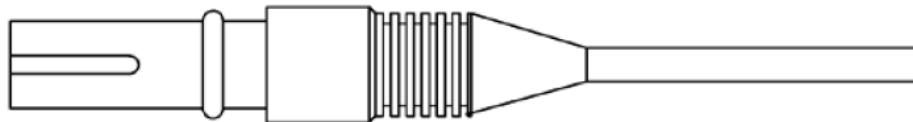

Standard Features

- 1.25 in. long tip
- Frequency range options: 50kHz - 500kHz, 500kHz - 1MHz

9DTS 90 Degree Detachable Tip Pencil Probes, Shielded



Standard Features

- 90-degree tip
- Frequency range options: 50kHz - 500kHz, 500kHz - 1MHz

DTSPS Detachable Tip Spot Probes, Spring Loaded

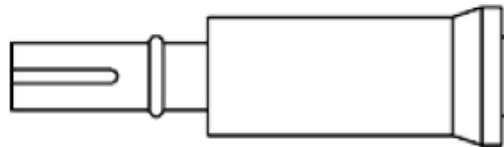

Standard Features

- Spot probe
- 0.375" diameter spring loaded coil surface
- 0.870" diameter body
- 50kHz - 500kHz frequency range

WSP/+P Detachable Tip Weld Scan +Point Probe



Standard Features

- Radius probe tip for inspection of raised weld beads
- Operating in differential mode
- 30kHz – 300kHz frequency range

DTPH Detachable Tip Probe Handles



Standard Features

- 6-foot cable
- Compatible with all detachable tip probes
- 4-pin Fischer connector
- Probe handle length options: 2 in., 3 in.

Eddy Current Surface Array Probes

Eddy current surface array probes allow for fast inspection of surfaces with varying materials and geometries utilizing the eddy current technique. Surface preparation is not necessary as compared to penetrant inspection methods. Additionally, there are no chemical usage or environmental concerns as compared to Magnetic Particle or penetrant inspection methods.

XPSFP Surface Array Flex Probe

The Surface Array Flex Probe allows you to reduce inspection time and improve flaw detection, all the while providing you with a full record of inspection. It offers simple “one-pass” inspections of the weld bead, transition zone, and heat-affected zone. The unique flexible surface design and proprietary X-Probe coil technology allows it to conform to the weld surface where it can detect pitting and surface cracks in any orientation. The probe transmits data directly to the MIZ-200 acquisition software, where it is analyzed and stored.



Standard Features

- Maximum weld bead height: 0.197 in. (5 mm)
- Minimum detectable crack (L x W x D): 0.020 in., 0.004 in., 0.020 in. (0.5mm, 0.1mm, 0.5mm)
- Maximum penetration depth: 0.039 in. (1mm) (Stainless Steel)
- Includes custom carrying case
- Optional encoder for accurate sizing and positioning of defects
- Use with MIZ-200 Array Instrument & Velocity Acquisition and Analysis Software

Standard Options

Surface Coverage	Cable Length	Coil Diameter	Center Frequency	Connectors
2.047 in. (52mm)	13' (4m) 33' (10m)	0.079 in. (2mm)	500kHz	MIZ-200 Array Connector
Custom options are available for all items				

Ferrous Tubing Probes RFT, NFT, MFL, IRIS

✓	The test method has proven results for the specific application
Limited	The test results obtained from the test method can be interpreted reasonably.
	Test method is either not suitable for the sought application or non-reliable in terms of repeatability

Tube material	Tube type	ECT	ECA	IRIS	RFT	NFT	MFL
Non-Ferromagnetic	Tube	✓	✓	✓			
	Integral finned tube	✓	✓	✓			
Low Ferromagnetic	Tube	Limited	Limited	✓	✓	✓	✓
	Integral finned tube	Limited	Limited	✓	✓	✓	✓
Ferromagnetic	Tube			✓	✓	✓	✓
	Integral finned tube			Limited	✓	✓	✓
	Aluminum finned tube			✓		✓	✓

Selection of NDT test method based on detection sensitivity

Discontinuity Sought	Sensitivity Criteria	ECT	ECA	IRIS	RFT	NFT	MFL
ID Pitting	Probability of Detection						
	Sizing capability						
OD Pitting	Probability of Detection						
	Sizing capability						
Axial cracking	Probability of Detection						
	Sizing capability						
Circumferential crack	Probability of Detection						
	Sizing capability						
ID Corrosion	Probability of Detection						
	Sizing capability						
OD Corrosion	Probability of Detection						
	Sizing capability						
At tubesheet	Probability of Detection						
	Sizing capability						

Remote Field Testing (RFT) Probes

The Remote Field Testing (RFT) technique is a variation of the eddy current send/receive probe technique. The exciter coils are separated from the receiver coils by a distance equivalent to two or three times the tube OD. The receiver coils sense the flux lines that cross the tube wall twice. Remote field has an equal sensitivity to ID and OD indications, while the phase shift is directly proportional to wall loss. The remote field testing technique is used for the inspection of ferromagnetic tubing; such as carbon steel and ferritic stainless, as well as for the detection and sizing of wall thinning resulting from corrosion, erosion, wear, pitting, and baffle cuts.



Frequency Selection for all RFT Probes

- 20 Hz to 200 Hz used for carbon steel thicker than 6mm
- 100 Hz to 1000 Hz used for carbon steel applications like SA214 or SA179 (most popular)
- 1 kHz to 10 kHz used for thin or lower permeability carbon steel like A-556
- 5 kHz to 30 kHz used for ferromagnetic stainless steel like SS439 (A-268) or SEA-Cure

Tube diameter (mm)	Tube OD diameter (inches)	Recommended Rigid probe clearance (overall)	Recommended Flexible probe clearance (overall)
12.7	1/2"	1.5mm(0.060")	
15.9	5/8"	1.5mm(0.060")	
19.05	3/4"	2.0mm(0.075")	
25.4	1	2.0mm(0.075")	
31.75	1.25	2.5mm(0.100")	5.0mm(0.200") U-bend
38.1	1.5	3.0mm(0.125")	5.0mm(0.200") U-bend
44.45	1.75	4.0mm(0.150")	6.35mm(0.250") Boilers
50.8	2	4.0mm(0.150")	7.6mm(0.300") Boilers
63.5	2.5	4.0mm(0.150")	7.6mm(0.300") Boilers
76.2	3	4.4mm(0.175")	8.26mm(0.325") Boilers
88.9	3.5	4.4mm(0.175")	8.26mm(0.325") Boilers
101.6	4	4.4mm(0.175")	8.26mm(0.325") Boilers

RFTLS Remote Field Testing Low Voltage Single Exciter



Standard Features

- Absolute and differential signal
- Single Exciter
- Includes a 30-dB preamplifier
- Wear resistant design

Probe Diameter 1mm Increments	Poly Length	Push Poly Black Polypropylene	Frequencies	Connector
0.320" to 3.000" (8 mm to 76mm)	65' (20m) 98' (30m)	Poly size Probe diam. 5/16" (8-10mm) 21/64" (11-12mm) 3/8" (13-25mm) 1/2" (26-76mm)	20-200Hz 100-1000Hz 1-10kHz 5-30kHz	19 Pin Amphenol
Custom options are available for all items				

Supporting Instruments and Software

MIZ-200 (UltraVision ET is the recommended software when using RFT probes with a MIZ-200)

MIZ-28 with must have adaptor 043A800-00 ZEC-ADP-MIZ-28-LV-RFT (allows for exciter coils to be individually excited)

RFTLD Remote Field Testing Low Voltage Dual Exciter

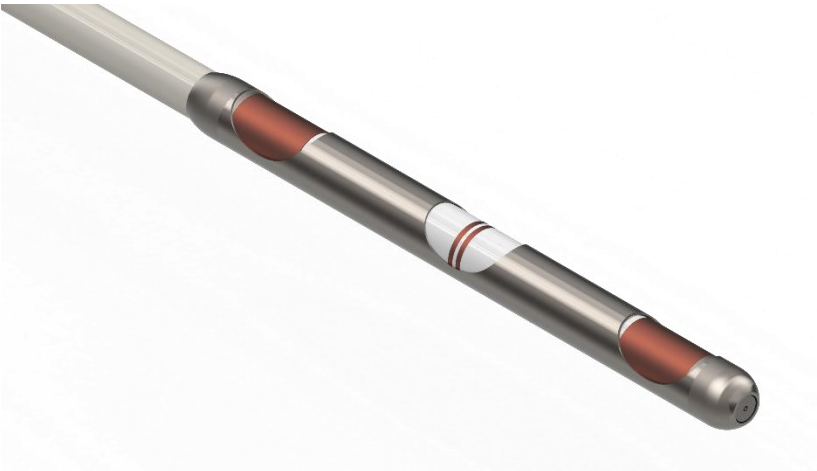

Standard Features

- Absolute and differential signal
- Single or dual driver operation selectable from the software interface (Adapter required for MIZ-28)
- Includes a 30-dB preamplifier
- Better detection of signal at tube support plate than single exciter
- Wear resistant design

Standard Options

Probe Diameter 1mm Increments	Poly Length	Push Poly Black Polypropylene	Frequencies	Connector
0.320" to 3.000" (8 mm to 76mm)	65' (20m) 98' (30m)	5/16" (8-10mm)	20-200Hz	19 Pin Amphenol
		21/64" (11-12mm)	100-1000Hz	
		3/8" (13-25mm)	1-10kHz	
		1/2" (26-76mm)	5-30kHz	
Custom options are available for all items				

Supporting Instruments and Software

MIZ-200 (UltraVision ET is the recommended software when using RFT probes with a MIZ-200)

MIZ-28 with must have adaptor 043A800-00 ZEC-ADP-MIZ-28-LV-RFT (allows for exciter coils to be individually excited)

RFTLSF Remote Field Probe Flexible Boiler, Low Voltage

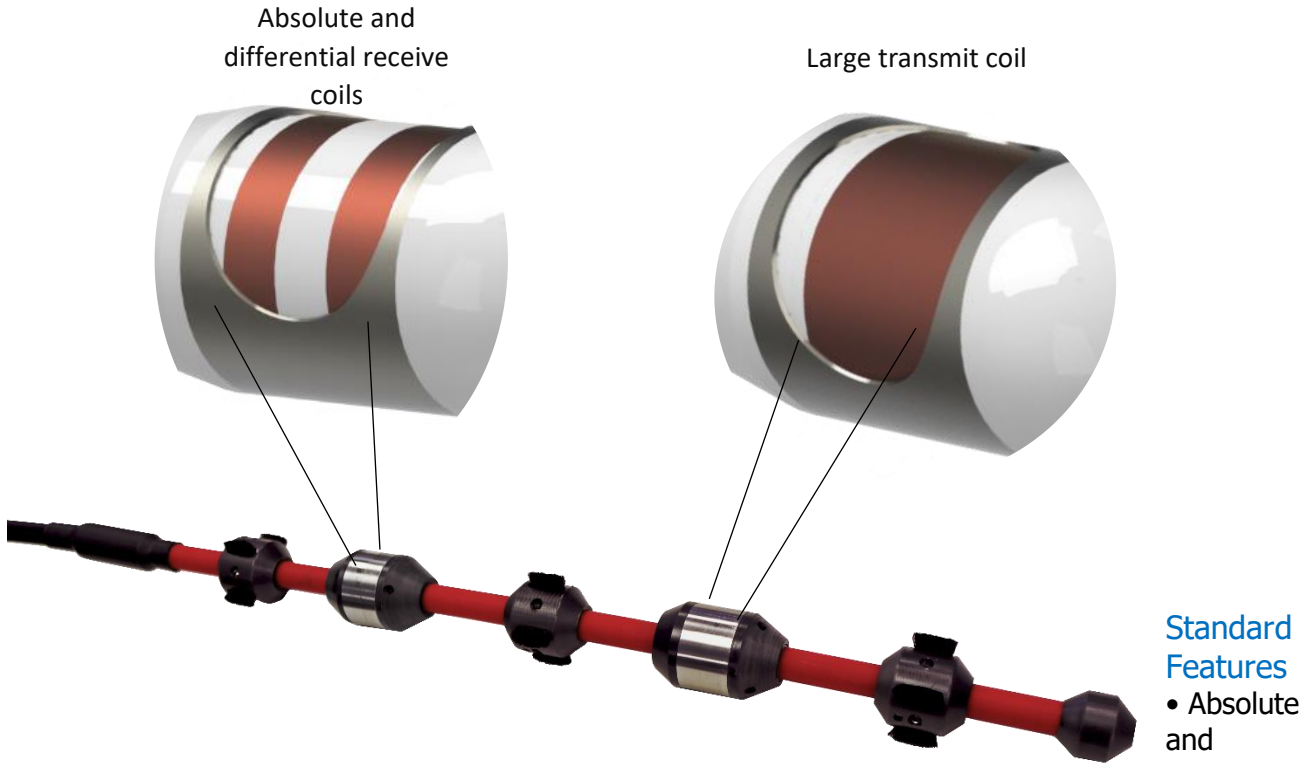

- Stainless steel sheathed coils
- Single operation
- Includes a 30-dB preamplifier
- Wear resistant design

Probe Diameter 1mm Increments	Poly Length	Push Poly Black Polypropylene	Frequencies	Connector
1.260" to 3.000" (32mm to 76mm)	65' (20m) 98' (30m)	½" (32-76mm)	20-200Hz 100-1000Hz 1-10kHz 5-30kHz	19 Pin Amphenol
Custom options are available for all items				

Supporting Instruments and Software

MIZ-200 (UltraVision ET is the recommended software when using RFT probes with a MIZ-200)

MIZ-28 with must have adaptor 043A800-00 ZEC-ADP-MIZ-28-LV-RFT (allows for exciter coils to be individually excited)

Calibration Standards

Zetec manufactures and stocks a wide variety of standards. We also manufacture standards to customer-supplied specifications.

All tubing standards are supplied with a drawing, showing as-built dimensions, material type, serial number, date of manufacture, and purchase order number. As built drawings of tube standards also record test frequency (ZQA 4.1 curve) and ET phase angles. All tubing standards fabricated from Zetec-supplied materials include material chemical certification. Plate and block standards are supplied uncertified. Zetec retains a copy of the as-built drawing at our facility as a permanent record.

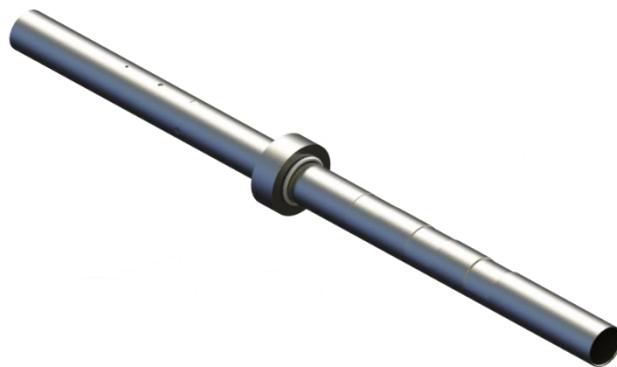

ASME Standard with Tube Support Ring

Effective 1 January 2007, all requests for Zetec supply of standards in support of Steam Generator inspections will require “Customer Supplied Material” and will also require a Zetec receipt inspection in accordance with QAS-3013-PR-S. Contact Zetec Customer Service for more details about supplying your material for manufacturing.

Ordering Calibration Standards

The following information should be provided when ordering a standard:

1. Probe being used with the standard
2. Serial number of existing similar standard or concept drawing
3. Material of the standard
4. Tubing OD and wall thickness of the standard, or thickness of a flat plate standard
5. Will customer supply the material?
6. Material type for tube supports (if required)
7. For tubing standards is it
 - a. Inline
 - b. Guide tube
 - c. Handheld
8. Specific flaw information
 - a. Type of flaw
 - b. Orientation, dimensions and tolerance of flaw

MIZ-21C Probes and Accessories

Recommended Probe Capability Matrix for Surfaces, Welds, Holes

Flaw Type / Probe Type (Model)	Surf-X (XPSC)	Pencil (DPT/DPTU)	Blade (BLD)	Slide (SLD)	Ring (RNG)	Spot (SPT)	Weld (WSPPP, WSPXP)	Conductivity (T/D)	Bond Tester (1) (SP3L)	Rotating (AFRTP, ARTP,	Manual Bolt Hole / Countersink
Crack detection and characterization	✓	✓	✓	✓	✓	✓	✓	—	—	✓	✓
Corrosion	✓	✓	✓	✓	✓	✓	✓	—	—	✓	✓
Pitting	✓	✓	✓	✓	✓	✓	✓	—	—	✓	✓
Ferrous Weld	✓	—	—	—	—	—	✓	—	—	—	—
Nonferrous Weld	✓	○	○	—	—	—	✓	—	—	—	—
C-Scan / 3D Resolution	✓	—	—	—	—	—	—	—	—	✓	✓
Countersinks	—	—	—	—	—	—	—	—	—	✓	✓
Paint Thickness	✓	○	○	—	—	○	○	✓	—	—	—
Conductivity	—	—	—	—	—	—	—	✓	—	—	—

(1) Bond tester probes currently supported only for MIZ-21SR already in the field.

- ✓ Best method for speed and flaw characterization
- ✓ The test method has proven results for the specific application
- The test results obtained from the test method can be interpreted reasonably
- Test method is not suitable or non-reliable in terms of repeatability

Probe Connector Pictures



Microdot



Triax



3 Pin

4 pin Amphenol



4 Pin LEMO



4 Pin Fischer

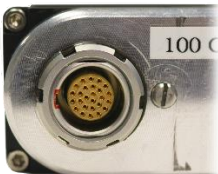

26 pin surface array

Rotating scanner probe connectors



4 Pin Step LEMO



4 Pin Fischer

Rotating scanner to MIZ-21C connectors

MIZ-21C 18Pin to Zetec 18Pin PN 111A810-00	MIZ-21C 18Pin to GE 12Pin PN 111A802-00	MIZ-21C 18Pin to Olympus 16Pin PN 111A803-00

MIZ-21C Instrument Connectors



26 pin surface array

18Pin for Handheld and rotating scanners

Probe Handles / Cables for MIZ-21C Array Surf-X Probe

Part Number	MIZ-21C Array connector	Cable Length	Probe Head / Scanner Connector
111A801-00	26-PIN	6ft (1.8m)	26-PIN_SURF-X_ARRAY_PROBES

Probe Handles / Cables for MIZ-21C for Probe Heads

Part Number	MIZ-21C connector	Handle Length	Cable Length	Probe Head Connector
111A804-00	18-PIN	No Handle	6ft (1.8m)	MICRODOT
111A805-00	18-PIN	No Handle	6ft (1.8m)	TRIAx
111A806-00	18-PIN	2.5in (63mm)	6ft (1.8m)	3-PIN
111A807-00	18-PIN	No Handle	1ft (0.9m)	4-PIN FISCHER
111A814-00	18-PIN	No Handle	6ft (1.8m)	4-PIN FISCHER
111A815-00	18-PIN	No Handle	1ft (1.8m)	BNC
111A816-00	18-PIN	No Handle	1ft (0.9m)	4-PIN Amphenol
111A817-00	18-PIN	No Handle	6ft (1.8m)	5-Pin Cannon
111A820-00	18-PIN	No Handle	6ft (1.8m)	4-PIN Female LEMO (GE Probes)
111A822-00	18-PIN	No Handle	6ft (1.8m)	4 PIN MICROTECH

Probe Cables for MIZ-21C for Rotating Scanners

Part Number	MIZ-21C connector	Cable Length	MIZ-21C to Scanner Connector
111A802-00	18-PIN	6ft (1.8m)	12-PIN GE SCANNER (MiniDrive)
111A803-00	18-PIN	6ft (1.8m)	16-PIN OLYMPUS SCANNER (MiniMite); 16-PIN OLYMPUS (SpitFire 2000); RA 2000
111A810-00	18-PIN	6ft (1.8m)	18-PIN ZETEC SCANNER
111A818-00	18-PIN	6ft (1.8m)	8-PIN LEMO For use with 2000-02-01 or 10013082 (Rotating Scanner); 2000-02-05 or (Indexing Scanner)
111A819-00	18-PIN	6ft (1.8m)	12-PIN LEMO For use with 2100-02-10 or 10015217 (ZS-4)
111A821-00 Not supported	18-PIN	6ft (1.8m)	16-PIN UniWest ECS-1; UniWest JF-15 (Keyed different than 111A803-00 and 24V)
111A823-00	18-PIN	6ft (1.8m)	8 PIN Rohmann

Probe Handles / Cables for Other Zetec Instruments

Instrument	Cable Part Number	Handle Length	Cable Length	Instrument connector	Probe Head Connector
MIZ-21A/B/SR	10025251	2in (51mm)	6ft (1.8m)	4 pin Fischer	3 PIN
MIZ-20/22/40/50	10026386	2in (51mm)	6ft (1.8m)	4 pin Amphenol	3 PIN
MIZ-21 A/B	999A800-00	No Handle	6ft (1.8m)	4 pin Fischer	MICRODOT
MIZ-20/22/40/50	999A801-00	No Handle	6ft (1.8m)	4 pin Amphenol	MICRODOT
MIZ-21 A/B/SR	999A802-00	No Handle	1ft (1.8m)	4 pin Fischer	BNC
MIZ-21 A/B/SR		No Handle			(2) BNC
MIZ-20/22/40/50	999A803-00	No Handle	1ft (1.8m)	4 pin Amphenol	BNC
MIZ-21 A/B/SR	10003552-1	No Handle	6ft (1.8m)	4 pin Fischer	TRIAx
MIZ-20/22/40/50	999A805-00	No Handle	6ft (1.8m)	4 pin Amphenol	TRIAx
MIZ-27	10007562-1	No Handle		12P Bendix	TRIAx
MIZ-21 A/B/SR	999A806-00 10008165-1?	N/A	6ft (1.8m)	4 pin Fischer	4 PIN Fischer
MIZ-20/22/40/50	999A807-00	N/A	6ft (1.8m)	4 pin Amphenol	4 PIN Fischer
MIZ-21 A/B/SR	999A810-00	N/A	6ft (1.8m)	4 pin Fischer	5-Pin Cannon
MIZ-21 A/B/SR	999A811-00	N/A	6ft (1.8m)	4 pin Fischer	4 PIN LEMO (GE Probes)
MIZ-20/22/40/50	999A812-00	N/A	6ft (1.8m)	4 pin Amphenol	4 PIN MICROTECH

Aerospace Probe Starter Kit



Part Number: PROBEKIT-001

Part Number	Full Description
BLD-001	BLD = Detachable Blade Probe Straight (for Blade Probes, Probe Diameter is the blade thickness); Item Diameter: 0.060in (1.5mm); Coil: 250= 50-500 kHz; Length: 6in (152mm); Connector: 1 Pin Female Triaxial Connector Handheld
SLD-001	SLD = Detachable Sliding Probe with Reflection (Driver Pick-up Coils); Item Diameter: 0.500in (12.7mm); Coil: 0049= .3-10 kHz; Length: No cable; Connector: 1 Pin Female Triaxial Connector Handheld; MIZiD: No; Coil Diameters 0.500" (12.7mm)
SPT-001	SPT = Detachable Spot Probe with Reflection (Driver Pick-up Coils); Item Diameter: 0.400in (10.2mm); Coil: 049= 1-100 kHz; Length: No cable; Connector: 1 Pin Female Triaxial Connector Handheld; MIZiD: No; Coil Diameters 0.400" (10.2mm)
RNG-001	RNG = Detachable Ring Probe with Reflection (Driver Pick-up Coils); Item Diameter: 0.670in (17mm); Coil: 047= .1-100 kHz; Length: No cable; Connector: 1 Pin Female Triaxial Connector Handheld; MIZiD: No; Coil Diameters: 0.670" (25.5mm) Internal Diameter, 1.100" (17.0mm) outer diameter
DPT90-002	DTP90 = Detachable Pencil Tip Probe 90 Degree Shielded; Item Diameter: 0.125in (3.2mm); Coil: 250= 50-500 kHz; Length: 5in (127mm); Connector: 1 Pin Female Triaxial Connector Handheld; MIZiD: No; Drop is 0.5 inch (12.7mm)
DPT45-002	DTP45 = Detachable Pencil Tip Probe 45 Degree Shielded; Item Diameter: 0.125in (3mm); Coil: 250= 50-500 kHz; Length: 5in (127mm); Connector: 1 Pin Female Triaxial Connector Handheld; MIZiD: No; Drop is 0.5 inch (12.7mm)
DPT-002	DTP = Detachable Pencil Tip Probe Straight Shielded; Item Diameter: 0.125in (3mm); Coil: 250= 50-500 kHz; Length: 5in (127mm); Connector: 1 Pin Female Triaxial Connector Handheld
111A805-00	6ft MIZ-21C to Triax Probe Connector

Eddy Current Surface Array Probes

Eddy current surface array probes allow for fast inspection of surfaces with varying materials and geometries utilizing the eddy current technique. Surface preparation is not necessary as compared to penetrant inspection methods. Additionally, there are no chemical usage or environmental concerns as compared to Magnetic Particle or penetrant inspection methods.

XPSC Surf-X™ Non-Ferrous Array Probe

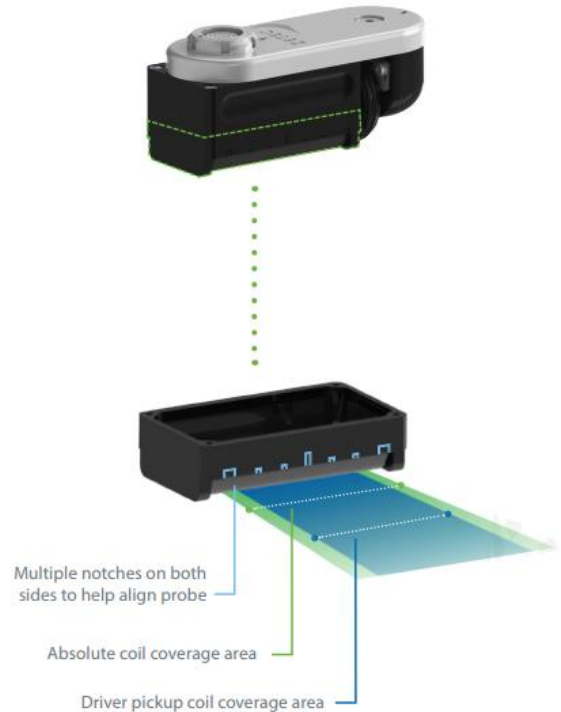

Applications / Standard Features

- Quick and accurate inspections
- Patented X-Probe Coil Technology
- Rotatable Encoder comes standard
- Specially designed long wear surface
- Field replaceable components

Coverage width	Coils	Cable Length	Materials	Penetration Depth	Weld Crown	Part Number
Absolute 1.7" (43.2mm)	2x16 (32)	6ft (1.8m)	Non-Ferrous	Up to 0.25" (6.3mm)	Up to 0.25" (6.3mm)	XPSC-001
Driver Pickup 1.5" (38.1mm)			Ferrous (surface flaws)			
Other options available upon request						

Supporting Instruments and Accessories

- MIZ-21C Array: The Most Advanced Handheld with Surface Array Capability (PN 111A903-00)
- Cable adapter: MIZ®-21C to array probe 6ft (1.8m) (PN 111A801-00)
- Replaceable wear surface assembly (PN 126A200-00)
- Replaceable encoder wheel (PN 126A300-00)
- Factory replaceable coil set assembly (PN 126A602-00)

Pencil Probes

DPT Detachable Tip Pencil Probe Straight Shielded

DPTU Detachable Tip Pencil Probe Straight Unshielded



DPT45 Detachable Tip Pencil Probe 45 degree Shielded

DPT45U Detachable Tip Pencil Probe 45 degree Unshielded

Drop
0.5"
(12.7m



DPT90 Detachable Tip Pencil Probe 90 degree Shielded

DPT90U Detachable Tip Pencil Probe 90 degree Unshielded

Drop
0.5"
(12.7m



Applications / Standard Features

- Designed for general crack detection.
- **Shielded
- Drop is 0.5" (12.7mm). Other drops upon request.

Probe Shaft Diameter	Probe Coil Outside Diameter	Connector to tip length options	Frequencies Options	Connector Options
0.072" (1.8mm)	0.062" (1.6mm)	4" (mm)	*50-500kHz	Microdot *Triax
0.093" (2.4mm)		*5" (mm)	500kHz-1MHz	
*0.125" (3.2mm)		6" (mm)	**1-3MHz (0.125 shaft only)	
* most common		Custom options are available for all items		
** 1-3MHz uses unshielded models DPTU, DPT45U and DPT90U to provide a better response				

Pencil probes can detect indications down to approximately ½ the coils diameter.

Supporting Instruments

MIZ-21C (all Versions)

Cable adapters: Match connector to applicable adapter. [Quick Link](#)

DPTTAP Detachable Tip Pencil Probe Tapered Shielded

Applications / Standard Features

- Designed for general crack detection.

Probe Shaft Diameter	Probe Coil Outside Diameter	Connector to tip length options	Frequencies Options	Connector Options
N/A	0.062" (1.6mm)	4" (mm)	*50-500kHz 500kHz-1MHz **1-3MHz (0.125 shaft only)	Microdot Triax
* most common Custom options are available for all items				
** 1-3MHz uses unshielded models DPTU, DPT45U and DPT90U to provide a better response				

Pencil probes can detect indications down to approximately ½ the coils diameter.

Pencil Probe Tip Covers

Protect the materials you are inspecting and the probe coils.

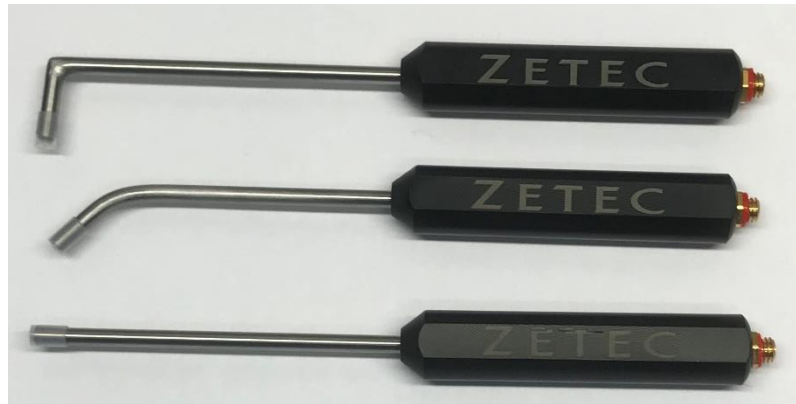

Part Numbers

Part Number	Description	Probe Shaft Diameter	Wear surface thickness
*70000779-3	Pencil probe tip protective cover Diameter 0.125" (3.2mm)	0.072" (1.8mm)	0.008" to 0.10" (0.203mm to 0.254mm)
70000779-1	Pencil probe tip protective cover Diameter 0.072" (1.8mm)	0.093" (2.4mm)	
70000779-2	Pencil probe tip protective cover Diameter 0.093" (2.4mm)	*0.125" (3.2mm)	
* most common. Minimum order quantity of 10			

Blade Probes

BLD Detachable Tip Pencil Probe Straight Shielded



BLD45 Detachable Tip Blade Probe 45 degree Shielded

BLD60 Detachable Tip Blade Probe 60 degree Shielded

BLD90 Detachable Tip Blade Probe 90 degree Shielded

Applications / Standard Features

- Designed for surface detection in narrow slots or gaps. Both sides of the probe will detect defects.
- **Shielded
- Drop is 0.5" (12.7mm) for any angled probes. Other drops upon request.

Shaft Thickness (Width of the shaft)	Connector to tip length Options	Frequencies Options	Connector Options
0.030" (0.8mm) 0.045" (1.1mm) *0.060" (1.5mm) 0.090" (2.3mm)	6" (mm)	*50-500kHz **1-3MHz (0.125 coil only)	Triax
* most common Custom options are available for all items ** 1-2MHz uses unshielded models BLDU, BLD45U, BLD60U, BLD90U to provide a better response Note: Microdot connectors are not used because Triax provides a better response			

Supporting Instruments

MIZ-21C (all Versions)

Cable adapters: Match connector to applicable adapter. [Quick Link](#)

Slide Probes

SLD Detachable Tip Sliding Probe with Reflection (Reflection / Driver Pick-up Coils)

For detection of near side to far side indications near fasteners. For faster inspections ask about Zetec's Surf-X probes.

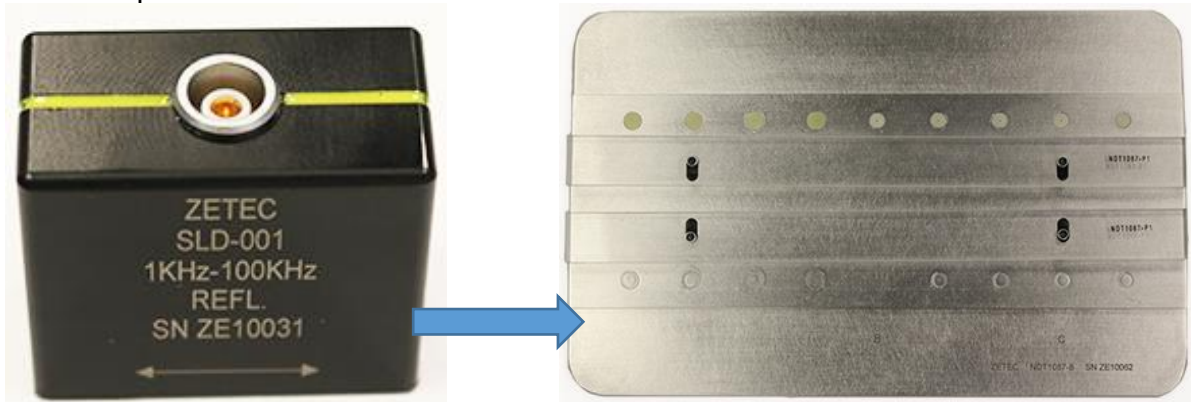

Probe Coil outside diameter	Frequencies Options	Connector Options
Customer recommended coil diameter or coverage width	Provide Frequency	Triax
Custom options are available for all items		

Coil diameter should be sized to find flaws of interest.

Applications / Standard Features

- Inspecting rows of flush fasteners

Example of commonly used probe

Part Number	Description	Probe Coil Outside Diameter	Coil operation	Frequencies	Connector
SLD-001	ZHHD-SLD-E00.500-0049-00Z0000	0.500" (12.7mm)	Reflection (Driver Pick-up)	0.3-10 kHz	Triax

Supporting Instruments

MIZ-21C (all Versions)

Cable adapters: Match connector to applicable adapter. [Quick Link](#)

Ring Probes

RNG Detachable Tip Ring Probe with Reflection (Driver Pick-up Coils)

For examination the body surface of protruding fasteners



Probe Coil inside diameter	Frequencies Options	Connector Options
Customer recommended coil inside diameter or coverage width	Provide Frequency	Triax
Custom options are available for all items		

Applications / Standard Features

- Inspecting protruding fasteners for surface and subsurface cracks in the material or multilayer structure

Example of commonly used probe

Part Number	Description	Probe Coil Inside / Outside Diameter	Coil operation	Frequencies	Connector
RNG-001	ZHHD-RNG-E00.670-047-00Z0000	0.670" (17.0mm) / 1.100" (27.9mm)	Reflection (Driver Pick-up)	0.1-100 kHz	Triax

Supporting Instruments

MIZ-21C (all Versions)

Cable adapters: Match connector to applicable adapter. [Quick Link](#)

Spot Probes

SPT Detachable Tip Spot Probe with Reflection (Driver Pick-up Coils)

SPTU Detachable Tip Spot Probe with Reflection (Driver Pick-up Coils) Unshielded

Probe Coil outside diameter	Frequencies Options	Connector Options
Customer recommended coil diameter or coverage width	Provide Frequency	Triax
Custom options are available for all items		

Applications / Standard Features

- Inspecting deep and far side flaws

Example of commonly used probe

Part Number	Description	Probe Coil Outside Diameter	Coil operation	Frequencies	Connector
SPT-001	ZHHD-SPT-E00.400-049-00Z0000	0.400" (10.2mm)	Reflection (Driver Pick-up)	1-100 kHz	Triax
SPTU-001	ZHHD-SPTU-E00.250-#-00Z0000	0.250" (6.4mm)	Reflection (Driver Pick-up)	100-500 kHz	Triax

Minimum outside coil diameter is 0.250"

Supporting Instruments

MIZ-21C (all Versions)

Cable adapters: Match connector to applicable adapter. [Quick Link](#)

Weld Probes

WSPPP Weld Scan Probe with Differential Plus Point Coil



10025177

Applications / Standard Features

- Inspection of Raised Weld Beads
- Operating in Differential Mode

WSPXP Weld Scan Probe with Driver Pickup Cross Point Coil



10025328

Applications / Standard Features

- Inspection of Flush Ground Welds (better for flat surfaces)
- Operating in Driver-Pickup Mode

Part Numbers	Coil Diameter Options	Probe Tip Diameter Options	Handle Length	Frequencies	Connector
WSPPP-001	0.245" (6.22mm)	0.312" (7.92mm)	5.0" (127mm)	30-300kHz +point	Triax
10025177			NA	30-300kHz +point	3 Pin
WSPXP-001			5.0" (127mm)	30-300kHz Xpoint	Triax
10025328			NA	30-300kHz Xpoint	3 Pin
Custom options are available for all items					

Supporting Instruments

MIZ-21C (all Versions)

Cable adapters: Match connector to applicable adapter. [Quick Link](#)

T/D Conductivity Probe



Example of commonly used probe

Part Numbers	Description	Cable Length	Adapter MIZ-21C	Frequencies	Connector
10025934	ZHHP-T/D-375-SP-6-4PA	6ft	111A816-00	60kHz	4 pin Amphenol
10025171	ZHHD-T/D-375-SP-6-4PF	6ft	111A807-00	60kHz	4 pin Fischer

Applications / Standard Features

- Determining conductivity of metals and thickness of coatings

Supporting Instruments

MIZ-21C (all Versions)

Cable adapters: Match connector to applicable adapter. [Quick Link](#)

Probes for Rotating Scanners

RTP Rotating Probe for Mini Scanners, Reflection D coils (Driver Pick-up)



Hole Size	Frequencies Options	Connector Options
Customer recommended hole diameter range	Provide Frequency Range	4 Pin Fischer (Zetec / GE Scanners) 4 Pin Step LEMO (Most Olympus Scanners)
Custom options are available for all items		

Applications / Standard Features

- Inspecting flaws on the ID of a fastener hole
- Reflection (Driver Pick-up D coils)

Commonly used probes

Part Number	Hole Diameter Range	Working Length	Connector type	Frequency Range
RTP-013	0.125-0.156in (3.18-3.96mm)	1.75" (44mm)	4 Pin Fischer	100-2000 kHz
RTP-014	0.156-0.187in (3.96-4.75mm)	1.75" (44mm)	4 Pin Fischer	100-2000 kHz
RTP-001	0.187-0.218in (4.75-5.54mm)	1.75" (44mm)	4 Pin Fischer	100-2000 kHz
RTP-003	0.218-0.250in (5.54-6.35mm)	2.0" (51mm)	4 Pin Fischer	100-2000 kHz
RTP-004	0.250-0.281in (6.35-7.14mm)	2.0" (51mm)	4 Pin Fischer	100-2000 kHz
RTP-005	0.281-0.312in (7.14-7.92mm)	2.0" (51mm)	4 Pin Fischer	100-2000 kHz
RTP-006	0.312-0.375in (7.92-9.53mm)	2.0" (51mm)	4 Pin Fischer	100-2000 kHz
RTP-002	0.375-0.437in (9.53-11.1mm)	2.0" (51mm)	4 Pin Fischer	100-2000 kHz
RTP-007	0.437-0.500in (11.1-12.7mm)	2.0" (51mm)	4 Pin Fischer	100-2000 kHz
RTP-008	0.500-0.562in (12.7-14.27mm)	2.0" (51mm)	4 Pin Fischer	100-2000 kHz
RTP-009	0.562-0.625in (14.27-15.88mm)	2.0" (51mm)	4 Pin Fischer	100-2000 kHz
RTP-010	0.625-0.687in (15.88-17.45mm)	2.0" (51mm)	4 Pin Fischer	100-2000 kHz
RTP-011	0.687-0.750in (17.45-19.05mm)	2.0" (51mm)	4 Pin Fischer	100-2000 kHz
RTP-012	0.750-0.812in (19.05-20.62mm)	2.0" (51mm)	4 Pin Fischer	100-2000 kHz

Supporting Instruments

MIZ-21C (PN: 111A902-00) and MIZ21C Array (PN: 111A903-00)

Rotating Scanners: Zetec (PN: 169A901-00), GE or Olympus

Scanner Cable Adapters: Match scanner connector to applicable adapter. [Quick Link](#)

ARTP Adjustable Rotating Probe for Mini Scanners, Reflection D coils (Driver Pick-up)



Hole Size	Frequencies Options	Connector Options
Customer recommended hole diameter range	Provide Frequency Range	4 Pin Fischer (Zetec / GE Scanners) 4 Pin Step LEMO (Most Olympus Scanners)
Custom options are available for all items		

Applications / Standard Features

- Inspecting flaws on the ID of a fastener hole. Adjustable probe tips coverage a large range of diameters than non-adjustable probe tips.
- Reflection (Driver Pick-up D coils)

Commonly used probes

Part Number	Hole Diameter Range	Working Length	Connector type	Frequency Range
ARTP-002	0.125-0.156in (3.18-3.96mm)	1.75" (44mm)	4 Pin Fischer	100-2000 kHz
ARTP-003	0.156-0.187in (3.96-4.75mm)	1.75" (44mm)	4 Pin Fischer	100-2000 kHz
ARTP-001	0.187-0.218in (4.75-5.54mm)	1.75" (44mm)	4 Pin Fischer	100-2000 kHz
ARTP-004	0.218-0.250in (5.54-6.35mm)	2.0" (51mm)	4 Pin Fischer	100-2000 kHz
ARTP-005	0.250-0.281in (6.35-7.14mm)	2.0" (51mm)	4 Pin Fischer	100-2000 kHz
ARTP-006	0.281-0.312in (7.14-7.92mm)	2.0" (51mm)	4 Pin Fischer	100-2000 kHz
ARTP-007	0.312-0.375in (7.92-9.53mm)	2.0" (51mm)	4 Pin Fischer	100-2000 kHz
ARTP-008	0.375-0.437in (9.53-11.1mm)	2.0" (51mm)	4 Pin Fischer	100-2000 kHz
ARTP-009	0.437-0.500in (11.1-12.7mm)	2.0" (51mm)	4 Pin Fischer	100-2000 kHz
ARTP-010	0.500-0.562in (12.7-14.27mm)	2.0" (51mm)	4 Pin Fischer	100-2000 kHz
ARTP-011	0.562-0.625in (14.27-15.88mm)	2.0" (51mm)	4 Pin Fischer	100-2000 kHz
ARTP-012	0.625-0.687in (15.88-17.45mm)	2.0" (51mm)	4 Pin Fischer	100-2000 kHz

Supporting Instruments

MIZ-21C (PN: 111A902-00) and MIZ21C Array (PN: 111A903-00)

Rotating Scanners: Zetec (PN: 169A901-00), GE or Olympus

Scanner Cable Adapters: Match scanner connector to applicable adapter. [Quick Link](#)

AFRTP Adjustable Flexible Rotating Probe for Mini Scanners, Reflection D coils (Driver Pick-up)



Hole Size	Frequencies Options	Connector Options
Customer recommended hole diameter range	Provide Frequency Range	4 Pin Fischer (Zetec / GE Scanners) 4 Pin Step LEMO (Most Olympus Scanners)
Custom options are available for all items		

Applications / Standard Features

- Inspecting flaws on the ID of a fastener hole where a slight bend occurs for entering the hole
- Reflection (Driver Pick-up D coils)

Commonly used probes

Part Number	Hole Diameter Range	Working Length	Connector type	Frequency Range
AFRTP-001	0.187-0.250in (4.75-6.35mm)	6.0" (152mm)	4 Pin Fischer	100-2000 kHz
AFRTP-002	0.250-0.312in (6.35-7.92mm)	6.0" (152mm)	4 Pin Fischer	100-2000 kHz
AFRTP-003	0.312-0.375in (7.92-9.53mm)	6.0" (152mm)	4 Pin Fischer	100-2000 kHz
AFRTP-004	0.375-0.437in (9.53-11.1mm)	6.0" (152mm)	4 Pin Fischer	100-2000 kHz
AFRTP-005	0.437-0.500in (11.1-12.7mm)	6.0" (152mm)	4 Pin Fischer	100-2000 kHz
AFRTP-006	0.500-0.625in (12.7-15.88mm)	6.0" (152mm)	4 Pin Fischer	100-2000 kHz
AFRTP-007	0.625-0.687in (15.88-17.45mm)	6.0" (152mm)	4 Pin Fischer	100-2000 kHz
AFRTP-008	0.687-0.750in (17.45-19.05mm)	6.0" (152mm)	4 Pin Fischer	100-2000 kHz
AFRTP-009	0.750-0.875in (19.05-22.23mm)	6.0" (152mm)	4 Pin Fischer	100-2000 kHz

Supporting Instruments

MIZ-21C (PN: 111A902-00) and MIZ21C Array (PN: 111A903-00)

Rotating Scanners: Zetec (PN: 169A901-00), GE or Olympus

Scanner Cable Adapters: Match scanner connector to applicable adapter. [Quick Link](#)

C RTP Counter Sink Rotating Probe for Mini Scanners, Reflection D coils (Driver Pick-up)



Hole Size	Frequencies Options	Connector Options
Customer recommended hole diameter range	Provide Frequency Range	4 Pin Fischer (Zetec / GE Scanners) 4 Pin Step LEMO (Most Olympus Scanners)
Custom options are available for all items		

Applications / Standard Features

- Inspecting counter sinks
- Standard probes are for 100 degree counter sink.
- Reflection (Driver Pick-up D coils)

Example of commonly used probe

Part Number	Hole Diameter	Countersink Angle	Connector type	Frequency Range
CRTP-003	0.156in (4mm)	100°	4 Pin Fischer	100-2000 kHz
CRTP-001	0.187in (5mm)	100°	4 Pin Fischer	100-2000 kHz
CRTP-002	0.250in (6mm)	100°	4 Pin Fischer	100-2000 kHz

Supporting Instruments

MIZ-21C (PN: 111A902-00) and MIZ21C Array (PN: 111A903-00)

Rotating Scanners: Zetec (PN: 169A901-00), GE or Olympus

Scanner Cable Adapters: Match scanner connector to applicable adapter. [Quick Link](#)

MBHP Manual Bolt Hole Probe, Absolute Coils

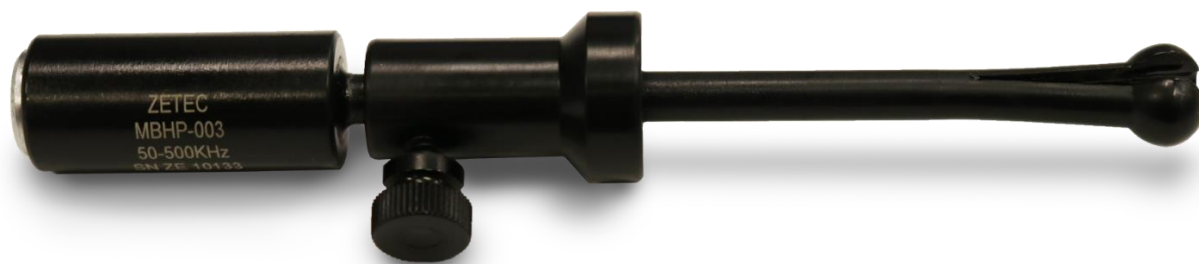

Applications / Standard Features

- Inspecting flaws on the ID of a fastener hole
- Absolute coils

Frequency Selection

50kHz-500kHz for aluminum

500kHz-1MHz for steel

1MHz-3MHz for titanium

Example of commonly used probe

Part Number	Hole Diameter Range	Working Length	Connector type	Frequency Range
MBHP-001	0.250-0.281in (6.35-7.14mm)	1.50" (38mm)	Triax	50-500 kHz
MBHP-002	0.281-0.312in (7.14-7.92mm)	1.50" (38mm)	Triax	50-500 kHz
MBHP-003	0.312-0.375in (7.92-9.53mm)	2.0" (51mm)	Triax	50-500 kHz

Supporting Instruments

MIZ-21C

Cable adapters: Match connector to applicable adapter. [Quick Link](#)

MCSP Manual Counter Sink Probe, Absolute Coils



Applications / Standard Features

- Inspecting counter sinks
- Standard probes are for 100 degree counter sink.

Frequency Selection

50kHz-500kHz for aluminum
500kHz-1MHz for steel
1MHz-3MHz for titanium

Example of commonly used probe

Part Number	Hole Diameter	Countersink Angle	Connector type	Frequency Range
MCSP-001	0.250in (6mm)	100°	Triax	50-500 kHz
MCSP-002	0.312in (8mm)	100°	Triax	50-500 kHz

Supporting Instruments

MIZ-21C

Cable adapters: Match connector to applicable adapter. [Quick Link](#)

Calibration Standards

Navy Reference Kits



Price is material dependent

PN	Sales Note
NRK-001	Navy Eddy Current Reference Standard Kit. MATERIAL: 400 STAINLESS STEEL. CONTAINS 20 FASTENER HOLES (.156-.750) WITH A TOTAL OF 71 EDM NOTCHES. Includes Test Report and Certificate of Conformance.
NRK-002	Navy Eddy Current Reference Standard Kit. MATERIAL: 17-4PH STAINLESS STEEL. CONTAINS 20 FASTENER HOLES (.156-.750) WITH A TOTAL OF 71 EDM NOTCHES. Includes Test Report and Certificate of Conformance.
NRK-003	Navy Eddy Current Reference Standard Kit. MATERIAL: 17-7PH STAINLESS STEEL. CONTAINS 20 FASTENER HOLES (.156-.750) WITH A TOTAL OF 71 EDM NOTCHES. Includes Test Report and Certificate of Conformance.
NRK-004	Navy Eddy Current Reference Standard Kit. MATERIAL: 304 STAINLESS STEEL, CONTAINING 20 FASTENER HOLES (.156-.750) WITH A TOTAL OF 71 EDM NOTCHES. Includes Test Report and Certificate of Conformance.
NRK-005	Eddy Current Reference Standard Kit. MATERIAL: 6526 Nickel Cobalt Steel, CONTAINING 20 FASTENER HOLES (.156-.750) WITH A TOTAL OF 71 EDM NOTCHES. Includes Test Report and Certificate of Conformance.
NRK-006*	Eddy Current Reference Standard Kit. MATERIAL: 7075-T6 Aluminum, CONTAINING 20 FASTENER HOLES (.156-.750) WITH A TOTAL OF 71 EDM NOTCHES. Includes Test Report and Certificate of Conformance.

* Most common

Surf-X Calibration Plate

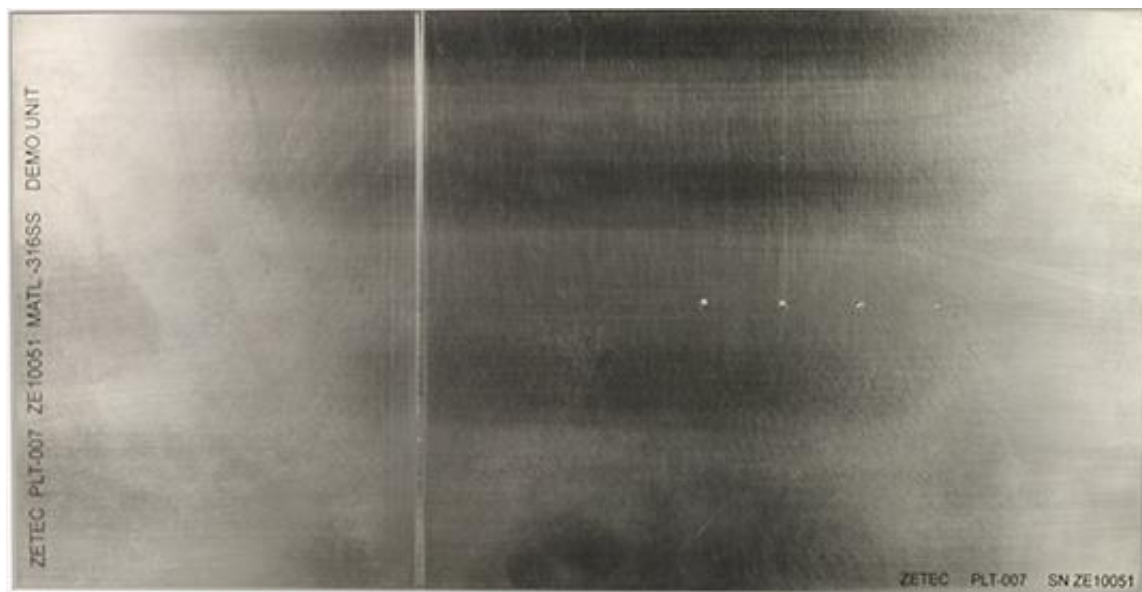

PN	Material	Plate Thickness
PLT-007	Stainless Steel 316	0.048"
PLT-009	ALUMINUM 7075-T6	0.050"

Reference Plate for Surf-X Probe

Plate Size: 11.00" long x 6.00" wide

Calibration groove (6.00" +/- 0.050" long x 0.625" +/- .0050" wide x 40% deep)

4 EDM notches at varying depths 100%, 60%, 20%, 10% (all 0.100" +/- 0.015" long and 0.005" +/- 0.002" wide)

4 Round Bottom Holes at varying depths 100% x 0.067" (TWH), 60% x 0.109", 20% x (0.188"), 10% x (0.188")

% depths have a tolerance of +/-0.003"

Boeing Reference Standard (NDT1087-X)

“-X” are for varying plate thicknesses.

- BOEING REFERENCE STANDARD 737 PT 6 53-30-00 & 777 PT6 53-30-09
- FASTENER (NAS1097D6-6DM NAS1097D5-6D, ALL ALDORIZED) (BACR15GF6D7, BACRGF5D6, ALL ALODINED).
- Includes Test Report and Certificate of Conformance.

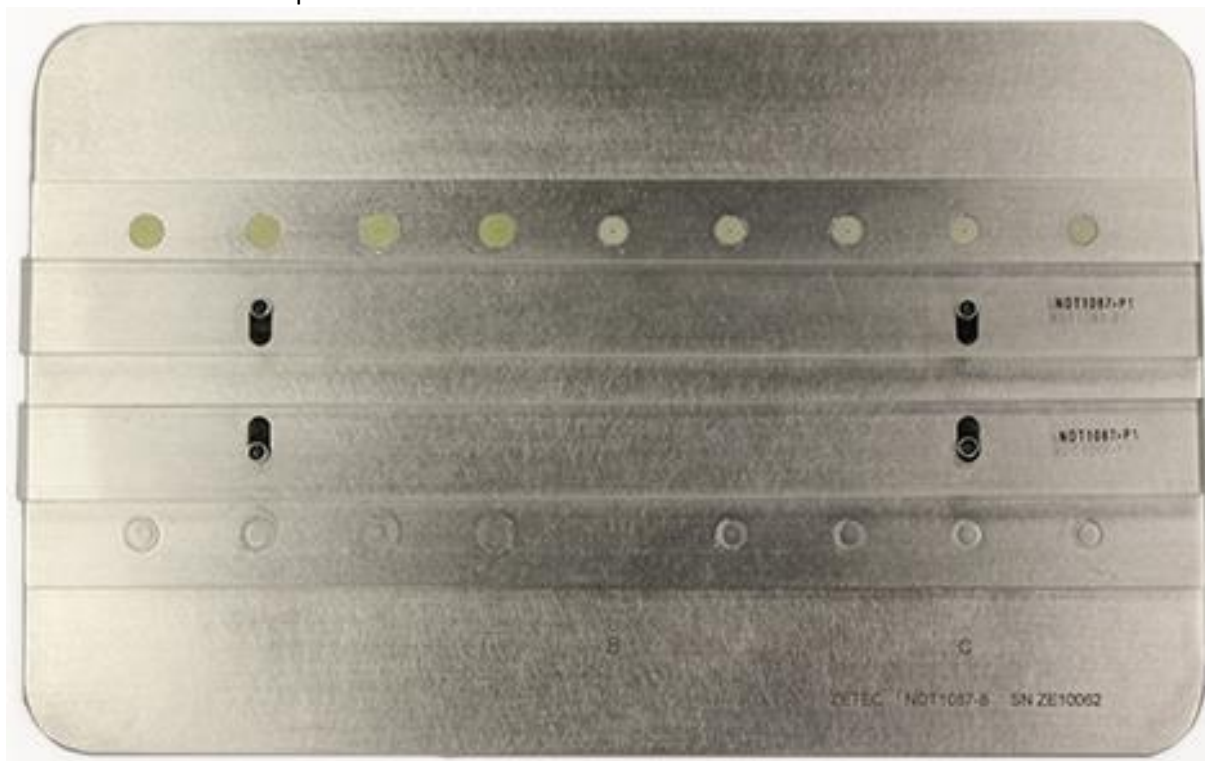

Part Numbers

Part Number	Top Plate Thickness (inch)	Bottom Plate Thickness (inch)	EDM Notch Length (inch)
NDT1087-1	0.050	0.040	0.200
NDT1087-2	0.071	0.040	0.200
NDT1087-3	0.080	0.040	0.180
NDT1087-4	0.090	0.040	0.200
NDT1087-5	0.100	0.050	0.200
NDT1087-6	0.071	0.063	0.250
NDT1087-7	0.090	0.080	0.250
NDT1087-8	0.100	0.900	0.250
NDT1087-9	0.036	0.036	

MIZ-21C Demo Reference Plate

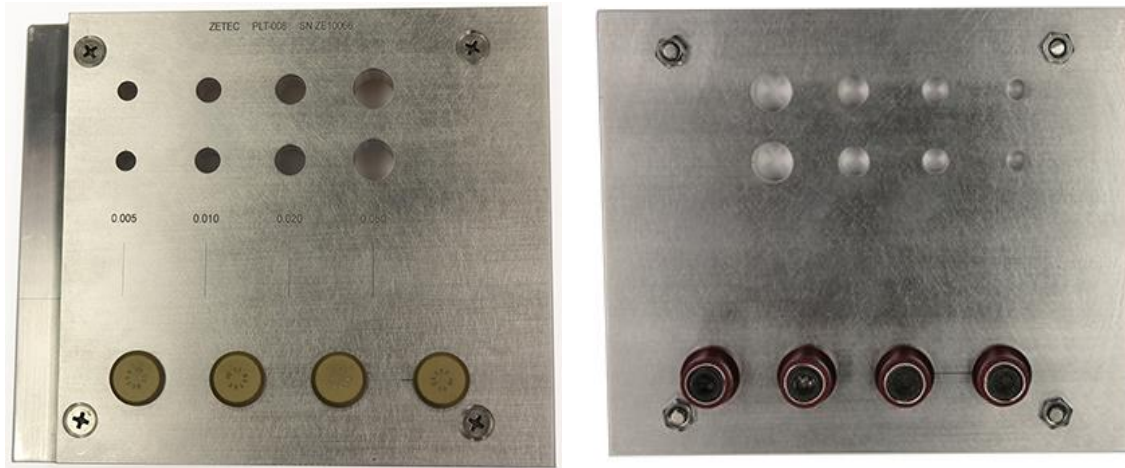

5.5" x 6.5" ALUMINUM 7075-T6 MIZ-21C Demo Reference Plate
 3/8" thick bottom plate, 3/16" thick top plate

4 EDM surface notches (pencil probes and spot probe) L = 0.650", W = 0.005", D = 0.005", 0.010", 0.020", 0.050"

8 through wall holes: 2x 0.250"; 2x 0.312"; 2x 0.375"; 2x 0.500" (rotating bolt hole probes)
 4 of the through wall holes on the top plate have (2) 0.030" deep x 0.005" wide EDM notches at a 45 degree angle on the near and far side of the top plate and 180 degrees apart.
 4 of the through wall holes on the bottom plate have (1) 100% EDM through bottom plate only 0.020" D x 0.005" W

4 through wall holes with 100 degree counter sinks (Counter sink rotating probe)
 Counter sink holes contain titanium fasteners (Ring Probes)
 1 of the counter sink holes has a 100% EDM notch L = 0.250", W = 0.010"

1 100% EDM notch on the surface of the bottom plate only between first 2 TWHs on 3rd row W = 0.010" (spot probe)

0.250" radiused edge with circumferential EDM notch 0.025" D x 0.005 W and length follows the entire contour and axial EDM notch that is 0.025" D x 0.005 W x 0.500" L
 0.250" deep x 0.005" wide EDM axial and circumferential notch (+point weld probe).

Price is material dependent

PN	Sales Note
PLT-008	Zetec MIZ-21C Demo Kit Reference Plate ALUMINUM 7075-T6

Crack Flaw Standards

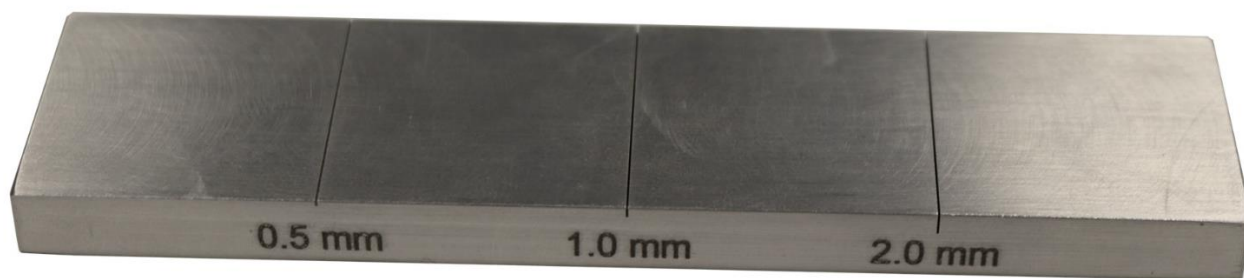

Block Size: 4.0"(101.6mm)L x 1.0"(25.4mm)D x 0.25"(6.35mm)H.

Includes 3 EDM Flaws of the following sizes:

1.) (0.5mm)D x (0.25mm)W x (25mm)L

2.) (1.0mm)D x (0.25mm)W x (25mm)L

3.) (2.0mm)D x (0.25mm)W x (25mm)L

Includes Test Report and Certificate of Conformance.

Price is material dependent

PN	Sales Note
NDT-3025CS	Eddy Current 3 Crack Surface Standard 4340 Carbon Steel
NDT-3025INC	Eddy Current 3 Crack Surface Standard 718 Inconel
NDT-3025AL	Eddy Current 3 Crack Surface Standard 7075-T6 Aluminum

* Most common

For more information, visit
www.Zetec.com
or contact us at:
customerservice@Zetec.com

ZETEC

THE INSPECTION ADVANTAGE

